



Vision

THE CITY OF BETTENDORF IS THE MOST LIVABLE COMMUNITY WITH RICH EDUCATIONAL, CULTURAL, AND RECREATIONAL OPPORTUNITIES WHERE WE ENJOY A VIBRANT RIVERFRONT AND A GROWING, COMPETITIVE BUSINESS ENVIRONMENT. WE TAKE PRIDE IN OUR GREAT COMMUNITY.

The Vision Statement for the City of Bettendorf outlines what Bettendorf wants in the future. Our preferred future is defined in value-based principles that can guide policies, decisions, and operations. The City of Bettendorf is a Premier City in which to live.

**BETTENDORF CITY COUNCIL
COMMITTEE OF THE WHOLE
COUNCIL CHAMBERS – CITY HALL**

MONDAY, APRIL 14, 2025

5:00 P.M.

The Bettendorf City Council Committee of the Whole meeting will be open to the public. Additionally, the City of Bettendorf will broadcast this public meeting online at www.bettendorf.org/YouTube

AGENDA

I. PRESENTATION

Family Resources' Coordinated Assessment Program (CAP) – Bettendorf Police Chief Keith Kimball, Nicole Cisne Durbin, CEO, Family Resources, Davenport Police Chief Jeff Bladel, and Major Shawn Roth, Scott County Sheriff's Department

II. CONSENT AGENDA ITEMS

- Resolution approving an agreement with the Iowa Department of Transportation for intelligent transportation and security system integration for the I-74 Bridge area – Lt. Andrew Champion **(Consent E)**

III. REMAINING CONSENT AGENDA ITEMS

IV. ITEMS TO APPEAR

- Public Hearing regarding the adoption of the FY2025/26 Budget and Certification of Taxes – Finance Director Jason Schadt **(Items to Appear 10 & 11)**

V. ITEMS ADDED BY MAYOR AND COUNCIL

VI. ADJOURN

IN COMPLIANCE WITH THE AMERICANS WITH DISABILITIES ACT AND OTHER APPLICABLE FEDERAL AND STATE LAWS, ALL PUBLIC HEARINGS AND MEETINGS HELD OR SPONSORED BY THE CITY OF BETTENDORF, IOWA WILL BE ACCESSIBLE TO INDIVIDUALS WITH DISABILITIES. PERSONS REQUIRING AUXILLARY AIDS AND SERVICES SHOULD CONTACT BETTENDORF CITY HALL AT (563) 344-4000 FOUR (4) HOURS PRIOR TO THE HEARING OR MEETING TO INFORM OF THEIR ANTICIPATED ATTENDANCE.

**CITY OF BETTENDORF CITY COUNCIL MEETING
COUNCIL CHAMBERS – CITY HALL**

**TUESDAY, APRIL 15, 2025
7:00 P.M.**

The Bettendorf City Council meeting will be open to the public. Additionally, the City of Bettendorf will broadcast this public meeting online at www.bettendorf.org/YouTube

AGENDA

1. ROLL CALL

2. PLEDGE OF ALLEGIANCE

3. INVOCATION

Given by Bettendorf Police Chaplain and Pastor of Hope Baptist Church, Pastor Mark Cannon

4. AWARD

Urban Forest Growth Award, Tree City USA Award presented by Bob Sartor

5. PROCLAMATION

Arbor Day, April 25, 2025, requested by Bob Sartor, Trees Are Us and Parks Advisory Board

6. PROCLAMATION

National Telecommunicator's Week, April 13 – 19, 2025 requested by Bettendorf Police Department

7. PROCLAMATION

Child Abuse Prevention Month, April 2025 requested by Bettendorf Police Department

8. PROCLAMATION

National Small Business Week, May 4-10, 2025, requested by QC Chamber of Commerce, Government Affairs

9. PUBLIC REQUESTS OF COUNCIL

The public is welcome to make a request of council on any item not already on the agenda for public hearing. Please limit your comments to two minutes. Please try not to be repetitive. Please refrain from outbursts, like clapping and yelling. Please be respectful with your comments.

10. PUBLIC HEARING

Regarding the adoption of the FY2025/26 Budget and Certification of Taxes

11. RESOLUTION

Council Member Naumann to present a resolution approving and adopting the FY2025/26 Budget and Certification of Taxes

12. PUBLIC HEARING

Regarding the FY2026 application for State Transit Assistance funds for Transit System Operations

13. RESOLUTION

Council Member Brown to present a resolution approving the FY2026 application for State Transit Assistance funds for Transit System Operations

14. PUBLIC HEARING

Regarding the 2025 Full Depth Patching Program

15. RESOLUTION

Council Member Sechser to present a resolution approving the plans, specifications, and form of contract for the 2025 Full Depth Patching Program

16. PUBLIC HEARING

Regarding the Devils Glen Road over Duck Creek – Bridge Approach and Joint Replacement Project

17. RESOLUTION

Council Member Jager to present a resolution approving the plans, specifications, and form of contract for the Devils Glen Road Over Duck Creek – Bridge Approach and Joint Replacement Project

18. PUBLIC HEARING

Regarding amending Title 11, Chapter 14 of the City Code – Sign Ordinance (Case 25-004-ORD)

19. ORDINANCE

Council Member Baden to present the first reading of an ordinance amending Title 11, Chapter 14 of the City Code – Sign Ordinance (Case 25-004-ORD)

20. CONSENT AGENDA

21. ADJOURN

CONSENT AGENDA

APRIL 15, 2025

ALL ITEMS APPEARING BELOW ARE CONSIDERED ROUTINE BY THE CITY COUNCIL AND SHALL BE ENACTED BY ONE MOTION. IF DISCUSSION IS DESIRED, THAT ITEM SHALL BE REMOVED AND DISCUSSED SEPARATELY

- A. Minutes from March 31, 2025, and April 1, 2025 (Approve and Adopt)
- B. Resolution setting the date for a public hearing and directing the advertising for bids for the Gateway Pedestrian Bridge & Trails Phase II Project. (Approve and Adopt)
- C. Resolution awarding the contract and approving the contract and bond for the 2025 Street Resurfacing Program. (Approve and Adopt)
- D. Resolution awarding the contract and approving the contract and bond for the Happy Joe Drive Reconstruction Project. (Approve and Adopt)
- E. Resolution approving an agreement with the Iowa Department of Transportation for intelligent transportation and security system integration for the I-74 Bridge area. (Approve and Adopt)
- F. Resolution approving the contract extension for the Turf Maintenance Services Contract for City Right-of-Way (Zone 1-2025). (Approve and Adopt)
- G. Resolution approving the contract extension for the Turf Maintenance Services Contract for City Right-of-Way (Zone 2-2025). (Approve and Adopt)
- H. Resolution authorizing the Director of Public Works to issue a purchase order to CDW Government for traffic network switches. (Approve and Adopt)
- I. Resolution establishing fees for mowing and yard sanitation for years 2025-2027 and selecting Kimberly's Kleaning as the contractor. (Approve and Adopt)
- J. Resolution certifying to the State Treasurer the actual population of the recently annexed area as determined by the last federal census of that area pursuant to Iowa Code Section 312.3(4). (Approve and Adopt)

- K. Resolution authorizing the Director of Parks and Recreation to issue a purchase order to BCI Burke Company, LLC for Ed Scheck Playground Equipment Replacement Project. (Approve and Adopt)
- L. Resolution approving mobile food unit licenses for Kona Ice (new owners), Uncle Sam's Kitchen, and Grilled Cheese Bar. (Approve and Adopt)
- M. Resolution approving alcohol license renewals and requests for CVS Store #8633, Home2 Suite by Hilton Bettendorf Quad Cities, Cambria Hotel Bettendorf Quad Cities, Iron Tee Golf, Purgatory's Pub, Isle of Capri Center, and The Isle Marina Bar. (Approve and Adopt)
- N. Bills (Approve payment and direct City Clerk to issue checks in respective amounts)



OFFICE OF THE MAYOR

PROCLAMATION

WHEREAS, *in 1872, J. Sterling Morton proposed to the Nebraska Board of Agriculture that a special day be set aside for the planting of trees; and*

WHEREAS, *this holiday, called Arbor Day, was first observed with the planting of more than a million trees in Nebraska; and*

WHEREAS, *Arbor Day is now observed throughout the nation and the world; and*

WHEREAS, *trees can reduce the erosion of our precious topsoil by wind and water, cut heating and cooling costs, moderate the temperature, clean the air, produce life-giving oxygen, and provide habitat for wildlife; and*

WHEREAS, *trees in our city increase property values, enhance the economic vitality of business areas, and beautify our community; and*

WHEREAS, *trees, wherever they are planted, are a source of joy and spiritual renewal.*

NOW, THEREFORE, I, Robert S. Gallagher, Mayor, of the city of Bettendorf, Iowa, do hereby proclaim **April 25, 2025,** as:

"ARBOR DAY"

in the Bettendorf community, and I urge all citizens to celebrate Arbor Day and to support efforts to protect our trees and woodlands.

IN WITNESS WHEREOF, *I have hereunto set my hand and caused the Seal of the city of Bettendorf, Iowa, to be affixed this 15th day of April, 2025.*

Mayor Robert S. Gallagher



OFFICE OF THE MAYOR

PROCLAMATION

- WHEREAS,** *emergencies occur around the clock and every day that require response from public safety resources; and*
- WHEREAS,** *the prompt processing of emergency calls and determining the correct response resources is critical to the protection of life and preservation of property; and*
- WHEREAS,** *the safety of our public safety professionals depends upon information obtained from those who dial 911 and reach the Scott Emergency Communications Center (SECC); and*
- WHEREAS,** *public safety dispatchers are the first and most critical contact our citizens have with emergency services; and*
- WHEREAS,** *public safety dispatchers are an essential safety line for our responders by monitoring their activities by radio, providing them information and ensuring their safety; and*
- WHEREAS,** *public safety dispatchers of the Scott Emergency Communications Center (SECC) contribute substantially to successful outcomes for law enforcement and medical responses; and*
- WHEREAS,** *unforeseen challenges may arise from time to time for the Public Safety Dispatchers of SECC, and those challenges are always met with professionalism, patience, compassion, and unending resolve.*

NOW, THEREFORE, *I, Robert S. Gallagher, Mayor of the city of Bettendorf, Iowa, do hereby proclaim the week of April 13 – 19, 2025, as:*

"NATIONAL PUBLIC SAFETY TELECOMMUNICATORS WEEK"

in the Bettendorf community and encourage all citizens to honor those whose diligence and professionalism keep us and our city safe.

IN WITNESS WHEREOF, *I have hereunto set my hand and caused the Seal of the city of Bettendorf, Iowa, to be affixed this 15th day of April, 2025.*

Mayor Robert S. Gallagher



OFFICE OF THE MAYOR

PROCLAMATION

WHEREAS, *the children within the city of Bettendorf are our most valuable resource and hope for the future of our community; and*

WHEREAS, *child abuse and neglect is a serious problem that can have long-term psychological, emotional, and physical effects that have lasting consequences for victims; and*

WHEREAS, *effective child abuse prevention activities succeed because of the partnerships created between child welfare professionals, education, health, community- and faith-based organizations, businesses, law enforcement agencies, and families, and*

WHEREAS, *we acknowledge that we must work together as a community to increase awareness about child abuse and the promotion of the social and emotional well-being of children and families in a safe, stable, and nurturing environment, whereby all victims can develop resiliency and heal from abuse-related trauma.*

NOW, THEREFORE, *I, Robert S. Gallagher, Mayor, of the city of Bettendorf, Iowa, do hereby proclaim the month of April as:*

"NATIONAL CHILD ABUSE PREVENTION MONTH"

in the Bettendorf community and urge all citizens to recognize this month by dedicating themselves to the task of improving the quality of life for all children and families in our community.

IN WITNESS WHEREOF, *I have hereunto set my hand and caused the Seal of the city of Bettendorf, Iowa, to be affixed this 15th day of April, 2025.*

Mayor Robert S. Gallagher



OFFICE OF THE MAYOR

PROCLAMATION

WHEREAS, *America's spirit of innovation thrives from the corner stores that define our neighborhoods to the cutting-edge startups driving progress, small businesses are the very foundation of our economic strength and the embodiment of the American dream; and*

WHEREAS, *supporting these businesses in the city of Bettendorf fosters job creation and safeguards the unique character of our community; and*

WHEREAS, *The President of the United States has proclaimed National Small Business Week each year since 1963, highlighting the valuable programs and services offered by the U.S. Small Business Administration and other government agencies to empower entrepreneurs; and*

WHEREAS, *the city of Bettendorf proudly joins this national effort.*

NOW, THEREFORE, *I, Robert S. Gallagher, Mayor of the city of Bettendorf, Iowa, hereby proclaim **May 4 - 10, 2025,** as:*

"NATIONAL SMALL BUSINESS WEEK"

in the Bettendorf community and encourage everyone to join this national effort in supporting our local small businesses to ensure the continued vibrancy of our community.

IN WITNESS WHEREOF, *I have hereunto set my hand and caused the Seal of the city of Bettendorf, Iowa, to be affixed this 15th day of April, 2025.*

Mayor Robert S. Gallagher

COUNCIL LETTER

MEETING DATE: April 15, 2025
REQUESTED BY: Jason Schadt, Finance Director



Item Title

Public hearing and resolution adopting the City of Bettendorf's FY 2025/26 Budget and Certification of Taxes.

Explanation

The Code of Iowa states that annually, a city shall prepare and adopt a budget, and shall certify property taxes to the County Auditor on or before the 30th day of April of each year.

The budget as presented in the attached state budget form titled "Adoption of Budget and Certification of City Taxes" reflects Administration's final compilation of the City's budget for FY 25/26, as directed by the Mayor and Council during several budget work sessions over the past several months. A public hearing regarding the proposed maximum property tax levy was held on 4/1/25. The 4/15/24 Public Hearing will be the second and final hearing regarding the budget.

In summary the FY 25/26:

- Allocates \$113 million of expenditures, net of internal services and transfers
- Demonstrates the City's financial strength and flexibility
- Funds current service levels across all departments despite rising costs and no increase in the levy rate
- Upholds the City's commitment to fully funding six firefighters currently paid by the SAFER grant
- Remains aggressive on infrastructure improvements such as streets and sewers

If the matter is not budgeted in the current year, explain why funding is requested and the anticipated source:

The attached resolution sets appropriations for the City's governmental activities and business type activities beginning 7/1/25. This appropriation will regulate expenditures for city operations through 6/30/26.

List Attachments

- Resolution
- Notice of Public Hearings
- Adoption of Budget and Certification of Taxes
- Additional State Budget Forms
- Public Hearing Presentation

RESOLUTION NO. _____ - 25

**RESOLUTION ADOPTING THE FISCAL YEAR 2025/26 BUDGET AND
CERTIFICATION OF TAXES**

BE IT RESOLVED BY THE CITY COUNCIL OF THE CITY OF
BETTENDORF, IOWA:

That the attached Annual Budget for FY 2025/26, Certification of Taxes and the
City's Capital Improvement Program are hereby approved and adopted.

PASSED, APPROVED, AND ADOPTED this 15th day of April, 2025.

Mayor Robert S. Gallagher

Attest:

Decker P. Ploehn, City Clerk

NOTICE OF PUBLIC HEARING -- PROPOSED BUDGET
Fiscal Year July 1, 2025 - June 30, 2026

City of: **BETTENDORF**

The City Council will conduct a public hearing on the proposed Budget at: 1609 State St. Bettendorf, Iowa Meeting Date: 4/15/2025 Meeting Time: 07:00 PM

At the public hearing any resident or taxpayer may present objections to, or arguments in favor of, any part of the proposed budget. This notice represents a summary of the supporting detail of revenues and expenditures on file with the City Clerk and County Auditor.

City budgets are subject to protest. If protest petition requirements are met, the State Appeal Board will hold a local hearing. For more information, consult <https://dom.iowa.gov/local-budget-appeals>.

The Budget Estimate Summary of proposed receipts and expenditures is shown below. Copies of the the detailed proposed Budget may be obtained or viewed at the offices of the Mayor, City Clerk, and at the Library.

The estimated Total tax levy rate per \$1000 valuation on regular property 13.11000

The estimated tax levy rate per \$1000 valuation on Agricultural property is 3.00375

At the public hearing, any resident or taxpayer may present objections to, or arguments in favor of, any part of the proposed budget.

Phone Number
(563) 344-4116

City Clerk/Finance Officer's NAME
Jason Schadt

		Budget FY 2026	Re-estimated FY 2025	Actual FY 2024
Revenues & Other Financing Sources				
Taxes Levied on Property	1	39,033,212	37,688,585	34,696,216
Less: Uncollected Property Taxes-Levy Year	2	0	0	0
Net Current Property Taxes	3	39,033,212	37,688,585	34,696,216
Delinquent Property Taxes	4	5,000	5,000	0
TIF Revenues	5	4,077,651	3,603,844	3,531,215
Other City Taxes	6	12,127,382	11,811,007	11,782,554
Licenses & Permits	7	1,438,250	1,578,250	1,559,903
Use of Money and Property	8	1,620,035	1,869,338	3,466,547
Intergovernmental	9	12,040,056	10,269,204	18,169,740
Charges for Fees & Service	10	30,272,237	28,993,807	32,093,364
Special Assessments	11	13,500	13,500	13,737
Miscellaneous	12	3,552,620	4,687,897	1,593,571
Other Financing Sources	13	11,675,000	16,775,000	17,620,156
Transfers In	14	7,142,556	9,615,239	12,811,183
Total Revenues and Other Sources	15	122,997,499	126,910,671	137,338,186
Expenditures & Other Financing Uses				
Public Safety	16	18,157,678	17,579,807	15,754,715
Public Works	17	4,467,716	4,269,833	3,858,148
Health and Social Services	18	0	0	0
Culture and Recreation	19	7,365,199	7,059,241	6,124,349
Community and Economic Development	20	6,043,463	5,427,518	7,652,889
General Government	21	6,502,343	6,265,972	5,331,003
Debt Service	22	16,842,460	15,600,087	15,624,463
Capital Projects	23	32,439,413	26,045,584	23,300,162
Total Government Activities Expenditures	24	91,818,272	82,248,042	77,645,729
Business Type / Enterprises	25	33,479,148	32,107,629	28,668,471
Total ALL Expenditures	26	125,297,420	114,355,671	106,314,200
Transfers Out	27	7,142,556	9,615,239	12,811,183
Total ALL Expenditures/Transfers Out	28	132,439,976	123,970,910	119,125,383
Excess Revenues & Other Sources Over (Under) Expenditures/Transfers Out	29	-9,442,477	2,939,761	18,212,803
Beginning Fund Balance July 1	30	147,967,298	145,027,537	126,814,734
Ending Fund Balance June 30	31	138,524,821	147,967,298	145,027,537

The City Council will conduct a public hearing on the proposed Fiscal Year City property tax levy as follows:

Meeting Date: 4/1/2025 Meeting Time: 06:30 PM Meeting Location: 1609 State St. Bettendorf, Iowa 52722

At the public hearing any resident or taxpayer may present objections to, or arguments in favor of the proposed tax levy. After the hearing of the proposed tax levy, the City Council will publish notice and hold a hearing on the proposed city budget.

City Website (if available)
www.bettendorf.org

City Telephone Number
(563) 344-4116

Iowa Department of Management	Current Year Certified Property Tax 2024 - 2025	Budget Year Effective Property Tax 2025 - 2026	Budget Year Proposed Property Tax 2025 - 2026
Taxable Valuations for Non-Debt Service	2,804,615,140	2,899,288,031	2,899,288,031
Consolidated General Fund	21,447,060	21,447,060	21,951,524
Operation & Maintenance of Public Transit	339,527	339,527	408,974
Aviation Authority	0	0	0
Liability, Property & Self Insurance	132,742	132,742	298,743
Support of Local Emergency Mgmt. Comm.	0	0	0
Unified Law Enforcement	0	0	0
Police & Fire Retirement	874,703	874,703	904,230
FICA & IPERS (If at General Fund Limit)	0	0	0
Other Employee Benefits	372,088	372,088	384,649
Capital Projects (Capital Improv. Reserve)	0	0	0
Taxable Value for Debt Service	2,947,373,656	3,063,429,058	3,063,429,058
Debt Service	14,294,762	14,294,762	14,857,631
CITY REGULAR TOTAL PROPERTY TAX	37,460,882	37,460,882	38,805,751
CITY REGULAR TAX RATE	13.11000	12.65654	13.11000
Taxable Value for City Ag Land	5,050,503	5,010,425	5,010,425
Ag Land	15,170	15,170	15,051
CITY AG LAND TAX RATE	3.00375	3.02769	3.00375
Tax Rate Comparison-Current VS. Proposed			
Residential property with an Actual/Assessed Valuation of \$100,000/\$110,000	Current Year Certified 2024/2025	Budget Year Proposed 2025/2026	Percent Change
City Regular Residential	608	684	12.50
Commercial property with an Actual/Assessed Valuation of \$300,000/\$330,000	Current Year Certified 2024/2025	Budget Year Proposed 2025/2026	Percent Change
City Regular Commercial	2,681	3,057	14.02

Note: Actual/Assessed Valuation is multiplied by a Rollback Percentage to get to the Taxable Valuation to calculate Property Taxes. Residential and commercial properties have the same rollback percentage through \$150,000 of actual/assessed valuation.

Reasons for tax increase if proposed exceeds the current:

Increased tax dollars are required to fund existing operations. The FY26 budget does not include additional staffing. The City is experiencing rising costs in labor, equipment, liability insurance and health insurance similar to private sector.

**FISCAL YEAR JULY 1, 2025 - JUNE 30, 2026
ADOPTION OF BUDGET AND CERTIFICATION OF CITY TAXES**

The City of : **BETTENDORF** County Name: **SCOTT COUNTY**

Adopted On: (entered upon adoption) Resolution: (entered upon adoption)

The below-signed certifies that the City Council, on the date stated above, lawfully approved the named resolution adopting a budget for next fiscal year, as summarized on this and the supporting pages.

Attached is Long Term Debt Schedule Form 703 which lists any and all of the debt service obligations of the City.

		With Gas & Electric		Without Gas & Electric	City Number: 82-770 Last Official Census: 39,102
Regular	2a	2,966,385,307	2b	2,899,288,031	
DEBT SERVICE	3a	3,130,526,334	3b	3,063,429,058	
Ag Land	4a	5,010,425			

Consolidated General Fund Levy Calculation

	CGFL Rate	CGFL Dollars	Non-TIF Taxable w/ G&E	Taxable Growth %
FY 2025 Budget Data	7.64706	21,930,219	2,867,797,486	3.44
	Limitation Percentage			
	1			
	CGFL Max Rate	CGFL Max Dollars	Revenue Growth %	
Max Allowed CGFL for FY 2026	7.57135	22,459,541	2.41	

TAXES LEVIED

Code Sec.	Dollar Limit	Purpose	ENTER FIRE DISTRICT RATE BELOW		(A) Request with Utility Replacement	(B) Property Taxes Levied		(C) Rate
384.1	7.57135	Consolidated General Fund			5	22,459,541	21,951,524	43 7.57135
		Non-Voted Other Permissible Levies						
384.12(1)	0.95000	Opr & Maint publicly owned Transit			7	418,438	408,974	45 0.14106
384.12(2)	0.27000	Aviation Authority (under sec.330A.15)			11		0	49 0.00000
384.12(3)	Amt Nec	Liability, property & self insurance costs			14	305,656	298,743	52 0.10304
384.12(5)	Amt Nec	Support of a Local Emerg.Mgmt.Comm.			462		0	465 0.00000
		Voted Other Permissible Levies						
28E.22	1.50000	Unified Law Enforcement			24		0	62 0.00000
		Total General Fund Regular Levies (5 thru 24)			25	23,183,635	22,659,241	
384.1	3.00375	Ag Land			26	15,051	15,051	63 3.00375
		Total General Fund Tax Levies (25 + 26)			27	23,198,686	22,674,292	Do Not Add
		Special Revenue Levies						
384.6	Amt Nec	Police & Fire Retirement			29	925,156	904,230	0.31188
	Amt Nec	FICA & IPERS (if general fund at levy limit)			30		0	0.00000
Rules	Amt Nec	Other Employee Benefits			31	393,550	384,649	0.13267
		Subtotal Employee Benefit Levy (29,30,31)			32	1,318,706	1,288,879	65 0.44455
			Valuation					
386	As Req	With Gas & Elec		Without Gas & Elec				
	SSMID 1 (A)	77,240,162 (B)		77,240,162	34	212,410	212,410	66 2.74999
	SSMID 2 (A)	0 (B)		0	35		0	67 0.00000
	SSMID 3 (A)	0 (B)		0	36		0	68 0.00000
	SSMID 4 (A)	0 (B)		0	37		0	69 0.00000
	SSMID 5 (A)	0 (B)		0	555		0	565 0.00000
	SSMID 6 (A)	0 (B)		0	556		0	566 0.00000
	SSMID 7 (A)	0 (B)		0	1177		0	1179 0.00000
	SSMID 8 (A)	0 (B)		0	1185		0	1187 0.00000
		Total Special Revenue Levies			39	1,531,116	1,501,289	
384.4	Amt Nec	Debt Service Levy 76.10(6)			40	15,183,053	14,857,631	70 4.85000
384.7	0.67500	Capital Projects (Capital Improv. Reserve)			41		0	71 0.00000
		Total Property Taxes (27+39+40+41)			42	39,912,855	39,033,212	72 13.11000

COUNTY AUDITOR - I certify the budget is in compliance with ALL the following: Budgets that DO NOT meet ALL the criteria below are not statutorily compliant & must be returned to the city for correction.

(City Representative)

(Date)

(County Auditor)

(Date)

FUND BALANCE

City Name: **BETTENDORF**
 Fiscal Year July 1, 2025 - June 30, 2026

		GENERAL	SPECIAL REVENUES	TIF SPECIAL REVENUES	DEBT SERVICE	CAPITAL PROJECTS	PERMANENT	TOTAL GOVERNMENT	PROPRIETARY	GRAND TOTAL
Annual Report FY 2024										
Beginning Fund Balance July 1	1	15,590,770	5,304,638	481,370	1,048,157	23,865,854	0	46,290,789	80,523,945	126,814,734
Actual Revenues Except Beg Balance	2	34,418,272	11,608,847	3,569,461	14,918,273	26,527,744	0	91,042,597	46,295,589	137,338,186
Actual Expenditures Except End Balance	3	32,264,657	11,729,740	3,478,435	14,849,670	28,134,410	0	90,456,912	28,668,471	119,125,383
Ending Fund Balance June 30	4	17,744,385	5,183,745	572,396	1,116,760	22,259,188	0	46,876,474	98,151,063	145,027,537
Re-Estimated FY 2025										
Beginning Fund Balance	5	17,744,385	5,183,745	572,396	1,116,760	22,259,188	0	46,876,474	98,151,063	145,027,537
Re-Est Revenues	6	36,834,089	8,088,501	3,603,844	15,003,441	27,945,941	0	91,475,816	35,434,855	126,910,671
Re-Est Expenditures	7	36,517,343	8,841,119	3,627,616	15,123,397	27,603,806	0	91,713,281	32,257,629	123,970,910
Ending Fund Balance	8	18,061,131	4,431,127	548,624	996,804	22,601,323	0	46,639,009	101,328,289	147,967,298
Budget FY 2026										
Beginning Fund Balance	9	18,061,131	4,431,127	548,624	996,804	22,601,323	0	46,639,009	101,328,289	147,967,298
Revenues	10	37,724,282	7,856,119	4,077,651	15,594,771	21,757,750	0	87,010,573	35,986,926	122,997,499
Expenditures	11	36,892,655	8,737,870	4,265,231	16,365,770	32,549,302	0	98,810,828	33,629,148	132,439,976
Ending Fund Balance	12	18,892,758	3,549,376	361,044	225,805	11,809,771	0	34,838,754	103,686,067	138,524,821

LOCAL EMC SUPPORT

City Name: BETTENDORF
Fiscal Year July 1, 2025 - June 30, 2026

As provided in Iowa Code Section 384.12, subsection 22, a city may levy the amount necessary in support of a local Emergency Management Commission. In addition to this individual levy, Emergency Management Commission support may also be included as part of the General Fund Levy. Iowa Code Section 29C.17, subsection 6 states that any support from cities or counties must be separately reported on tax statements issued by the county treasurer. Input the amount of General Fund Levy request to be used for support of an Emergency Management Commission. The total below will reflect the total amount of Emergency Management Commission support provided by the City.

	Request with Utility Replacement	Property Taxes Levied
Portion of General Fund Levy Used for Emerg. Mgmt. Comm.		0
Support of a Local Emerg.Mgmt.Comm.	0	0
TOTAL FOR FY 2026	0	0

RE-ESTIMATED EXPENDITURES SCHEDULE PAGE 1

City Name: BETTENDORF
Fiscal Year July 1, 2024 - June 30, 2025

GOVERNMENT ACTIVITIES CONT.		GENERAL	SPECIAL REVENUE	TIF SPECIAL REVENUES	DEBT SERVICE	CAPITAL PROJECTS	PERMANENT	PROPRIETARY	RE-ESTIMATED 2025	ACTUAL 2024
PUBLIC SAFETY										
Police Department/Crime Prevention	1	10,120,054	51,000						10,171,054	9,222,483
Jail	2								0	0
Emergency Management	3		7,048						7,048	1,470
Flood Control	4								0	0
Fire Department	5	6,553,783							6,553,783	5,783,453
Ambulance	6								0	0
Building Inspections	7	847,922							847,922	747,309
Miscellaneous Protective Services	8								0	0
Animal Control	9								0	0
Other Public Safety	10								0	0
TOTAL (lines 1 - 10)	11	17,521,759	58,048				0		17,579,807	15,754,715
PUBLIC WORKS										
Roads, Bridges, & Sidewalks	12		1,446,317						1,446,317	1,361,269
Parking - Meter and Off-Street	13								0	0
Street Lighting	14		260,000						260,000	231,994
Traffic Control and Safety	15		583,621						583,621	512,364
Snow Removal	16		1,042,215						1,042,215	977,264
Highway Engineering	17		320,896						320,896	282,629
Street Cleaning	18		1,384						1,384	1,076
Airport (if not Enterprise)	19								0	0
Garbage (if not Enterprise)	20								0	0
Other Public Works	21		615,400						615,400	491,552
TOTAL (lines 12 - 21)	22	0	4,269,833				0		4,269,833	3,858,148
HEALTH & SOCIAL SERVICES										
Welfare Assistance	23								0	0
City Hospital	24								0	0
Payments to Private Hospitals	25								0	0
Health Regulation and Inspection	26								0	0
Water, Air, and Mosquito Control	27								0	0
Community Mental Health	28								0	0
Other Health and Social Services	29								0	0
TOTAL (lines 23 - 29)	30	0	0				0		0	0
CULTURE & RECREATION										
Library Services	31	3,708,444	73,900						3,782,344	3,325,693
Museum, Band and Theater	32								0	0
Parks	33	1,809,703							1,809,703	1,607,093
Recreation	34	1,239,873							1,239,873	952,479
Cemetery	35								0	0
Community Center, Zoo, & Marina	36	93,321							93,321	111,714
Other Culture and Recreation	37	134,000							134,000	127,370
TOTAL (lines 31 - 37)	38	6,985,341	73,900				0		7,059,241	6,124,349

RE-ESTIMATED EXPENDITURES SCHEDULE PAGE 2

City Name: BETTENDORF
Fiscal Year July 1, 2024 - June 30, 2025

GOVERNMENT ACTIVITIES CONT.		GENERAL	SPECIAL REVENUE	TIF SPECIAL REVENUES	DEBT SERVICE	CAPITAL PROJECTS	PERMANENT	PROPRIETARY	RE-ESTIMATED 2025	ACTUAL 2024
COMMUNITY & ECONOMIC DEVELOPMENT										
Community Beautification	39	215,000	25,000						240,000	165,311
Economic Development	40	506,208							506,208	6,479,742
Housing and Urban Renewal	41								0	0
Planning & Zoning	42	556,913							556,913	399,161
Other Com & Econ Development	43	759,902							759,902	608,675
TIF Rebates	44		211,069	3,153,426					3,364,495	0
TOTAL (lines 39 - 44)	45	2,038,023	236,069	3,153,426			0		5,427,518	7,652,889
GENERAL GOVERNMENT										
Mayor, Council, & City Manager	46	1,590,088							1,590,088	1,177,080
Clerk, Treasurer, & Finance Adm.	47	1,004,600							1,004,600	925,688
Elections	48								0	12,952
Legal Services & City Attorney	49	481,070							481,070	435,494
City Hall & General Buildings	50	1,181,609							1,181,609	989,132
Tort Liability	51	912,599							912,599	910,180
Other General Government	52	1,096,006							1,096,006	880,477
TOTAL (lines 46 - 52)	53	6,265,972	0	0			0		6,265,972	5,331,003
DEBT SERVICE										
Gov Capital Projects	54	2,500		474,190	15,123,397				15,600,087	15,624,463
TIF Capital Projects	55	542,886	2,847,153			22,655,545			26,045,584	23,300,162
TIF Capital Projects	56								0	0
TOTAL CAPITAL PROJECTS	57	542,886	2,847,153	0		22,655,545	0		26,045,584	23,300,162
TOTAL Governmental Activities Expenditures (lines 11+22+30+38+44+52+53+54)	58	33,356,481	7,485,003	3,627,616	15,123,397	22,655,545	0		82,248,042	77,645,729
BUSINESS TYPE ACTIVITIES Proprietary: Enterprise & Budgeted ISF										
Water Utility	59								0	0
Sewer Utility	60							5,139,064	5,139,064	4,577,902
Electric Utility	61								0	0
Gas Utility	62								0	0
Airport	63								0	0
Landfill/Garbage	64							3,386,069	3,386,069	2,997,225
Transit	65							1,810,489	1,810,489	1,457,189
Cable TV, Internet & Telephone	66								0	0
Housing Authority	67								0	0
Storm Water Utility	68							1,850,224	1,850,224	1,631,930
Other Business Type (city hosp., ISF, parking, etc.)	69							19,152,704	19,152,704	17,284,975
Enterprise DEBT SERVICE	70							769,079	769,079	719,250
Enterprise CAPITAL PROJECTS	71								0	0
Enterprise TIF CAPITAL PROJECTS	72								0	0
TOTAL BUSINESS TYPE EXPENDITURES (lines 59+72)	73							32,107,629	32,107,629	28,668,471
TOTAL ALL EXPENDITURES (lines 58+73)	74	33,356,481	7,485,003	3,627,616	15,123,397	22,655,545	0	32,107,629	114,355,671	106,314,200
Regular Transfers Out	75	3,160,862	1,356,116			4,948,261		150,000	9,615,239	12,781,406
Internal TIF Loan Transfers Out	76								0	29,777
Total ALL Transfers Out	77	3,160,862	1,356,116	0	0	4,948,261	0	150,000	9,615,239	12,811,183
Total Expenditures and Other Fin Uses (lines 74+77)	78	36,517,343	8,841,119	3,627,616	15,123,397	27,603,806	0	32,257,629	123,970,910	119,125,383
Ending Fund Balance June 30	79	18,061,131	4,431,127	548,624	996,804	22,601,323	0	101,328,289	147,967,298	145,027,537

RE-ESTIMATED REVENUES DETAIL

City Name: BETTENDORF
 Fiscal Year July 1, 2024 - June 30, 2025

REVENUES & OTHER FINANCING SOURCES		GENERAL	SPECIAL REVENUE	TIF SPECIAL REVENUES	DEBT SERVICE	CAPITAL PROJECTS	PERMANENT	PROPRIETARY	RE-ESTIMATED 2025	ACTUAL 2024
Taxes Levied on Property	1	21,934,499	1,459,324		14,294,762				37,688,585	34,696,216
Less: Uncollected Property Taxes - Levy Year	2								0	0
Net Current Property Taxes (line 1 minus line 2)	3	21,934,499	1,459,324		14,294,762	0			37,688,585	34,696,216
Delinquent Property Taxes	4	3,000			2,000				5,000	0
TIF Revenues	5			3,603,844					3,603,844	3,531,215
Other City Taxes:										
Utility Tax Replacement Excise Taxes	6	501,383	28,089		309,735				839,207	811,801
Utility franchise tax (Iowa Code Chapter 364.2)	7	200,000							200,000	234,213
Parimutuel wager tax	8								0	0
Gaming wager tax	9	1,365,000							1,365,000	1,373,921
Mobile Home Taxes	10	3,800			3,000				6,800	14,891
Hotel/Motel Taxes	11	1,500,000							1,500,000	1,318,266
Other Local Option Taxes	12	4,740,000				3,160,000			7,900,000	8,029,462
Subtotal - Other City Taxes (lines 6 thru 12)	13	8,310,183	28,089		312,735	3,160,000			11,811,007	11,782,554
Licenses & Permits	14	1,370,750						207,500	1,578,250	1,559,903
Use of Money & Property	15	448,010	105,513		100,000	536,300		679,515	1,869,338	3,466,547
Intergovernmental:										
Federal Grants & Reimbursements	16	734,369	40,000			1,176,221		943,402	2,893,992	9,468,327
Road Use Taxes	17		5,680,000						5,680,000	5,569,255
Other State Grants & Reimbursements	18	651,606	122,803		293,944	109,659		265,000	1,443,012	2,896,574
Local Grants & Reimbursements	19	252,200							252,200	235,584
Subtotal - Intergovernmental (lines 16 thru 19)	20	1,638,175	5,842,803	0	293,944	1,285,880		1,208,402	10,269,204	18,169,740
Charges for Fees & Service:										
Water Utility	21								0	0
Sewer Utility	22							6,040,463	6,040,463	5,328,764
Electric Utility	23								0	0
Gas Utility	24								0	0
Parking	25								0	0
Airport	26								0	0
Landfill/Garbage	27							3,540,505	3,540,505	3,507,706
Hospital	28								0	0
Transit	29							60,975	60,975	55,463
Cable TV, Internet & Telephone	30								0	0
Housing Authority	31								0	0
Storm Water Utility	32							2,863,279	2,863,279	2,620,965
Other Fees & Charges for Service	33	1,248,500						15,240,085	16,488,585	20,580,466
Subtotal - Charges for Service (lines 21 thru 33)	34	1,248,500	0		0	0	0	27,745,307	28,993,807	32,093,364
Special Assessments	35	11,500				2,000			13,500	13,737
Miscellaneous	36	473,597	479,000			261,500		3,473,800	4,687,897	1,593,571
Other Financing Sources:										
Regular Operating Transfers In	37	1,395,875	173,772			5,925,261		2,120,331	9,615,239	12,781,406
Internal TIF Loan Transfers In	38								0	29,777
Subtotal ALL Operating Transfers In	39	1,395,875	173,772	0	0	5,925,261	0	2,120,331	9,615,239	12,811,183
Proceeds of Debt (Excluding TIF Internal Borrowing)	40					16,700,000			16,700,000	17,412,175
Proceeds of Capital Asset Sales	41					75,000			75,000	207,981
Subtotal-Other Financing Sources (lines 36 thru 38)	42	1,395,875	173,772	0	0	22,700,261	0	2,120,331	26,390,239	30,431,339
Total Revenues except for beginning fund balance (lines 3, 4, 5, 12, 13, 14, 19, 33, 34, 35, & 39)	43	36,834,089	8,088,501	3,603,844	15,003,441	27,945,941	0	35,434,855	126,910,671	137,338,186
Beginning Fund Balance July 1	44	17,744,385	5,183,745	572,396	1,116,760	22,259,188	0	98,151,063	145,027,537	126,814,734
TOTAL REVENUES & BEGIN BALANCE (lines 41+42)	45	54,578,474	13,272,246	4,176,240	16,120,201	50,205,129	0	133,585,918	271,938,208	264,152,920

EXPENDITURES SCHEDULE PAGE 1

City Name: **BETTENDORF**
Fiscal Year July 1, 2025 - June 30, 2026

GOVERNMENT ACTIVITIES		GENERAL	SPECIAL REVENUES	TIF SPECIAL REVENUES	DEBT SERVICE	CAPITAL PROJECTS	PERMANENT	PROPRIETARY	BUDGET 2026	RE-ESTIMATED 2025	ACTUAL 2024
PUBLIC SAFETY											
Police Department/Crime Prevention	1	10,318,947	46,000						10,364,947	10,171,054	9,222,483
Jail	2								0	0	0
Emergency Management	3								0	7,048	1,470
Flood Control	4								0	0	0
Fire Department	5	6,872,917							6,872,917	6,553,783	5,783,453
Ambulance	6								0	0	0
Building Inspections	7	919,814							919,814	847,922	747,309
Miscellaneous Protective Services	8								0	0	0
Animal Control	9								0	0	0
Other Public Safety	10								0	0	0
TOTAL (lines 1 - 10)	11	18,111,678	46,000				0		18,157,678	17,579,807	15,754,715
PUBLIC WORKS											
Roads, Bridges, & Sidewalks	12		1,574,257						1,574,257	1,446,317	1,361,269
Parking - Meter and Off-Street	13								0	0	0
Street Lighting	14		260,000						260,000	260,000	231,994
Traffic Control and Safety	15		588,925						588,925	583,621	512,364
Snow Removal	16		1,062,501						1,062,501	1,042,215	977,264
Highway Engineering	17		338,352						338,352	320,896	282,629
Street Cleaning	18		1,400						1,400	1,384	1,076
Airport	19								0	0	0
Garbage (if not Enterprise)	20								0	0	0
Other Public Works	21		642,281						642,281	615,400	491,552
TOTAL (lines 12 - 21)	22	0	4,467,716				0		4,467,716	4,269,833	3,858,148
HEALTH & SOCIAL SERVICES											
Welfare Assistance	23								0	0	0
City Hospital	24								0	0	0
Payments to Private Hospitals	25								0	0	0
Health Regulation and Inspection	26								0	0	0
Water, Air, and Mosquito Control	27								0	0	0
Community Mental Health	28								0	0	0
Other Health and Social Services	29								0	0	0
TOTAL (lines 23 - 29)	30	0	0				0		0	0	0
CULTURE & RECREATION											
Library Services	31	3,938,952	73,900						4,012,852	3,782,344	3,325,693
Museum, Band and Theater	32								0	0	0
Parks	33	1,817,140							1,817,140	1,809,703	1,607,093
Recreation	34	1,279,289							1,279,289	1,239,873	952,479
Cemetery	35								0	0	0
Community Center, Zoo, & Marina	36	121,918							121,918	93,321	111,714
Other Culture and Recreation	37	134,000							134,000	134,000	127,370
TOTAL (lines 31 - 37)	38	7,291,299	73,900				0		7,365,199	7,059,241	6,124,349

City Name: **BETTENDORF**
Fiscal Year July 1, 2025 - June 30, 2026

GOVERNMENT ACTIVITIES		GENERAL	SPECIAL REVENUES	TIF SPECIAL REVENUES	DEBT SERVICE	CAPITAL PROJECTS	PERMANENT	PROPRIETARY	BUDGET 2026	RE-ESTIMATED 2025	ACTUAL 2024
COMMUNITY & ECONOMIC DEVELOPMENT											
Community Beautification	39	230,000	25,000						255,000	240,000	165,311
Economic Development	40	507,570		208,700					716,270	506,208	6,479,742
Housing and Urban Renewal	41								0	0	0
Planning & Zoning	42	693,441							693,441	556,913	399,161
Other Com & Econ Development	43	796,411							796,411	759,902	608,675
TIF Rebates	44			3,582,341					3,582,341	3,364,495	0
TOTAL (lines 39 - 44)	45	2,227,422	25,000	3,791,041			0		6,043,463	5,427,518	7,652,889
GENERAL GOVERNMENT											
Mayor, Council, & City Manager	46	1,614,490							1,614,490	1,590,088	1,177,080
Clerk, Treasurer, & Finance Adm.	47	1,076,176							1,076,176	1,004,600	925,688
Elections	48	20,000							20,000	0	12,952
Legal Services & City Attorney	49	468,534							468,534	481,070	435,494
City Hall & General Buildings	50	1,225,901							1,225,901	1,181,609	989,132
Tort Liability	51	951,246							951,246	912,599	910,180
Other General Government	52	1,145,996							1,145,996	1,096,006	880,477
TOTAL (lines 46 - 52)	53	6,502,343	0	0			0		6,502,343	6,265,972	5,331,003
DEBT SERVICE	54	2,500		474,190	16,365,770				16,842,460	15,600,087	15,624,463
Gov Capital Projects	55	528,886	2,713,725			29,196,802			32,439,413	26,045,584	23,300,162
TIF Capital Projects	56								0	0	0
TOTAL CAPITAL PROJECTS	57	528,886	2,713,725	0		29,196,802	0		32,439,413	26,045,584	23,300,162
TOTAL Government Activities Expenditures (lines 11+22+30+38+45+53+54+57)	58	34,664,128	7,326,341	4,265,231	16,365,770	29,196,802	0		91,818,272	82,248,042	77,645,729
BUSINESS TYPE ACTIVITIES											
Proprietary: Enterprise & Budgeted ISF											
Water Utility	59								0	0	0
Sewer Utility	60							5,379,447	5,379,447	5,139,064	4,577,902
Electric Utility	61								0	0	0
Gas Utility	62								0	0	0
Airport	63								0	0	0
Landfill/Garbage	64							3,394,999	3,394,999	3,386,069	2,997,225
Transit	65							1,892,424	1,892,424	1,810,489	1,457,189
Cable TV, Internet & Telephone	66								0	0	0
Housing Authority	67								0	0	0
Storm Water Utility	68							1,944,139	1,944,139	1,850,224	1,631,930
Other Business Type (city hosp., ISF, parking, etc.)	69							19,990,946	19,990,946	19,152,704	17,284,975
Enterprise DEBT SERVICE	70							877,193	877,193	769,079	719,250
Enterprise CAPITAL PROJECTS	71								0	0	0
Enterprise TIF CAPITAL PROJECTS	72								0	0	0
TOTAL Business Type Expenditures (lines 59 - 72)	73							33,479,148	33,479,148	32,107,629	28,668,471
TOTAL ALL EXPENDITURES (lines 58 + 73)	74	34,664,128	7,326,341	4,265,231	16,365,770	29,196,802	0	33,479,148	125,297,420	114,355,671	106,314,200
Regular Transfers Out	75	2,228,527	1,411,529			3,352,500		150,000	7,142,556	9,615,239	12,781,406
Internal TIF Loan / Repayment Transfers Out	76								0	0	29,777
Total ALL Transfers Out	77	2,228,527	1,411,529	0	0	3,352,500	0	150,000	7,142,556	9,615,239	12,811,183
Total Expenditures & Fund Transfers Out (lines 74+77)	78	36,892,655	8,737,870	4,265,231	16,365,770	32,549,302	0	33,629,148	132,439,976	123,970,910	119,125,383
Ending Fund Balance June 30	79	18,892,758	3,549,376	361,044	225,805	11,809,771	0	103,686,067	138,524,821	147,967,298	145,027,537

REVENUES DETAIL

City Name: BETTENDORF
 Fiscal Year July 1, 2025 - June 30, 2026

		GENERAL	SPECIAL REVENUES	TIF SPECIAL REVENUES	DEBT SERVICE	CAPITAL PROJECTS	PERMANENT	PROPRIETARY	BUDGET 2026	RE-ESTIMATED 2025	ACTUAL 2024
REVENUES & OTHER FINANCING SOURCES											
Taxes Levied on Property	1	22,674,292	1,501,289		14,857,631	0			39,033,212	37,688,585	34,696,216
Less: Uncollected Property Taxes - Levy Year	2								0	0	0
Net Current Property Taxes (line 1 minus line 2)	3	22,674,292	1,501,289		14,857,631	0			39,033,212	37,688,585	34,696,216
Delinquent Property Taxes	4	3,000			2,000				5,000	5,000	0
TIF Revenues	5			4,077,651					4,077,651	3,603,844	3,531,215
Other City Taxes:											
Utility Tax Replacement Excise Taxes	6	524,394	29,827		325,422	0			879,643	839,207	811,801
Utility franchise tax (Iowa Code Chapter 364.2)	7	180,000							180,000	200,000	234,213
Parimutuel wager tax	8								0	0	0
Gaming wager tax	9	1,400,000							1,400,000	1,365,000	1,373,921
Mobile Home Taxes	10	11,439			6,300				17,739	6,800	14,891
Hotel/Motel Taxes	11	1,550,000							1,550,000	1,500,000	1,318,266
Other Local Option Taxes	12	4,860,000				3,240,000			8,100,000	7,900,000	8,029,462
Subtotal - Other City Taxes (lines 6 thru 12)	13	8,525,833	29,827		331,722	3,240,000			12,127,382	11,811,007	11,782,554
Licenses & Permits	14	1,230,750						207,500	1,438,250	1,578,250	1,559,903
Use of Money & Property	15	442,010	95,510		100,000	382,750		599,765	1,620,035	1,869,338	3,466,547
Intergovernmental:											
Federal Grants & Reimbursements	16	759,467	25,000			3,000,000		864,097	4,648,564	2,893,992	9,468,327
Road Use Taxes	17		5,790,000						5,790,000	5,680,000	5,569,255
Other State Grants & Reimbursements	18	622,163	118,162		257,967	75,000		270,000	1,343,292	1,443,012	2,896,574
Local Grants & Reimbursements	19	258,200							258,200	252,200	235,584
Subtotal - Intergovernmental (lines 16 thru 19)	20	1,639,830	5,933,162	0	257,967	3,075,000		1,134,097	12,040,056	10,269,204	18,169,740
Charges for Fees & Service:											
Water Utility	21								0	0	0
Sewer Utility	22							6,431,499	6,431,499	6,040,463	5,328,764
Electric Utility	23								0	0	0
Gas Utility	24								0	0	0
Parking	25								0	0	0
Airport	26								0	0	0
Landfill/Garbage	27							3,608,274	3,608,274	3,540,505	3,507,706
Hospital	28								0	0	0
Transit	29							1,134,097	1,134,097	60,975	55,463
Cable TV, Internet & Telephone	30								0	0	0
Housing Authority	31								0	0	0
Storm Water Utility	32							2,955,556	2,955,556	2,863,279	2,620,965
Other Fees & Charges for Service	33	1,239,000						14,903,811	16,142,811	16,488,585	20,580,466
Subtotal - Charges for Service (lines 21 thru 33)	34	1,239,000	0		0	0	0	29,033,237	30,272,237	28,993,807	32,093,364
Special Assessments	35	11,500				2,000			13,500	13,500	13,737
Miscellaneous	36	521,320	122,000			83,000		2,826,300	3,552,620	4,687,897	1,593,571
Other Financing Sources:											
Regular Operating Transfers In	37	1,436,747	174,331		45,451	3,300,000		2,186,027	7,142,556	9,615,239	12,781,406
Internal TIF Loan Transfers In	38								0	0	29,777
Subtotal ALL Operating Transfers In	39	1,436,747	174,331	0	45,451	3,300,000	0	2,186,027	7,142,556	9,615,239	12,811,183
Proceeds of Debt (Excluding TIF Internal Borrowing)	40					11,600,000			11,600,000	16,700,000	17,412,175
Proceeds of Capital Asset Sales	41					75,000			75,000	75,000	207,981
Subtotal-Other Financing Sources (lines 38 thru 40)	42	1,436,747	174,331	0	45,451	14,975,000	0	2,186,027	18,817,556	26,390,239	30,431,339
Total Revenues except for beginning fund balance (lines 3, 4, 5, 13, 14, 15, 20, 34, 35, 36, & 41)	43	37,724,282	7,856,119	4,077,651	15,594,771	21,757,750	0	35,986,926	122,997,499	126,910,671	137,338,186
Beginning Fund Balance July 1	44	18,061,131	4,431,127	548,624	996,804	22,601,323	0	101,328,289	147,967,298	145,027,537	126,814,734
TOTAL REVENUES & BEGIN BALANCE (lines 42+43)	45	55,785,413	12,287,246	4,626,275	16,591,575	44,359,073	0	137,315,215	270,964,797	271,938,208	264,152,920

ADOPTED BUDGET SUMMARY

City Name: **BETTENDORF**
Fiscal Year July 1, 2025 - June 30, 2026

		GENERAL	SPECIAL REVENUES	TIF SPECIAL REVENUES	DEBT SERVICE	CAPITAL PROJECTS	PERMANENT	PROPRIETARY	BUDGET 2026	RE-ESTIMATED 2025	ACTUAL 2024
Revenues & Other Financing Sources											
Taxes Levied on Property	1	22,674,292	1,501,289		14,857,631	0			39,033,212	37,688,585	34,696,216
Less: Uncollected Property Taxes-Levy Year	2	0	0		0	0			0	0	0
Net Current Property Taxes	3	22,674,292	1,501,289		14,857,631	0			39,033,212	37,688,585	34,696,216
Delinquent Property Taxes	4	3,000	0		2,000	0			5,000	5,000	0
TIF Revenues	5			4,077,651					4,077,651	3,603,844	3,531,215
Other City Taxes	6	8,525,833	29,827		331,722	3,240,000			12,127,382	11,811,007	11,782,554
Licenses & Permits	7	1,230,750	0					207,500	1,438,250	1,578,250	1,559,903
Use of Money and Property	8	442,010	95,510	0	100,000	382,750	0	599,765	1,620,035	1,869,338	3,466,547
Intergovernmental	9	1,639,830	5,933,162	0	257,967	3,075,000		1,134,097	12,040,056	10,269,204	18,169,740
Charges for Fees & Service	10	1,239,000	0		0	0	0	29,033,237	30,272,237	28,993,807	32,093,364
Special Assessments	11	11,500	0		0	2,000		0	13,500	13,500	13,737
Miscellaneous	12	521,320	122,000		0	83,000	0	2,826,300	3,552,620	4,687,897	1,593,571
Sub-Total Revenues	13	36,287,535	7,681,788	4,077,651	15,549,320	6,782,750	0	33,800,899	104,179,943	100,520,432	106,906,847
Other Financing Sources:											
Total Transfers In	14	1,436,747	174,331	0	45,451	3,300,000	0	2,186,027	7,142,556	9,615,239	12,811,183
Proceeds of Debt	15	0	0	0	0	11,600,000		0	11,600,000	16,700,000	17,412,175
Proceeds of Capital Asset Sales	16	0	0	0	0	75,000	0	0	75,000	75,000	207,981
Total Revenues and Other Sources	17	37,724,282	7,856,119	4,077,651	15,594,771	21,757,750	0	35,986,926	122,997,499	126,910,671	137,338,186
Expenditures & Other Financing Uses											
Public Safety	18	18,111,678	46,000	0			0		18,157,678	17,579,807	15,754,715
Public Works	19	0	4,467,716	0			0		4,467,716	4,269,833	3,858,148
Health and Social Services	20	0	0	0			0		0	0	0
Culture and Recreation	21	7,291,299	73,900	0			0		7,365,199	7,059,241	6,124,349
Community and Economic Development	22	2,227,422	25,000	3,791,041			0		6,043,463	5,427,518	7,652,889
General Government	23	6,502,343	0	0			0		6,502,343	6,265,972	5,331,003
Debt Service	24	2,500	0	474,190	16,365,770		0		16,842,460	15,600,087	15,624,463
Capital Projects	25	528,886	2,713,725	0		29,196,802	0		32,439,413	26,045,584	23,300,162
Total Government Activities Expenditures	26	34,664,128	7,326,341	4,265,231	16,365,770	29,196,802	0		91,818,272	82,248,042	77,645,729
Business Type Proprietary: Enterprise & ISF	27							33,479,148	33,479,148	32,107,629	28,668,471
Total Gov & Bus Type Expenditures	28	34,664,128	7,326,341	4,265,231	16,365,770	29,196,802	0	33,479,148	125,297,420	114,355,671	106,314,200
Total Transfers Out	29	2,228,527	1,411,529	0	0	3,352,500	0	150,000	7,142,556	9,615,239	12,811,183
Total ALL Expenditures/Fund Transfers Out	30	36,892,655	8,737,870	4,265,231	16,365,770	32,549,302	0	33,629,148	132,439,976	123,970,910	119,125,383
Excess Revenues & Other Sources Over	31										
(Under) Expenditures/Transfers Out	32	831,627	-881,751	-187,580	-770,999	-10,791,552	0	2,357,778	-9,442,477	2,939,761	18,212,803
Beginning Fund Balance July 1	33	18,061,131	4,431,127	548,624	996,804	22,601,323	0	101,328,289	147,967,298	145,027,537	126,814,734
Ending Fund Balance June 30	34	18,892,758	3,549,376	361,044	225,805	11,809,771	0	103,686,067	138,524,821	147,967,298	145,027,537

LONG TERM DEBT SCHEDULE - LT DEBT1

GENERAL OBLIGATION BONDS, TIF BONDS, REVENUE BONDS, LOANS, LEASE-PURCHASE PAYMENTS

Debt Name		Amount of Issue	Type of Debt Obligation	Debt Resolution Number	Principal Due FY	Interest Due FY	Total Obligation Due FY	Bond Reg./ Paying Agent Fees Due FY	Reductions due to Refinancing or Prepayment of Certified Debt	Paid from Funds OTHER THAN Current Year Debt Service Taxes	Amount Paid Current Year Debt Service Levy
6/1/12 GO	1	11,340,000	GO	1488-10	650,000	129,063	779,063			451,199	327,864
6/1/13 GO	2	9,985,000	GO	84A-13	560,000	130,350	690,350				690,350
6/1/13 GO	3	700,000	GO	84A-13	40,000	9,113	49,113				49,113
6/1/13 Stormwater	4	1,500,000	NON-GO	84A-13	85,000	19,600	104,600			104,600	0
6/1/13 Sewer	5	1,500,000	NON-GO	84A-13	85,000	19,600	104,600			104,600	0
12/30/15 GO	6	8,885,000	GO	320-15	515,000	174,161	689,161				689,161
12/30/15 GO Downtown	7	700,000	GO	322-15	40,000	11,944	51,944				51,944
12/30/15 GO Refunding	8	2,545,000	GO	322-15	340,000	17,000	357,000				357,000
12/30/15 GO Refunding	9	4,590,000	GO	322-15	685,000	34,250	719,250			719,250	0
12/30/15 Sewer Refunding	10	1,220,000	NON-GO	322-15	180,000	9,000	189,000			189,000	0
12/30/15 Stormwater Refunding	11	1,225,000	NON-GO	322-15	185,000	9,250	194,250			194,250	0
3/1/16 Stormwater	12	2,030,000	NON-GO	343-16	115,000	37,260	152,260			152,260	0
3/1/16 Sewer	13	2,030,000	NON-GO	343-16	115,000	37,260	152,260			152,260	0
12/1/16 GO	14	8,945,000	GO	385-16	455,000	168,481	623,481				623,481
12/1/16 FG Park	15	700,000	GO	385-16	35,000	13,200	48,200				48,200
12/1/16 Various Projects	16	700,000	GO	385-16	35,000	13,200	48,200				48,200
12/1/16 Downtown ph. IV & V	17	1,400,000	GO	385-16	70,000	28,740	98,740				98,740
6/28/17 BettPlex Improvements	18	3,180,000	GO	226-17	160,000	53,625	213,625				213,625
6/28/17 BettPlex UR Annual Appropriation	19	2,195,000	GO	228-17	120,000	49,413	169,413				169,413
7/15/17 BettPlex TIF Annual Appropriation	20	4,900,000	NON-GO	224-17	224,903	249,287	474,190			474,190	0
12/28/17 GO	21	10,350,000	GO	420-17	505,000	252,319	757,319				757,319
12/14/17 Stormwater	22	2,030,000	NON-GO	408-17	100,000	48,655	148,655			148,655	0
12/14/17 Sewer	23	4,045,000	NON-GO	407-17	195,000	96,940	291,940			291,940	0
12/28/17 Refunding	24	5,685,000	GO	425-17	700,000	104,050	804,050				804,050
12/28/17 Refunding	25	390,000	GO	425-17	50,000	7,200	57,200				57,200
12/28/17 Refunding	26	390,000	GO	425-17	50,000	7,200	57,200				57,200
12/28/17 Refunding	27	370,000	GO	425-17	40,000	7,600	47,600				47,600
12/28/17 Refunding	28	7,320,000	GO	425-17	780,000	150,200	930,200				930,200
12/28/17 Stormwater Refunding	29	1,350,000	NON-GO	425-17	145,000	27,750	172,750			172,750	0
12/28/17 Refunding	30	8,460,000	GO	425-17	935,000	223,550	1,158,550				1,158,550
TOTALS					8,194,903	2,139,261	10,334,164	0	0	3,154,954	7,179,210

LONG TERM DEBT SCHEDULE - LT DEBT2

GENERAL OBLIGATION BONDS, TIF BONDS, REVENUE BONDS, LOANS, LEASE-PURCHASE PAYMENTS

Debt Name		Amount of Issue	Type of Debt Obligation	Debt Resolution Number	Principal Due FY	Interest Due FY	Total Obligation Due FY	Bond Reg./ Paying Agent Fees Due FY	Reductions due to Refinancing or Prepayment of Certified Debt	Paid from Funds OTHER THAN Current Year Debt Service Taxes	Amount Paid Current Year Debt Service Levy
12/28/17 Sewer Refunding	31	1,150,000	NON-GO	425-17	115,000	27,950	142,950			142,950	0
12/4/18 GO	32	9,105,000	GO	389-18	440,000	304,850	744,850				744,850
12/4/18 FG Park	33	1,830,000	GO	389-18	85,000	57,650	142,650				142,650
1/7/20 GO	34	8,880,000	GO	379-19	425,000	231,488	656,488				656,488
1/7/20 GO Downtown	35	700,000	GO	379-19	30,000	17,256	47,256				47,256
1/7/20 GO Palmer Hills	36	700,000	GO	379-19	30,000	17,256	47,256				47,256
3/1/20 Stormwater	37	2,030,000	NON-GO	22-20	95,000	51,233	146,233			146,233	0
3/1/20 Sewer	38	2,030,000	NON-GO	20-20	90,000	57,750	147,750			147,750	0
9/23/20 Refunding	39	15,065,000	GO	259-20	1,340,000	131,700	1,471,700				1,471,700
10/30/20 SRF Loan	40	445,000	GO	288-20	11,000	3,720	14,720				14,720
12/17/20 GO	41	8,290,000	GO	360-20	365,000	196,500	561,500				561,500
3/1/22 GO	42	10,195,000	GO	79-22	405,000	342,970	747,970				747,970
3/1/22 UR Annual Appropriation	43	2,915,000	GO	79-22	115,000	98,120	213,120				213,120
3/1/22 Palmer Hills	44	700,000	GO	79-22	30,000	23,630	53,630				53,630
3/1/22 UR Annual Appropriation	45	3,095,000	GO	81-22	130,000	80,540	210,540				210,540
3/1/22 Sewer	46	2,425,000	NON-GO	79-22	95,000	81,400	176,400			176,400	0
3/1/23 GO	47	13,280,000	GO	29-23	500,000	532,331	1,032,331				1,032,331
3/1/24 GO	48	11,205,000	GO	67-24	95,000	512,850	607,850				607,850
3/1/24 UR GO	49	2,400,000	GO	67-24	85,000	105,850	190,850				190,850
3/1/24 Storm	50	2,010,000	NON-GO	67-24	70,000	88,700	158,700			158,700	0
12/13/24 Sewer SRF	51	9,500,000	NON-GO	340-24	365,000	179,285	544,285			544,285	0
3/1/25 GO	52	10,090,000	GO	47-25	255,000	551,848	806,848				806,848
3/1/25 UR GO	53	5,655,000	GO	47-25	145,000	309,284	454,284				454,284
	54	-	-				0				0
	55	-	-				0				0
	56	-	-				0				0
	57	-	-				0				0
	58	-	-				0				0
	59	-	-				0				0
	60	-	-				0				0
TOTALS					13,510,903	6,143,422	19,654,325	0	0	4,471,272	15,183,053

LONG TERM DEBT SCHEDULE - GRAND TOTALS**GENERAL OBLIGATION BONDS, TIF BONDS, REVENUE BONDS, LOANS, LEASE-PURCHASE PAYMENTS**

	Principal Due FY 2026	Interest Due FY 2026	Total Obligation Due FY 2026	Bond Reg./ Paying Agent Fees Due FY 2026	Reductions due to Refinancing or Prepayment of Certified Debt	Paid from Sources OTHER THAN Budget Year Debt Service Levy	Amount Paid Budget Year Debt Service Levy
GO - TOTAL	11,251,000	5,102,502	16,353,502	0	0	1,170,449	15,183,053
NON GO - TOTAL	2,259,903	1,040,920	3,300,823	0	0	3,300,823	0
GRAND - TOTAL	13,510,903	6,143,422	19,654,325	0	0	4,471,272	15,183,053

FY 25/26 Budget



FY 25/26 Budget Highlights

- \$113 million net of internal funds and transfers
- Continues to demonstrate the City's financial strength & flexibility
- Funds current service levels across all departments despite rising costs and no increase in the levy rate
- Upholds the City's commitment to fully funding six firefighters currently paid for by the SAFER grant
- Remains aggressive on infrastructure improvements such as streets and sewers
- Funds the purchase of \$6 million in overdue vehicle replacements delayed by supply chain issues – many ordered more than 3 years ago!

Prices on the Rise

- Labor Contracts – Year 2 of 4-year contracts with bargaining units
 - AFSCME & Non-Union, 3.5%; PD, 3.75%; FD, 3.20%
- Liability Insurance – 55% higher than four years ago
- Health Insurance – FY26 8% higher than FY25
 - Up 38% since FY22
 - Employee contributions and other revenue increased by 54% in last 4-years
- Vehicles and Equipment – Exceeding 10% increases annually

Vehicle	Purchase Price	Replacement Price	% Increase
2005 Alexis Rescue	343,584	911,976	165%
2019 Toro Mower	52,587	90,000	71%
2016 Ford F-250	32,644	70,000	114%
2012 Ford F-550	54,451	135,000	148%
2010 Single Axle Dump	89,752	250,788	179%

Efficiency Initiatives

• Community Development

- 100% FEMA Flood Buyout Grant
- **Interns/Seasonal Staff**
- **HDC plans scanning project**
- Near zero overtime

• Culture & Recreation

- Combined or left positions vacant & cross trained staff
- **Family Museum closed on Sunday**
- Increased sponsorships
- Increased fees
- Eliminated LFC operations
- Eliminated Splash operations
- Renegotiated contracts for tennis and youth baseball
- Eliminated overtime
- Contracted Palmer Grill
- In-house equipment maintenance
- **Native “no-mow” areas**
- **Reduced chemical application**

• Legal

- Minimize outside counsel expenses
- **Virtual continuing legal education**
- Process/efficiencies analysis

- Elimination of IT hardware

• Library

- Reduced management positions
- **Reduced Sunday & evening hours**
- Reduced paper mailings

• Finance

- Purchasing consortiums
- Office supplies consolidation
- **Web based training**
- NetSuite for Government ERP
- **1-to-1 devices**
- Reduced paper/print

• Fire

- SAFER Grant
- Port Security Grant
- In-house maintenance
- **Automatic Aid Agreements**

• Human Resources

- Stop loss carrier to ATS
- **Rx Elixer to Wellmark**
- \$0 deductible work-comp ins.
- **Wellness Committee**
- Safety program/ICAP Grant

• Police

- Reduced overtime
- Use of grants and drug seizure funds for equipment purchases
- Reduced range maintenance
- **Repurposing rifle lowers**

• Public Works

- **Liquid snow/ice control**
- **Mid-mount wing plows**
- Pavement Management System
- Grant funded projects
- Right sizing of transit program
- **LED lighting and rebates**
- **Waterfront Lighting Project**
- Plow truck rehabilitation
- WWTP equalization basin avoided

Lean Operating Budget

*Assumptions: Bettendorf mean home value of \$321,952
 65 gallon or comparable garbage cart, sewer usage of 7.33 units per month (733 cu. ft.), and a Storm Water ERU of 1.00. For cities using private solid waste collection, the cost above reflects rates provided by private haulers.
 --Prepared by Bettendorf finance staff with FY 24/25 tax levies and service fees from city websites and billing departments as of 12/31/24.

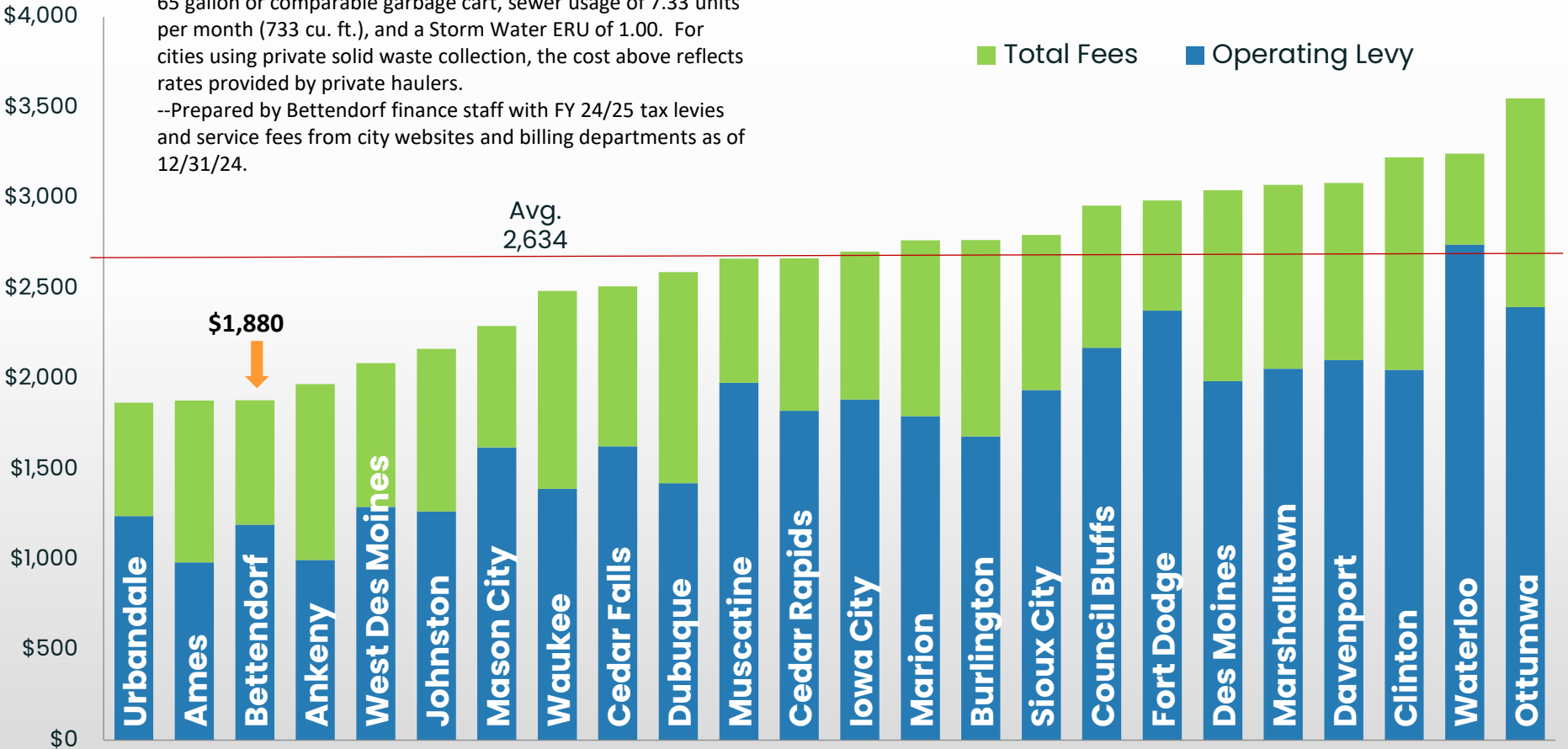

Total Levy Rate Held at \$13.11

- HF718 limits growth in property tax revenue by automatically reducing the General Fund levy rate by a tiered growth limitation factor
 - General Fund levy rate reduced from 7.65 to 7.57 for FY 25/26
 - Equal to about \$225,000 in property tax revenue
- As the limitation factor reduces the General Fund levy rate, the City can utilize other available levy rates to fill the gap
- In FY26 there is capacity for about \$2.14/1,000. Equivalent to \$6.3 million in unlevied property taxes.

	FY 24/25	FY 25/26
General Fund*	\$7.65	\$7.57
Health Insurance	0.13	0.13
Liability Insurance	0.05	0.10
Police & Fire Pension	0.31	0.32
Transit	0.12	0.14
Debt Service	\$4.85	\$4.85
Total	\$13.11	\$13.11

Property Tax Impact

Residential: Average existing value unchanged, Rollback up to 47.43% of assessed value from 46.34%, City Levy remains \$13.11/1000

2024 Mean Assessed Value	Impact of change in assessed value	Impact of change in rollback	Impact of change in levy rate	Total impact on FY 25/26 property taxes
\$321,952	+\$0	+\$46	+\$0	+\$46 (2.4%)

Commercial: Average existing value unchanged, Rollback remains 90% of assessed value, but 1st \$150K rolled back to residential, City Levy remains \$13.11

2024 Mean Assessed Value	Impact of change in assessed value	Impact of change in rollback	Impact of change in levy rate	Total impact on FY 24/25 property taxes
\$1,277,410	+\$0	+\$21	+\$0	+\$21 (>1%)

Property Tax Estimate

[HOME](#) > [GOVERNMENT](#) > [MAYOR & COUNCIL](#) > [WARD & ADDRESS INFORMATION](#)

Alderman, Ward & Address Information

Enter your address to find your information for your property address. Search results will show Voting Information, School Zone Information, and Ward Information.

Search by address. Do not enter the street suffix (ave, st, etc...)

For Garbage and Recycling pickup information, please click on the button below.



Property Tax Estimate

Property Tax Estimation (City Taxes Only)

The tax calculations below are estimations of City of Bettendorf taxes for your address. The calculations do not include estimates for other taxing entities such as the county or school districts. The estimations also do not account for any credits which may or may not be applicable to your parcel. This is an estimation only. Your actual property tax bill may differ.

Current Year FY 2024/25 with \$13.11 Levy Rate: \$2343.33

Budget Year FY 2025/26 with \$13.11 Levy Rate: \$2398.40

For property details and tax valuations, please visit the [Scott County parcel search website](#). The City of Bettendorf assumes no liability for the data generated by this estimator and assumes no liability for any user's usage of or reliance on it. Use of this estimator and the data generated constitutes acceptance of this disclaimer. The data generated by this estimator may not be applicable or accurate with regard to your individual circumstances and cannot be relied upon to avoid penalties on taxes owed.

Impact of Taxes & Fees

	Residential @ <u>13.11</u> Mean Value: \$321,952 (Rollback increased to 47.4316%)	Small Business @ <u>13.11</u> Mean Value: \$1,277,410 (Rollback remains at 90%, 1st 150,000 @ 47.4316%)
City's Portion of Property Tax	\$45.96	\$21.41
Sewer Fees	\$19.36	\$50.16
\$4.27 per unit (\$0.22 increase)	(22 units/quarter)	(57 units/quarter)
Storm Water Fees	\$1.20	\$14.82
\$5.90 per ERU (\$0.10 increase)	(1.00 ERU/month)	(12.35 ERU/month)
Solid Waste Fees	\$4.44	NA
\$18.88 per month (2% increase)		
(Based on 65 gal. Cart)		
Total Increase	\$70.96 (+\$5.91 per Month)	\$86.39 (+\$7.20 per month)
Total Annual Cost of Services	\$2,667	\$16,119

FY 24/25 Comparison of Property Taxes & User Fees for Average Residential Property

Includes 24 Iowa cities with populations of 23,000 or more

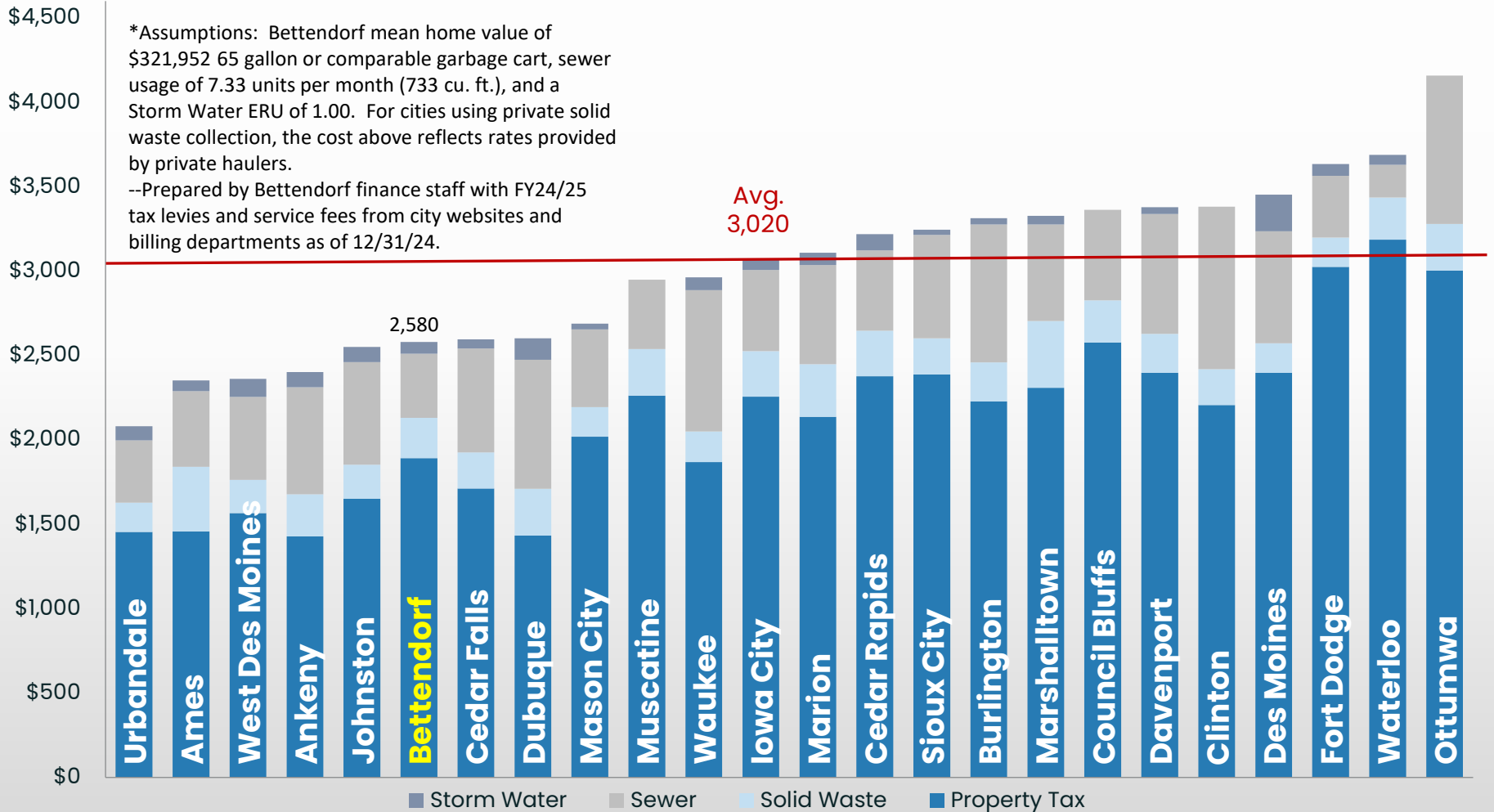

Budget Calendar

2/10-2/14/25	Informational Meetings – Budget Highlights
2/18/25	Budget Workshop – 5:00 prior to COW & Council
3/3/25	Budget Workshop – Following COW
3/5/25	Taxpayer Statement Data to DOM
3/17/25	Budget Workshop (<i>if necessary</i>) – Following COW
3/18/25	Set the Date for 1 st Public Hearing
4/1/25	1 st Public Hearing – Special Meeting Prior to Council Set the Date for 2 nd Public Hearing
4/15/25	2 nd Public Hearing and Adoption of the Budget

COUNCIL LETTER

MEETING DATE: April 15, 2025

REQUESTED BY: Austin Whelan, Transit Operations Manager



Item Title

Public hearing for the FY2026 application for State Transit Assistance funds for Transit System Operations.

Resolution approving the FY2026 application for State Transit Assistance funds for Transit System Operations.

Explanation

Each year, State Transit Assistance funds are available to the City of Bettendorf to support transit system operations. A grant application must be submitted in order to obtain this funding. The FY2026 State funding allocation for Bettendorf is estimated to be \$258,355.00 and the grant period will begin on July 1, 2025. These funds help the City continue providing a quality, responsive transit service to the Citizens of Bettendorf.

The State requires a public hearing be held to allow persons the opportunity to speak in favor of, or in opposition to the grant application. The public hearing was scheduled and notice was provided twenty-eight (28) days prior to the City Council Meeting this 15th day of April, 2025 at Bettendorf City Hall. All public comments are to be considered prior to approval and submittal of the FY2026 grant application.

If the matter is not budgeted in the current year, explain why funding is requested and the anticipated source:

List Attachments

Resolution, Authorizing STA Resolution.

RESOLUTION NO: _____ -25

**RESOLUTION APPROVING THE FY2026 APPLICATION FOR STATE TRANSIT ASSISTANCE FUNDS FOR
TRANSIT SYSTEM OPERATIONS**

WHEREAS, the State of Iowa Office of Public Transit requires a public hearing to allow persons the opportunity to speak in favor of, or in opposition to, the submission of a grant; and

WHEREAS, a public hearing on the FY2026 application for State Transit Assistance funds was held in the Council Chambers of Bettendorf City Hall, 1609 State Street, Bettendorf, Iowa at 7 o'clock PM on the 15th day of April, 2025: and

WHEREAS, all public comments have been considered at a regular meeting of the City Council.

NOW, THEREFORE BE IT RESOLVED BY THE CITY COUNCIL OF THE CITY OF BETTENDORF, IOWA, that the FY2026 application for State Transit Assistance funds in the estimated amount of \$258,355.00 to be used by the City's transit system for transit system operations be approved.

Passed, Approved, and Adopted this 15th day of April 2025.

Robert S. Gallagher, Mayor

Attest:

Decker P. Ploehn, City Clerk

Authorizing Resolution

We, hereby, authorize Mr. Robert Gallagher
(Name of Authorized Signatory)

on behalf of City of Bettendorf
(Legal Name of Applicant)

to apply for financial assistance as noted below and to enter into related contract(s) with the Iowa Department of Transportation.

From the State Transit Assistance Program:

1.33533657 % of formula funds;
\$ _____ of Special Project funds

From federal funds for transit in non-urbanized areas and/or for transit serving primarily elderly persons and person with disabilities:

\$ _____

From statewide federal capital assistance for transit:

\$ _____

We understand acceptance of federal transit assistance involves an agreement to comply with certain labor protection provisions.

We certify that City of Bettendorf
(Legal Name of Applicant)

has sufficient non-federal funds to provide required local match for capital projects and at time of delivery will have the funds to operate and maintain vehicles and equipment purchased under this project.

We request that State Transit Assistance formula funding be advanced as allowed by law, to improve transit system cash flow.

Adopted the 15th day of April, 2025

Name: City of Bettendorf
(Applicant's Governing Body)

By: _____
(Signature of Chief Executive Officer) (Printed Name of Chief Executive Officer)

Title: Mayor, City of Bettendorf

Address: 1609 State St Bettendorf, IA 52722

Telephone: 563-344-4013 E-mail Address: bgallagher@bettendorf.org
(E-mail Address of Chief Executive Officer)

COUNCIL LETTER

MEETING DATE: April 15, 2025
REQUESTED BY: Pat Lynch, P.E., Assistant City Engineer



Item Title

Public hearing for the 2025 Full Depth Patching Program.

Resolution approving the plans, specifications and form of contract for the 2025 Full Depth Patching Program.

Explanation

The proposed improvements consist of full-depth concrete patching, utility structure repairs and adjustments, and other work associated with the replacement of approximately 6,400 square yards of existing pavement along various streets within the City of Bettendorf, Iowa.

Relationship to Goals: Upgraded City Infrastructure & Public Facilities.

If the matter is not budgeted in the current year, explain why funding is requested and the anticipated source:

The overall project (PW0598, RU0045, & RU0046) was approved with a total budget of \$1,000,000 within the Community Improvement Program (CIP).

List Attachments

Resolution; Plans and Specifications (on file in the office of the City Engineer).

RESOLUTION NO. _____-25

**RESOLUTION APPROVING THE PLANS, SPECIFICATIONS, AND FORM OF CONTRACT FOR THE
2025 FULL DEPTH PATCHING PROGRAM**

WHEREAS, plans, specifications, notice to bidders and form of contract are on file in the office of the City Engineer for construction of certain improvements to the street system of said city; namely the

2025 Full Depth Patching Program

WHEREAS, notice of hearing on the specifications, and form of contract was published as required by law, and

WHEREAS, a public hearing on the plans, specifications, and form of contract was held in the City Hall Council Chambers, 1609 State Street, Bettendorf, Iowa, at 7:00 o'clock p.m. on the 15th day of April, 2025,

NOW, THEREFORE BE IT RESOLVED BY THE CITY COUNCIL OF THE CITY OF BETTENDORF, IOWA, that the plans, specifications, and form of contract be approved and adopted as the plans, specifications, and form of contract for said improvements.

Passed, Approved and Adopted this 15th day of April 2025.

Robert S. Gallagher, Mayor

Attest:

Decker P. Ploehn, City Clerk

COUNCIL LETTER

MEETING DATE: April 15, 2025
REQUESTED BY: Pat Lynch, P.E., Assistant City Engineer



Item Title

Public hearing for the Devils Glen Road over Duck Creek – Bridge Approach and Joint Replacement Project.

Resolution approving the plans, specifications and form of contract for the Devils Glen Road Over Duck Creek – Bridge Approach and Joint Replacement Project.

Explanation

The proposed improvements consist of removal and replacement of the bridge approach pavement, partial removal and replacement of a barrier wall, and removal and replacement of the bridge expansion joints.

Relationship to Goals: Upgraded City Infrastructure & Public Facilities.

If the matter is not budgeted in the current year, explain why funding is requested and the anticipated source:

This project (PW0587/PW0588) was approved with a total budget of \$400,000.00 within the Community Improvement Program (CIP). Please note that this purchase order is one of several that will be bid and issued under this project number and associated budget. The current budget summary is as follows:

Total CIP Budget	\$400,000.00
POs Issued to Date	<u>\$ 50,000.00</u>
Remaining Budget	\$350,000.00

List Attachments

Resolution; Plans and Specifications (on file in the office of the City Engineer).

RESOLUTION NO. _____-25

**RESOLUTION APPROVING THE PLANS, SPECIFICATIONS, AND FORM OF CONTRACT
FOR THE DEVILS GLEN ROAD OVER DUCK CREEK – BRIDGE APPROACH
AND JOINT REPLACEMENT PROJECT**

WHEREAS, plans, specifications, notice to bidders and form of contract are on file in the office of the City Engineer for construction of certain improvements to the street system of said city; namely the

Devils Glen Road over Duck Creek -Bridge Approach and Joint Replacement Project

WHEREAS, notice of hearing on the specifications, and form of contract was published as required by law, and

WHEREAS, a public hearing on the plans, specifications, and form of contract was held in the City Hall Council Chambers, 1609 State Street, Bettendorf, Iowa, at 7:00 o'clock p.m. on the 15th day of April, 2025,

NOW, THEREFORE BE IT RESOLVED BY THE CITY COUNCIL OF THE CITY OF BETTENDORF, IOWA, that the plans, specifications, and form of contract be approved and adopted as the plans, specifications, and form of contract for said improvements.

Passed, Approved and Adopted this 15th day of April 2025.

Robert S. Gallagher, Mayor

Attest:

Decker P. Ploehn, City Clerk

COUNCIL LETTER

MEETING DATE: April 1, 2025 (SPH)
April 15, 2025 (HPH)
REQUESTED BY: Mark Hunt
Community Development Director



Item Title

Resolution setting a date for public hearing on an ordinance amending Title 11, Chapter 14 – Sign Ordinance, Section 11-4-3(F) General Requirements and Restrictions – Public Service and Safety Signs and Section 11-4-8(B) Billboard Signs (Off-Premises Advertising) – Location. (Case 25-004-ORD) (4/1/25)

Public hearing and first reading of an ordinance amending Title 11, Chapter 14 – Sign Ordinance, Section 11-4-3(F) General Requirements and Restrictions – Public Service and Safety Signs and Section 11-4-8(B) Billboard Signs (Off-Premises Advertising) – Location. (Case 25-004-ORD) (4/15/25)

Explanation

Staff is proposing to amend sections of Title 11: Chapter 14 Sign Ordinance for the following purposes:

- Clean up language and better define “official sign” categories.
- Allow Bettendorf Light Pole Banner Program Signs.
- Add the I-80 Urban Renewal Area as a billboard sign exclusion location.

The Bettendorf Light Pole Banner Program Signs are signs located on publicly owned light poles located in the right-of-way which contain the City of Bettendorf logo and a sponsor logo. All banners shall follow administrative policy and guidelines, which in summary, allow potential sponsors to apply for a banner if the portion of the banner is used only for displaying sponsor name/logo and not for advertising.

Amendments to the allowable locations for billboard signs are being proposed. In addition to specific zoning districts, certain buffer areas, and the Downtown Master Plan Overlay District prohibiting new billboard sign (static) or new/converted billboard sign (digital display), the I-80 Urban Renewal Area is also being added to prohibited locations. This amendment is in response to one of the City’s top priorities in the 2024-2025 Strategic Plan, which is to develop and approve an I-80/Middle Road Overlay District. A billboard sign prohibition was one item to be included in the proposed district. Master planning for the overlay district will be conducted later this year and will also consider future visioning, character design, and other development variables.

The Planning and Zoning Commission made a recommendation for approval of the ordinance amendments at their March 19, 2025 meeting.

If the matter is not budgeted in the current year, explain why funding is requested and the anticipated source:

N/A

List attachments

Resolution; Ordinance; (A) Staff Report with attachments; (B) Planning and Zoning Commission report to Mayor and City Council; (C) Excerpts from the Planning and Zoning Commission meeting minutes regarding this matter.

RESOLUTION NO. ____ - 25

**RESOLUTION SETTING A DATE FOR PUBLIC HEARING
ON AN ORDINANCE AMENDING TITLE 11, CHAPTER 14 – SIGN ORDINANCE
SECTION 11-4-3(F) GENERAL REQUIREMENTS AND RESTRICTIONS –
PUBLIC SERVICE AND SAFETY SIGNS AND
SECTION 11-4-8(B) BILLBOARD SIGNS (OFF-PREMISES ADVERTISING) – LOCATION
OF THE BETTENDORF CITY CODE**

BE IT RESOLVED BY THE CITY COUNCIL OF THE CITY OF BETTENDORF, IOWA, that a date for public hearing be set for April 15, 2025 at 7:00 p.m., City Hall Council Chambers, 1609 State Street on the matter of an ordinance amending Title 11, Chapter 14 of the Bettendorf City Code – Sign Ordinance, Sections 11-4-3(F) General Requirements and Restrictions – Public Service and Safety Signs and Section 11-4-8(B) Billboard Signs (Off-Premises Advertising) - Location.

PASSED, APPROVED, AND ADOPTED this 1st day of April, 2025.

Robert S. Gallagher, Mayor

ATTEST:

Decker P. Ploehn, City Clerk

Return to: Michelle Spencer, Bettendorf City Hall, 1609 State Street, Bettendorf, IA 52722

ORDINANCE NO. _____ - 25

**ORDINANCE AMENDING TITLE 11, CHAPTER 14 – SIGN ORDINANCE
SECTION 11-4-3(F) GENERAL REQUIREMENTS AND RESTRICTIONS AND
SECTION 11-4-8(B) BILLBOARD SIGNS (OFF-PREMISES ADVERTISING)
OF THE BETTENDORF CITY CODE**

Section 1. BE IT ENACTED BY THE CITY COUNCIL OF THE CITY OF BETTENDORF, IOWA, that Title 11, Chapter 14 of the Bettendorf City Code – Sign Ordinance, Section 11-14-3(F) General Requirements and Restrictions – Public Service and Safety Signs is hereby deleted and the following substituted therefor:

F. Signs on Public Property and Rights-of-Way: No signs other than official signs shall be permitted on public property or rights-of-way. Only signs that have been placed by or authorized by a federal, state, or local agency may be installed on public property or rights-of-way. Any sign installed on public property without prior authorization, including rights-of-way, will be removed by the City without notice and disposed of.

1. Official Sign Categories:

- a. Public Safety Signs: Traffic signs, directional signage, and construction signage.
- b. Legal/Public Notice Signs: Any public notice or warning required by applicable Federal, State or local law, regulation, or ordinance.
- c. Public Utilities: Warning signs, informational signs, notices, or markers which are customarily erected and maintained by publicly owned or privately-owned public utilities.
- d. Bettendorf Light Pole Banner Program Signs: A banner affixed to a city-owned light pole. All banners shall meet the Bettendorf Light Pole Banner Program policy and guidelines.

Section 2. BE IT ENACTED BY THE CITY COUNCIL OF THE CITY OF BETTENDORF, IOWA, that Title 11, Chapter 14 of the Bettendorf City Code – Sign Ordinance, Section 11-14-8(B) Billboard Signs (Off-Premises Advertising) - Location is hereby amended by adding the following thereto:

3. I-80 Urban Renewal Plan Area Exclusion: Regardless of the underlying zoning district, no billboard signs (static) and no billboard signs (digital display) shall be permitted in the I-80 Urban Renewal Plan Area. Said area is described in Resolution 85-17.

Section 3. Severability of Provisions. If any subsection, sentence, clause, phrase, or portion of this ordinance be held invalid or unconstitutional by any court of competent jurisdiction, such portion shall be deemed a separate, distinct and independent provision, and such holding shall not affect the validity of the remaining portion hereof.

Section 4. Full Force and Effect. This ordinance shall be in full force and effect from the date of passage and publications as required by law.

Section 5. Repealer. This ordinance shall be construed to repeal any prior ordinance inconsistent herewith.

PASSED, APPROVED, AND ADOPTED this _____ day of _____, 2025.

Robert S. Gallagher, Mayor

ATTEST:

Decker P. Ploehn, City Clerk



Staff Report

Subject: Planning & Zoning Commission
Author: Taylor Beswick
Department: Community Development
Date: March 14, 2025

Case No.: 25-004-ORD
Request: Amend sections of 11-14: Sign Ordinance
Location: City-wide
Applicant: Community Development & Economic Development Staff
Summary: Amends Sign Ordinance to improve definitions for public right-of-way signs, allow public banners on city-owned light poles, and adds I-80 Urban Renewal Area as a billboard exclusion location.

Background Information, Facts, and Staff Analysis

Staff is proposing to amend sections of Title 11: Chapter 14 Sign Ordinance for the following purposes:

- Cleanup language and better define “official sign” categories.
- Allow Bettendorf Light Pole Banner Program Signs.
- Adds the I-80 Urban Renewal Area as a billboard sign exclusion location.

Attachment A contains the redline amendments to 11-14-3(F.) and 11-14-8(B.).

The Bettendorf Light Pole Banner Program Signs are signs are located on publicly owned light poles located in the right-of-way which contain The City of Bettendorf logo and a sponsor logo (see Banner Example – Attachment B). All banners shall follow administrative policy and guidelines, which in summary, allows potential sponsors to apply for a banner if the portion of the banner is used only for displaying sponsor name/logo and not for advertising.

Amendments to the allowable locations for billboard signs are being proposed. In addition to specific zoning districts, certain buffer areas, and the Downtown Master Plan Overlay District prohibiting new billboard sign (static) or new/converted billboard sign (digital display), the I-80 Urban Renewal Area is also being added to prohibited locations. This amendment is in response to one of the City’s top priorities in the 2024-2025 Strategic Plan, which is to develop and approve an I-80/Middle Road Overlay District (see I-80 Urban Renewal Area Map – Attachment C). A billboard sign prohibition was one item to be included in the proposed district. Master planning for the overlay district will be conducted later this year and will also consider future visioning, character design, and other development variables.

Staff Recommendation

Staff contends the proposed amendments enhance the City of Bettendorf's character and promote placemaking, all goals outlined in the City's Comprehensive Plan. Staff recommends approval of Case 25-004-ORD, Zoning Ordinance amendments to section 11-14-3(F.) and 11-14-8(B.).

Respectfully submitted,

Taylor Beswick
Senior City Planner

TITLE 11
CHAPTER 14
SIGN ORDINANCE

11-14-3: GENERAL REQUIREMENTS AND RESTRICTIONS

~~F. Signs on Public Property and Rights-of-Way: No signs other than official signs shall be permitted on public property or rights-of-way. Only signs that have been placed by or authorized by a federal, state, or local agency may be installed on public property or rights-of-way. Any sign installed on public property without prior authorization, including rights-of-way, will be removed by the City without notice and disposed of. Public Service And Safety Signs: No signs other than public service and safety signs shall be permitted on public property unless authorized by the governmental agency having control thereof.~~

1. Official Sign Categories:

- a. Public Safety Signs: Traffic signs, directional signage, and construction signage.
- b. Legal/Public Notice Signs: Any public notice or warning required by applicable Federal, State or local law, regulation or ordinance.
- c. Public Utilities: Warning signs, informational signs, notices, or markers which are customarily erected and maintained by publicly owned or privately-owned public utilities.
- d. Bettendorf Light Pole Banner Program Signs: A banner affixed to a city-owned light pole. All banners shall meet the Bettendorf Light Pole Banner Program policy and guidelines.

11-14-8: BILLBOARD SIGNS (OFF-PREMISES ADVERTISING)

B. Location:

1. Permitted Districts: Billboard signs are permitted in I-1, I-2, I-3, C-3, C-6, C-7 Zoning Districts. Billboard signs are also permitted in the C-2 zoning district if within six hundred sixty feet (660') of a U.S. highway or interstate right-of-way.

2. Downtown Master Plan Overlay District Exclusion: Regardless of the underlying zoning district, no billboard signs shall be permitted in the Downtown Master Plan Overlay District, nor any other overlay district that does not allow billboard signs.

3. I-80 Urban Renewal Plan Area Exclusion: Regardless of the underlying zoning district, no billboard signs (static) and no billboard signs (digital display) shall be permitted in the I-80 Urban Renewal Plan Area. Said area is described in Resolution 85-17.

Below is the proposed City Design for your banner project.
Please note that the colors of the printed banners may vary from those shown in the proof due to the banner material.



I-80 Urban Renewal Area

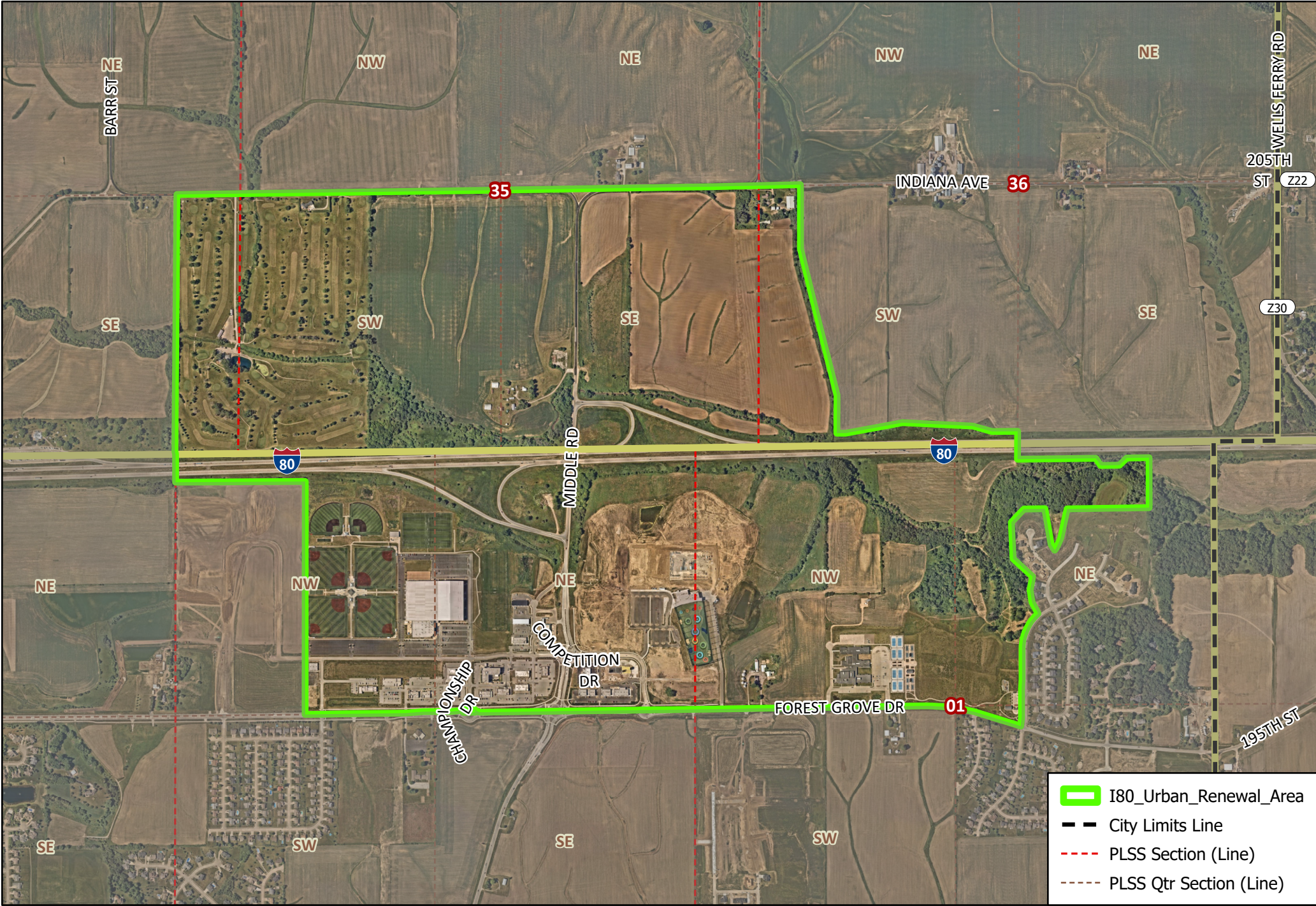
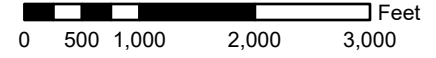

- I80_Urban_Renewal_Area
- City Limits Line
- PLSS Section (Line)
- PLSS Qtr Section (Line)



March 25, 2025

Honorable Mayor and
Members of the City Council
City of Bettendorf
Bettendorf, Iowa 52722

SUBJECT: Planning and Zoning Commission's recommendation on an ordinance amending Title 11, Chapter 14 – Sign Ordinance, Section 11-4-3(F) General Requirements and Restrictions – Public Service and Safety Signs and Section 11-4-8(B) Billboard Signs (Off-Premises Advertising) – Location.

Honorable Mayor and Members of the City Council:

On March 19, 2025, the Planning and Zoning Commission reviewed and recommended that your Honorable Body approve the above named ordinance amendments.

If you have any questions concerning this matter, please do not hesitate to contact this office.

Sincerely,

Mark D. Hunt
Director, Community Development

Public Hearing

8. Case 25-004-ORD; Amendment to Title 11, Chapter 14 of the City Code – Sign Ordinance. (Staff: Beswick)

Beswick reviewed the proposed amendment to Section 11-4-3(F) regarding public service and safety signs.

A brief discussion was held regarding the possibility of utilizing the banners at some point in the future to promote events taking place in the city, to acknowledge awareness weeks, or to celebrate local sports achievements.

Kappeler asked how the proposed banners are different than those that are displayed in the downtown area. Curran explained that they are not different, adding that staff's goal is to amend the code so that it is consistent with the present reality downtown and to add the TBK area as a permitted location as well as the sponsorship component of the banner. Beswick added that the ordinance also adds new sign types for public safety, legal notice, and public utility signs.

Stoltenberg asked if there is a means to limit the number, location, and separation distance for the signs. Curran explained that there will be an administrative policy which will regulate the types of poles on which the banners are allowed, limit the number and type of signs allowed in the right-of-way, and ensure that the signs are aesthetically-pleasing. He reiterated that the signs are only to be allowed on city-owned poles, adding that the city or an authorized vendor will be responsible for the maintenance of the signs.

Beswick reviewed the proposed amendment to Section 11-4-8(B) regarding billboard signs.

Wennlund asked if there are any existing billboards in the I-80 Urban Renewal Area that would become non-conforming. Beswick confirmed that there are some in the agricultural fields north of I-80, adding that they would not be required to be removed but would become legal non-conforming signs. Hunt commented that the area is becoming a major entry point into the city because of the upcoming I-80 interchange construction and the growth in the TBK area. He added that the city has given a lot of consideration to the first impression the area makes and that one of the top priorities is to prohibit billboards in the overlay district.

Kappeler asked if the existing billboards in the area would be eligible for conversion to a digital sign. Curran explained that once the ordinance is adopted, the non-conforming signs would not be allowed to be changed.

Stoltenberg opened the public hearing for Case 25-004-ORD and asked if there is proof of publication. Fuhrman confirmed this.

There being no one present wishing to speak in favor of or in opposition to the ordinance amendment, Stoltenberg closed the public hearing.

On motion by Kappeler, seconded by Wennlund, that the ordinance amending Sections 11-4-3(F) and 11-4-8(B) of Title 11, Chapter 14 of the City Code – Sign Ordinance be recommended for approval subject to staff recommendations.

AYE: Gibson, Kappeler, Scaife, Stoltenberg, Wennlund

NAY: None

ALL AYES

Motion carried.

**CITY OF BETTENDORF
COMMITTEE OF THE WHOLE MEETING MINUTES**

MARCH 31, 2025

The City Council of Bettendorf, Iowa held their Committee of the Whole on Tuesday, March 31, 2025, at 5:00 p.m., in the Council Chambers at Bettendorf City Hall, 1609 State Street, Bettendorf, Iowa.

The City of Bettendorf broadcasted this public meeting online at www.bettendorf.org/YouTube.

Council Members Present: Adamson, Jager, Brown, Naumann, Sechser, Baden

Council Members Absent: Palczynski

Presiding: Mayor Robert S. Gallagher

CONSENT AGENDA ITEMS

Community Development Director Mark Hunt and Senior City Planner Taylor Beswick gave an explanation of the resolution setting a public hearing date on an ordinance amending Bettendorf City Code Title 11, Chapter 14 – Sign Ordinance. Mayor Gallagher asked council for any questions. Council Member Adamson questioned staff regarding the light pole banners, and Mr. Hunt, Mr. Beswick, Assistant City Administrator/Economic Development Director Jeff Reiter, and City Attorney Chris Curran responded accordingly. Mayor Gallagher asked for a motion to keep this item as Consent O for consideration at tomorrow evening’s regular city council meeting. Council Member Jager made the motion, and Council Member Naumann seconded the motion. Viva Voce indicated all ayes, and the motion passed unanimously.

(Consent O)

Assistant City Administrator/Economic Development Director Jeff Reiter gave an explanation of the resolution authorizing staff to issue an informational letter and survey for the construction of a new police station. Mayor Gallagher asked council for any questions. Council Members Jager and Adamson questioned staff regarding the survey, and City Administrator Decker Ploehn and Mr. Reiter responded accordingly. Council Member Brown asked staff for a consultant’s timeline of activities between now and the referendum, and Mr. Ploehn responded one would be provided. Council Member Naumann asked if the public would be provided a breakdown of the costs of the construction. Mr. Reiter responded that there will be a formation of a non-public official, non-staff committee that will provide information to the public through public meet and greets, neighborhood meetings, as well as public informational meetings at the Waterfront Convention Center on April 28th and 30th. Mayor Gallagher asked for a motion to keep this item as Consent R for consideration at tomorrow evening’s regular city council meeting. Council Member Baden made the motion, and Council Member Naumann seconded the motion. Viva Voce indicated all ayes, and the motion passed unanimously. **(Consent R)**

Mayor Gallagher asked council for any questions on the remaining consent agenda items. Council Member Sechser questioned staff regarding the standards on Item N, and Community Development Director Mark Hunt responded accordingly. Mayor Gallagher asked for a motion to approve the remaining consent agenda items as presented for consideration at tonight's regular city council meeting. Council Member Adamson made a motion to approve same, and Council Member Jager seconded the motion. Viva Voce indicated all ayes, and the motion passed unanimously.

ITEMS TO APPEAR

No discussion was held.

ITEMS ADDED BY MAYOR AND COUNCIL

No items were added by Mayor and/or Council.

PRESENTATION

Community Development Director Mark Hunt and Senior City Planner Taylor Beswick gave an update on the proposed new Zoning Ordinance. Mr. Hunt, Mr. Beswick, and City Attorney Chris Curran received and answered questions accordingly as they arose.

ADJOURNMENT

There being no further business, Council Member Sechser made a motion to adjourn, and Council Member Baden seconded the motion. The meeting was adjourned at approximately 6:05 p.m.

Mayor Robert S. Gallagher

Attest:

City Clerk Decker P. Ploehn

**CITY OF BETTENDORF
SPECIAL CITY COUNCIL MEETING MINUTES**

APRIL 1, 2025

The City Council of Bettendorf, Iowa met in special session on Tuesday, April 1, 2025, at 6:30 p.m., in the Council Chambers at Bettendorf City Hall, 1609 State Street, Bettendorf, Iowa.

The city of Bettendorf broadcasted this public meeting online at www.bettendorf.org/YouTube.

Council Members Present: Adamson, Jager, Brown, Naumann, Sechser, Baden

Council Members Absent: Palczynski

Presiding: Mayor Robert S. Gallagher

Mayor Gallagher opened the meeting promptly at 6:30 p.m.

PUBLIC HEARING REGARDING THE PROPOSED FY2025/26 PROPERTY TAX LEVY RATE

Finance Director Jason Schadt gave an explanation of the public hearing including that no action is required at tonight's meeting. Mayor Gallagher asked for any questions from Council. None presented. Mayor Gallagher verified that the Notice of Public Hearing had been published and no written correspondence had been received on the matter. Mayor Gallagher then opened the public hearing. No one addressed the Council, and the Public Hearing was closed.

ADJOURNMENT

There being no further business, Council Member Naumann made a motion to adjourn, and Council Member Baden seconded the motion. The meeting was adjourned at approximately 6:38 p.m.

Mayor Robert S. Gallagher

Attest:

City Clerk Decker P. Ploehn

**CITY OF BETTENDORF
CITY COUNCIL MEETING MINUTES**

APRIL 1, 2025

The City Council of Bettendorf, Iowa met in regular session on Tuesday, April 1, 2025, at 7:00 p.m., in the Council Chambers at Bettendorf City Hall, 1609 State Street, Bettendorf, Iowa.

The City of Bettendorf broadcasted this public meeting online at www.bettendorf.org/YouTube.

Council Members Present: Adamson, Jager, Brown, Naumann, Sechser, Baden,

Council Members Absent: Palczynski

Presiding: Mayor Robert S. Gallagher

Mayor Gallagher opened the meeting with the Pledge of Allegiance followed by an Invocation given by Pastor Ed Hedding of Pleasant View Baptist Church.

PROCLAMATION

Mayor Gallagher issued a proclamation declaring April 3, 2025, as J.A. Day in the Bettendorf community. The proclamation was requested by Junior Achievement of the Heartland, and received by Linda Wood, Development Director for Junior Achievement of the Heartland.

PUBLIC REQUESTS OF COUNCIL

No one addressed the Council, and the session was closed.

PUBLIC HEARING REGARDING THE 2025 STREET RESURFACING PROGRAM

Mayor Gallagher verified that the Notice of Public Hearing had been published and no written correspondence had been received on the matter. Mayor Gallagher then opened the public hearing. No one addressed the Council, and Public Hearing was closed.

RESOLUTION

Council Member Sechser presented a resolution approving the plans, specifications, and form of contract for the 2025 Street Resurfacing Program, and made a motion to approve the resolution as presented. Council Member Baden seconded the motion. Mayor Gallagher asked for any discussion from Council.

None presented. Roll call vote indicated Jager (aye); Brown (aye); Naumann (aye); Sechser (aye); Baden (aye); and Adamson (aye). The motion passed 6-0.

PUBLIC HEARING REGARDING THE HAPPY JOE DRIVE RECONSTRUCTION PROJECT

Mayor Gallagher verified that the Notice of Public Hearing had been published and no written correspondence had been received on the matter. Mayor Gallagher then opened the public hearing. No one addressed the Council, and Public Hearing was closed.

RESOLUTION

Council Member Naumann presented a resolution approving the plans, specifications, and form of contract for the Happy Joe Drive Reconstruction Project, and made a motion to approve the resolution as presented. Council Member Sechser seconded the motion. Mayor Gallagher asked for any discussion from Council. None presented. Roll call vote indicated Jager (aye); Brown (aye); Naumann (aye); Sechser (aye); Baden (aye); and Adamson (aye). The motion passed 6-0.

ORDINANCE – SECOND AND FINAL READING REGARDING AMENDING CERTAIN CITY CODE SECTIONS AND ADJUSTING THE RATES FOR STORMWATER UTILITY (9-1-7), SEWER UTILITY (8-2-7(H)), AND SOLID WASTE ENTERPRISE ACTIVITIES OF THE CITY (8-3B-14)

Mayor Gallagher explained that staff is requesting to waive the third reading of this ordinance, and asked for a motion for same. Council Member Naumann made the motion to waive the third reading, and Council Member Adamson seconded the motion. Roll call vote to waive the third reading indicated Jager (aye); Brown (aye); Naumann (aye); Sechser (aye); Baden (aye); and Adamson (aye). The motion passed 6-0.

Council Member Baden presented the second and final reading of an ordinance amending certain city code sections and adjusting the rates for Stormwater Utility (9-1-7), Sewer Utility (8-2-7(H)), and Solid Waste Enterprise Activities of the City (8-3B-14), and made a motion to approve the ordinance at its final reading as presented. Council Member Naumann seconded the motion. Mayor Gallagher asked for any discussion from Council. Council Member Jager confirmed that the effective date of rate adjustment is April 1, 2025. Roll call vote indicated Jager (aye); Brown (aye); Naumann (aye); Sechser (aye); Baden (aye); and Adamson (aye). The motion passed 6-0.

CONSENT AGENDA

Mayor Gallagher asked for a motion to approve the Consent Agenda as presented. Council Member Naumann made a motion to approve the Consent Agenda as presented, and Council Member Brown seconded the motion. Mayor Gallagher asked Council for any questions. None presented. Roll call vote indicated Jager (aye); Brown (aye); Naumann (aye); Sechser (aye); Baden (aye); and Adamson (aye). The motion passed 6-0.

ADJOURNMENT

There being no further business, Council Member Naumann made a motion to adjourn, and Council Member Baden seconded the motion. The meeting was adjourned at approximately 7:12 p.m.

Mayor Robert S. Gallagher

Attest:

City Clerk Decker P. Ploehn

CONSENT AGENDA

APRIL 1, 2025

ALL ITEMS APPEARING BELOW ARE CONSIDERED ROUTINE BY THE CITY COUNCIL AND SHALL BE ENACTED BY ONE MOTION. IF DISCUSSION IS DESIRED, THAT ITEM SHALL BE REMOVED AND DISCUSSED SEPARATELY

- A. Minutes from March 18, 2025 (Approve and Adopt)
- B. Resolution setting a date for a public hearing on the adoption of the FY2025/26 Budget and Certification of Taxes. (Approve and Adopt)
- C. Resolution approving an Agreement for Transfer of Stormwater Detention Facility between the city of Bettendorf and JCO Storage, LLC. (Approve and Adopt)
- D. Resolution setting the date for a public hearing and directing the advertising for bids for the 2025 Full Depth Patching Program. (Approve and Adopt)
- E. Resolution setting the date for a public hearing and directing the advertising for bids for the Devils Glen Road Over Duck Creek – Bridge Approach and Joint Replacement Project. (Approve and Adopt)
- F. Resolution awarding the contract and approving the contract and bond for the 2025 Pavement Preservation Program. (Approve and Adopt)
- G. Resolution awarding the contract and approving the contract and bond for the 2025 Pavement Markings Program. (Approve and Adopt)
- H. Resolution awarding the contract and approving the contract and bond for the 2025 Downtown Landscape Planting and Maintenance Program. (Approve and Adopt)
- I. Resolution authorizing the Director of Public Works to issue a purchase order to Big Top Manufacturing for the replacement of the salt storage hoop building at the Maintenance Center. (Approve and Adopt)

- J. Resolution authorizing the Director of Public Works to execute an agreement with MidAmerican Energy for a primary electric service extension for the Spencer Creek Lift Station Project. (Approve and Adopt)
- K. Resolution ordering the installation of street lights in Hope Heights 3rd Addition. (Approve and Adopt)
- L. Resolution approving the final plat of Blackbird Heights Addition (Replat of Lot 1 in Highland Ridge Third Addition), submitted by G2 Partners, LLC (Case 25-005-REPL). (Approve and Adopt)
- M. Resolution approving the final plat of Gipple's Second Addition (Replat of Gipple's First Addition and Lot 4 and Lot A in Blackbird Heights Addition), submitted by Todd Gipple (Case 25-006- REPL). (Approve and Adopt)
- N. Resolution approving the final plat of Spencer Hollow 6th Addition (Replat of Lot B in Spencer Hollow 4th Addition), submitted by Ven Green Land Development, LLC (Case 25-012-REPL). (Approve and Adopt)
- O. Resolution setting a date for a public hearing on an ordinance amending Title 11, Chapter 14 of the City Code – Sign Ordinance (Case 25-004-ORD). (Approve and Adopt)
- P. Resolution approving the reappointment of Ralph W. Heninger to Civil Service Commission with the city of Bettendorf. (Approve and Adopt)
- Q. Resolution approving the Civil Service List submitted for the Police Officer position in the Police Department. (Approve and Adopt)
- R. Resolution authorizing staff to issue an informational letter and survey for the construction of a new police station. (Approve and Adopt)
- S. Resolution authorizing the Director of Parks and Recreation to issue a purchase order to Turfwerks in the amount of \$26,077.50 for a Progressive Pro-Flex 120 Tow-Behind Rotary Mower for Palmer Hills Golf Maintenance. (Approve and Adopt)

- T. Resolution authorizing the Director of Parks and Recreation to issue a purchase order to Kunau Implement in the amount of \$39,905.50 for a Kubota L6060 Tractor for Palmer Hills Golf Maintenance. (Approve and Adopt)

- U. Resolution approving alcohol license renewals and requests for Flip's Pancake House (Tanglefoot Ln), California Burritos Mexican Grill, Foundry, Rudy's Tacos, and Forest Grove Sports Complex. (Approve and Adopt)

- V. Bills (Approve payment and direct City Clerk to issue checks in respective amounts)

COUNCIL LETTER

MEETING DATE: April 15, 2025
REQUESTED BY: Brent O. Morlok, P.E., Assistant City Engineer



Item Title

Resolution setting the date for a public hearing and directing the advertising for bids for the Gateway Pedestrian Bridge & Trails Phase II Project.

Explanation

The proposed project will consist of constructing a new pedestrian bridge with aesthetic color changing lighting and associated recreational trail extensions across and around the Middle Rd corridor north of Forest Grove Dr and south of Interstate 80.

The proposed scope of work itself includes constructing two segments of ten foot (10') wide trail consisting of Portland Cement Concrete pavement and measuring approximately 143 and 780 linear feet, that lead up to a bridge structure. The bridge structure measures approximately 1,000 linear feet spanning Middle Road and adjacent properties. The bridge consists of four (4) units including a butterfly arch bridge utilizing a built-up steel box arch rib, steel hangers, and a longitudinally post-tensioned concrete precast panel deck floor system supported on aesthetic concrete arch supports founded on steel piling. Additionally, the bridge includes three (3) approach units consisting of cast-in-place concrete deck on built-up steel plate girders supported by aesthetic hammerhead piers and stub abutments founded on steel piling. Electrical work consists of new bridge decorative lighting, trail lighting, and associated lighting controls and circuiting. Associated grading, sidewalk pavement, storm sewer installation, segmental block retaining wall design and installation, seeding, sodding, erosion control, and land and hardscape work are also included.

Relationship to Goals: Upgraded City Infrastructure & Public Facilities.

If the matter is not budgeted in the current year, explain why funding is requested and the anticipated source:

This project (PW0580) was approved with a total budget of \$11,735,000 within the Community Improvement Program (CIP). Please note that this purchase order is one of several that will be bid and issued under this project number and associated budget. The current budget summary is as follows:

Total CIP Budget	\$ 11,735,000.00
POs Issued to Date	<u>\$ 1,817,875.00</u>
Remaining Budget	\$ 9,917,125.00

List Attachments

Resolution; Notice to Bidders; Notice of Public Hearing

RESOLUTION SETTING THE DATE FOR A PUBLIC HEARING AND DIRECTING THE ADVERTISING FOR BIDS FOR THE GATEWAY PEDESTRIAN BRIDGE & TRAILS PHASE II PROJECT

WHEREAS, this Council deems it necessary and advisable under the provisions of the Code of Iowa to construct certain improvements to the trail system of Bettendorf, Iowa, namely, the

Gateway Pedestrian Bridge & Trails Phase II Project

as hereinafter described and has ordered plans, specifications, form of contract and engineer's estimate to be prepared and said documents are now on file in the office of the City Engineer for public inspection.

NOW, THEREFORE BE IT RESOLVED that the council will conduct a public hearing on the final adoption of the plans, specifications, notice to bidders, and form of contract for the construction of the improvements in the City Hall Council Chambers, 1609 State Street, Bettendorf, Iowa at 7:00 o'clock p.m. on the 6th day of May, 2025, and the City Clerk is hereby directed to give notice of the hearing, said notice to be published at least once as provided by law, not less than four (4) nor more than twenty (20) days before the date fixed for the hearing.

BE IT FURTHER RESOLVED that the City Engineer be authorized to receive bids for the construction of said improvements through the electronic bid submission system at <https://bettendorf.ionwave.net> until 10:00 o'clock a.m. on the 27th day of May, 2025, and the City Clerk is hereby directed to give notice to the taking of bids, said notice is to be posted in a relevant contractor plan room service with statewide circulation, a relevant construction lead generating service with statewide circulation and on the City's website with such publication to be not less than thirteen (13) days nor more than forty five (45) days before the date of the letting.

BE IT FURTHER RESOLVED that a cashier's or certified check, Credit Union Certified Share Draft, or bid bond to accompany each bid, as security, be submitted with the bid. The bidder will enter into a contract for the work bid upon and will furnish a corporate surety bond acceptable to the Council for faithful performance of the contract, in the amount of ten percent (10%) of the bid amount.

Passed, Approved and Adopted this 15th day of April 2025.

Robert S. Gallagher, Mayor

Attest:

Decker P. Ploehn, City Clerk

NOTICE TO BIDDERS

Sealed bids will be received by the City of Bettendorf, Iowa, through their electronic bid submission system at <https://bettendorf.ionwave.net> until **10:00 A.M.** on the **27th day of May, 2025**, for the **Gateway Pedestrian Bridge & Trails – Phase II** project and related work as described in the plans and specifications now on file in the office of the City Clerk. Bids shall be submitted to the City Council for consideration and action at a subsequent meeting.

A mandatory Pre-Bid Meeting will be held at 11:00 A.M. on the 6th day of May, 2025. This will be held at the Engineering Division of Public Works, 4403 Devils Glen Rd., Bettendorf, Iowa on the second floor.

The proposed scope of work for this project includes constructing two segments of ten foot (10') wide trail consisting of Portland Cement Concrete pavement and measuring approximately 143 and 780 linear feet, that lead up to a bridge structure. The bridge structure measures approximately 1,000 linear feet spanning Middle Road and adjacent properties. The bridge consists of four units including a butterfly arch bridge utilizing a built-up steel box arch rib, steel hangers, and a longitudinally post-tensioned concrete precast panel deck floor system supported on aesthetic concrete arch supports founded on steel piling. Additionally, the bridge includes three approach units consisting of cast-in-place concrete deck on built-up steel plate girders supported by aesthetic hammerhead piers and stub abutments founded on steel piling. Electrical work consists of new bridge decorative lighting, trail lighting, and associated lighting controls and circuiting, providing all electrical materials except for those items specifically called as by the City of Bettendorf on the Plans. Associated earthen grading, sidewalk pavement, storm sewer installation, segmental block retaining wall design and installation, seeding, sodding, erosion control, and land and hardscape work are included. One bid alternate item is included for color-changing aesthetic lighting on the bridge railings.

The bidder to whom the Contract is awarded shall commence work no later than the date to begin work set forth in a Notice to Proceed from the City or its authorized representative, to the Contractor. All work shall be done in strict compliance with the plans and specifications prepared by the Engineer of the Engineering Division of the Public Works Department of Bettendorf, Iowa.

All work on this contract shall commence no later than July 14, 2025 and be substantially completed by November 30, 2026. Final seeding completion date shall be April 15, 2027. The beginning and completion dates will be included in and made part of the contract between the successful bidder and the City. Liquidated damages in the amount of One-Thousand Five-Hundred Dollars and no/100 (\$1,500.00) per calendar day shall be charged for every day past the substantial completion date.

The plans, specifications and all bid documents, hereinafter called proposed Contract Documents, are placed on file and are available for inspection on the City of Bettendorf's electronic bid submission website: <https://bettendorf.ionwave.net>. If you haven't already done so, you will need to register as a supplier at the website to submit a bid. All bids must be submitted electronically. No paper, emailed, or faxed bids will be accepted, and no physical bid opening shall be held. All bids will be evaluated by the City's electronic bid submission system.

Copies of the proposed Contract Documents for said improvements may be obtained with a forty-eight (48) hour notice at the Engineering Division of Public Works, 4403 Devils Glen Rd., Bettendorf, Iowa by calling (563) 344-4055. Paper sets require a refundable deposit of Two Hundred Fifty Dollars (\$250.00) for each set that shall be refunded within fourteen (14) days after the award of the project. If the Contract Documents are not returned in a timely manner and in a reusable condition, the deposit, or portions thereof, may be forfeited.

Each proposal must be accompanied by a certified or cashier's check drawn on an Iowa bank or a bank chartered under the laws of the United States or by a Bid Bond with corporate surety satisfactory to the City of Bettendorf in the amount of ten (10) percent of the bid, made payable to the City Treasurer of the City of Bettendorf, Iowa, and may be cashed or claim made against the bond by the Treasurer of the City of Bettendorf, Iowa, as liquidated damages in the event the successful bidder fails to enter into a contract within ten (10) days and post bond satisfactory to the City for the faithful performance of the work. Checks or Bid Bonds of the three lowest bidders may be retained for a period of not to exceed thirty (30) days or until a contract is awarded or rejection is made, whichever is sooner. Other checks and Bid Bonds will be returned after the tabulation of the bids is completed.

The successful bidder will be required to furnish a performance and maintenance bond equal to One Hundred Percent (100%) of the contract price. Said bond is to be issued by a responsible surety approved by the City Council and shall guarantee the faithful performance of the contract and shall also guarantee the maintenance of the improvement for a period of four (4) years from and after its completion and acceptance by the City.

Contractors and subcontractors on this project will undergo a standardized evaluation upon completion of the work. The results of this evaluation may influence the determination of the contractor's eligibility to bid on future projects as governed by the current policies adopted by the City of Bettendorf City Council.

By virtue of statutory authority, a preference will be given to products and provisions grown and coal produced within the State of Iowa and to Iowa domestic labor. A preference will be given to resident Bidders in Accordance with Chapter 73 of the Code of Iowa.

Plans and specifications governing the construction of the proposed improvements and prior proceedings of the City Council referring to and defining said proposed improvements are hereby made a part of this notice and the proposed contract shall be executed in compliance therewith.

The City reserves the right to reject any or all proposals and to waive technicalities and irregularities if deemed necessary and approved by City Council.

Published upon order of the City Council of Bettendorf, Iowa.

Brent Morlok, P.E.
City Engineer

NOTICE OF PUBLIC HEARING

To Whom It May Concern:

Notice is hereby given that on the 6th day of May, 2025, at 7:00 p.m., the City Council of the City of Bettendorf, Iowa, will conduct a public hearing at City Hall, Council Chambers, 1609 State Street, regarding the adoption of plans, specifications, notice to bidders, and form of contract for the construction of the improvements for the Gateway Pedestrian Bridge and Trails Phase II Project.

The City Council has set said hearing at the time and place specified. Written suggestions or objections concerning this issue may be filed with the City Clerk at or before such hearing and will be heard by the City Council at the time and place specified.

Interested persons desiring to present their views upon the issue, either in writing or verbally, will be given the opportunity to be heard at the above-mentioned time and place.

Dated at Bettendorf, Iowa, this 15th day of April, 2025

Decker P. Ploehn, City Clerk

COUNCIL LETTER

MEETING DATE: April 15, 2025
REQUESTED BY: Brent Morlok, P.E., City Engineer



Item Title

Resolution awarding the contract and approving the contract and bond for the 2025 Street Resurfacing Program.

Explanation

The proposed improvements consist of rotomilling, pavement removal, installing granular subbase, resurfacing various streets with Hot Mix Asphalt (HMA), constructing storm sewer, curb and gutter, driveways and sidewalks, and other related work within the city of Bettendorf, Iowa. A list of streets to be completed under this year's program is noted below.

2025 Street Resurfacing Program List

Location	From	To	Ward
Dundee Lane	Stafford Boulevard	29th Street	2
Aspen Hills Drive	Apple Valley Drive	PCC Header S. of New Lexington Drive	4
New Lexington Drive	18th Street	Aspen Hills Drive	4
Lexington Court	New Lexington Drive	Cul-de-sac	4
Kingsway Drive	18th Street	Cul-de-sac	4
Keeneland Court	Kingsway Drive	Cul-de-sac	4

Bids were received on April 8, 2025. Manatts, Inc. – Eastern Iowa Asphalt of Camanche, Iowa was the low bidder of seven (7) bids received. Bids ranged from the high of \$945,825.79 to the low of \$727,760.89, which is 26.65% below the engineers estimate of \$992,158.25. Please note that the engineers estimate was derived using 2024 bid pricing and applying a small inflation factor. This year's pricing was significantly lower. Due to this very competitive pricing, staff is requesting that the entire budget amount of \$1,000,000 be authorized so an additional street can be added to the program. The next street on the Pavement Management Program list that would be the appropriate size and dollar amount for the remaining funding is **Bunker Hill Dr** from Terrace Park Dr to the southern end.

If the matter is not budgeted in the current year, explain why funding is requested and the anticipated source:

The overall project (PW0593 & RU0049) was approved with a total budget of \$1,000,000 within the Community Improvement Program (CIP). As noted above, staff is requesting to add an additional street to the contract and utilize the full approved budget amount.

List Attachments

Resolution; Bid Tabulation; Contract.

RESOLUTION NO. _____ -25

**RESOLUTION AWARDING THE CONTRACT AND APPROVING THE CONTRACT AND BOND
FOR THE 2025 STREET RESURFACING PROGRAM**

WHEREAS, plans, specifications, and form of contract were approved by this City Council for the construction of improvements to the street system of said City; namely, the

2025 Street Resurfacing Program

WHEREAS, bids were accepted for the construction of the above project on the 8th day of April, 2025, with Manatts, Inc. – Eastern Iowa Asphalt submitting the lowest responsible quote in the amount of \$727,760.89 and

WHEREAS, appropriately executed contract and bond have been submitted by the Contractor in conformance with the plans and specifications as described above.

NOW, THEREFORE BE IT RESOLVED BY THE CITY COUNCIL OF THE CITY OF BETTENDORF, IOWA, that

1. The bid of Manatts, Inc. – Eastern Iowa Asphalt is hereby accepted for the 2025 Street Resurfacing Program in the amount of \$727,760.89.
2. The Mayor and City Administrator are hereby authorized to sign the contract for the construction of said project.
3. The award of contract under this resolution is expressly subject to the bidder providing all necessary bonds and insurance documents; on the bidder's signing of the contract as provided in the form of contract, and no further facts or issues coming to light between the passage of this resolution and the actual signing of the contract by a representative of the City such as would cause the City to reconsider, defer, to stop the decision to enter into the contract.
4. A total purchase order amount of \$1,000,000.00, is hereby approved. This amount will permit staff to add an additional street to the program to utilize the full approved budget amount.

Passed, Approved and Adopted this 15th day of April, 2025.

Robert S. Gallagher, Mayor

Attest:

Decker P. Ploehn, City Clerk

2025 Street Resurfacing Program

Bid Open: April 8, 2025

Line #	Description	QTY	UOM	Manatts, Inc. - Eastern Iowa Asphalt		CDMI Concrete Contractors Inc.		Hawkeye Paving Corp		Phoenix Corporation of the Quad Cities		Eastern Iowa Excavating & Concrete, LLC		Brandt Construction Co		LANGMAN CONSTRUCTION, INC.	
				Total Price		Total Price		Total Price		Total Price		Total Price		Total Price		Total Price	
				Unit	Extended	Unit	Extended	Unit	Extended	Unit	Extended	Unit	Extended	Unit	Extended	Unit	Extended
1	Traffic Control	1	LS	\$18,000.00	\$18,000.00	\$22,000.00	\$22,000.00	\$7,000.00	\$7,000.00	\$36,000.00	\$36,000.00	\$56,500.00	\$56,500.00	\$40,000.00	\$40,000.00	\$80,000.00	\$80,000.00
2	Pavement Driveway and Sidewalk Removal	2468	SY	\$13.50	\$33,318.00	\$20.00	\$49,360.00	\$10.00	\$24,680.00	\$14.00	\$34,552.00	\$45.65	\$112,664.20	\$23.00	\$56,764.00	\$12.00	\$29,616.00
3	Full Depth Sawcut	67	LF	\$15.00	\$1,005.00	\$24.00	\$1,608.00	\$4.00	\$268.00	\$10.00	\$670.00	\$5.25	\$351.75	\$7.00	\$469.00	\$5.00	\$335.00
4	Curb & Gutter	2508	LF	\$43.00	\$107,844.00	\$47.00	\$117,876.00	\$32.00	\$80,256.00	\$51.50	\$129,162.00	\$34.25	\$85,899.00	\$41.00	\$102,828.00	\$47.60	\$119,380.80
5	Granular Subbase, 6"	710	SY	\$13.00	\$9,230.00	\$12.00	\$8,520.00	\$15.00	\$10,650.00	\$24.25	\$17,217.50	\$16.00	\$11,360.00	\$9.40	\$6,674.00	\$14.60	\$10,366.00
6	Granular Subbase, 12"	1178	SY	\$26.00	\$30,628.00	\$26.00	\$30,628.00	\$26.00	\$30,628.00	\$31.50	\$37,107.00	\$20.25	\$23,854.50	\$58.00	\$68,324.00	\$23.00	\$27,094.00
7	Engineering Fabric	200	SY	\$2.50	\$500.00	\$6.00	\$1,200.00	\$2.00	\$400.00	\$2.20	\$440.00	\$13.00	\$2,600.00	\$5.50	\$1,100.00	\$5.00	\$1,000.00
8	Detectable Warning Surfaces at ADA Curb Ramps	80	SF	\$51.50	\$4,120.00	\$45.00	\$3,600.00	\$50.00	\$4,000.00	\$47.50	\$3,800.00	\$37.50	\$3,000.00	\$56.00	\$4,480.00	\$99.00	\$7,920.00
9	Sidewalk, 4" P.C.C.	2588	SF	\$12.00	\$31,056.00	\$9.75	\$25,233.00	\$14.00	\$36,232.00	\$10.00	\$25,880.00	\$7.55	\$19,539.40	\$11.00	\$28,468.00	\$9.00	\$23,292.00
10	Driveway, 6" P.C.C. (Granular Subbase, 6" Incidental)	225	SY	\$93.00	\$20,925.00	\$101.00	\$22,725.00	\$92.00	\$20,700.00	\$131.00	\$29,475.00	\$81.00	\$18,225.00	\$120.00	\$27,000.00	\$90.00	\$20,250.00
11	Full Depth Patch PCC	255	SY	\$105.00	\$26,775.00	\$125.00	\$31,875.00	\$115.00	\$29,325.00	\$80.00	\$20,400.00	\$124.25	\$31,683.75	\$130.00	\$33,150.00	\$115.00	\$29,325.00
12	Rotomilling	11143	SY	\$3.80	\$42,343.40	\$3.00	\$33,429.00	\$8.00	\$89,144.00	\$4.65	\$51,814.95	\$4.20	\$46,800.60	\$6.00	\$66,858.00	\$15.00	\$167,145.00
13	Base Preparation	11143	SY	\$1.90	\$21,171.70	\$1.50	\$16,714.50	\$1.00	\$11,143.00	\$2.00	\$22,286.00	\$2.15	\$23,957.45	\$2.00	\$22,286.00	\$6.00	\$66,858.00
14	Crushed Rock Stabilization	126	TONS	\$35.00	\$4,410.00	\$52.00	\$6,552.00	\$20.00	\$2,520.00	\$20.00	\$2,520.00	\$39.65	\$4,995.90	\$30.00	\$3,780.00	\$30.00	\$3,780.00
15	HMA Hand Method	60	TN	\$150.00	\$9,000.00	\$300.00	\$18,000.00	\$150.00	\$9,000.00	\$350.00	\$21,000.00	\$167.00	\$10,020.00	\$290.00	\$17,400.00	\$100.00	\$6,000.00
16	HMA Standard Traffic (ST) surface, 3/8", PG 58-28H	2254	TN	\$105.00	\$236,670.00	\$103.00	\$232,162.00	\$129.00	\$290,766.00	\$119.50	\$269,353.00	\$115.00	\$259,210.00	\$114.00	\$256,956.00	\$106.24	\$239,464.96
17	HMA Standard Traffic (ST) Base, 3/4", PG 58-28S	223	TN	\$105.00	\$23,415.00	\$100.00	\$22,300.00	\$138.00	\$30,774.00	\$116.50	\$25,979.50	\$115.00	\$25,645.00	\$122.00	\$27,206.00	\$119.40	\$26,626.20
18	Water Service Lines, Lower or Replace	100	LF	\$110.00	\$11,000.00	\$10.00	\$1,000.00	\$10.00	\$1,000.00	\$25.00	\$2,500.00	\$94.50	\$9,450.00	\$50.00	\$5,000.00	\$10.00	\$1,000.00
19	Manhole Adjustment	5	EA	\$1,400.00	\$7,000.00	\$1,300.00	\$6,500.00	\$1,500.00	\$7,500.00	\$1,500.00	\$7,500.00	\$1,255.00	\$6,275.00	\$1,660.00	\$8,300.00	\$1,500.00	\$7,500.00
20	Chimney Seals	5	EA	\$980.00	\$4,900.00	\$1,061.35	\$5,306.75	\$1,500.00	\$7,500.00	\$1,200.00	\$6,000.00	\$615.00	\$3,075.00	\$1,050.00	\$5,250.00	\$800.00	\$4,000.00
21	Intake Adjustment	7	EA	\$1,250.00	\$8,750.00	\$1,650.00	\$11,550.00	\$2,000.00	\$14,000.00	\$1,750.00	\$12,250.00	\$2,155.00	\$15,085.00	\$2,025.00	\$14,175.00	\$1,750.00	\$12,250.00
22	Intake Removal	4	EA	\$775.00	\$3,100.00	\$303.00	\$1,212.00	\$600.00	\$2,400.00	\$900.00	\$3,600.00	\$735.00	\$2,940.00	\$535.00	\$2,140.00	\$1,000.00	\$4,000.00
23	Single Intake, Std	3	EA	\$5,150.00	\$15,450.00	\$4,250.00	\$12,750.00	\$5,200.00	\$15,600.00	\$3,600.00	\$10,800.00	\$4,025.00	\$12,075.00	\$5,300.00	\$15,900.00	\$4,000.00	\$12,000.00
24	Double Intake, Std	2	EA	\$6,000.00	\$12,000.00	\$6,500.00	\$13,000.00	\$7,800.00	\$15,600.00	\$6,250.00	\$12,500.00	\$5,885.00	\$11,770.00	\$7,800.00	\$15,600.00	\$6,000.00	\$12,000.00
25	Storm Sewer, 15"	30	LF	\$98.00	\$2,940.00	\$166.00	\$4,980.00	\$130.00	\$3,900.00	\$96.00	\$2,880.00	\$122.50	\$3,675.00	\$205.00	\$6,150.00	\$98.00	\$2,940.00
26	Perforated Flexible Drain Tile, 4"	961	LF	\$19.00	\$18,259.00	\$12.00	\$11,532.00	\$14.00	\$13,454.00	\$16.00	\$15,376.00	\$15.00	\$14,415.00	\$23.00	\$22,103.00	\$12.00	\$11,532.00
27	Sump Drain Connection	3	EA	\$875.00	\$2,625.00	\$301.00	\$903.00	\$500.00	\$1,500.00	\$300.00	\$900.00	\$525.00	\$1,575.00	\$1,250.00	\$3,750.00	\$400.00	\$1,200.00
28	Downspout Outlet	1	EA	\$775.00	\$775.00	\$467.00	\$467.00	\$500.00	\$500.00	\$300.00	\$300.00	\$575.00	\$575.00	\$480.00	\$480.00	\$400.00	\$400.00
29	Filter Sock	730	LF	\$3.09	\$2,255.70	\$0.10	\$73.00	\$1.00	\$730.00	\$1.75	\$1,277.50	\$3.35	\$2,445.50	\$0.15	\$109.50	\$1.00	\$730.00
30	Intake Protection	22	EA	\$128.75	\$2,832.50	\$100.00	\$2,200.00	\$50.00	\$1,100.00	\$125.00	\$2,750.00	\$165.00	\$3,630.00	\$112.00	\$2,464.00	\$50.00	\$1,100.00
31	Select Topsoil, 4"	983	SY	\$7.73	\$7,598.59	\$8.00	\$7,864.00	\$12.00	\$11,796.00	\$9.00	\$8,847.00	\$8.00	\$7,864.00	\$11.00	\$10,813.00	\$7.00	\$6,881.00
32	Sodding and Fertilizing	983	SY	\$7.00	\$6,881.00	\$10.00	\$9,830.00	\$7.00	\$6,881.00	\$15.00	\$14,745.00	\$10.50	\$10,321.50	\$11.00	\$10,813.00	\$10.00	\$9,830.00
33	Chemical Spray Application	983	SY	\$1.00	\$983.00	\$0.01	\$9.83	\$0.01	\$9.83	\$0.20	\$196.60	\$0.50	\$491.50	\$0.01	\$9.83	\$0.01	\$9.83

FORM OF CONTRACT

THIS CONTRACT, made the 15th day of April, A.D., 2025, by and between
Manatt's, Inc., hereinafter called the "Contractor", and the
 City of Bettendorf, Scott County, Iowa, hereinafter called the "City",

WITNESSETH, That the Contractor and the City for the consideration stated herein agree as follows:

ARTICLE I. SCOPE OF WORK - The Contractor shall perform everything required to be performed and shall provide and furnish all of the labor, materials, necessary tools, expendable equipment, and all utility and transportation services required to perform and complete in a workmanlike manner all the work required in connection with the construction of the **2025 Street Resurfacing Program.**, all in strict accordance with the plans and specifications, including any and all addenda prepared by Engineering Division of the Public Works Department of the City of Bettendorf, Iowa, which plans and specifications are made a part of this contract; and in strict compliance with the Contractor's proposal and the other contract documents herein mentioned which are a part of this contract. The Contractor shall do everything required by this contract and the other documents constituting a part thereof.

ARTICLE II. THE CONTRACT PRICE - The City shall pay to the Contractor for the performance of this contract, subject to any additions or deductions provided therein, in current funds, the contract price of:

Seven Hundred Twenty-Seven Thousand, Seven Hundred Sixty Dollars and 89/100 (\$727,760.89)

computed as follows:

Base Bid

Item No.	Description	Quantity	Units	Unit Price	Total Price
1	Traffic Control	1	LS	\$18,000.00	\$18,000.00
2	Pvmt Driveway and Sidewalk Removal	2,468	SY	\$13.50	\$33,318.00
3	Full Depth Sawcut	67	LF	\$15.00	\$1,005.00
4	Curb and Gutter	2,508	LF	\$43.00	\$107,844.00
5	Granular Subbase, 6"	710	SY	\$13.00	\$9,230.00
6	Ganular Subbase, 12"	1,178	SY	\$26.00	\$30,628.00
7	Engineering Fabric	200	SY	\$2.50	\$500.00
8	Detectable Warning Surfaces at ada Curb Ramps	80	SF	\$51.50	\$4,120.00
9	Sidewalk, 4" PCC	2,588	SF	\$12.00	\$31,056.00
10	Driveway 6" PCC (Granular Subbase , 6" Incidental)	225	SY	\$93.00	\$20,925.00
11	Full Depth Patch PCC	255	SY	\$105.00	\$26,775.00
12	Rotomilling	11,143	SY	\$3.80	\$42,343.40
13	Base Preperation	11,143	SY	\$1.90	\$21,171.70
14	Crushed Rock Stabilization	126	TN	\$35.00	\$4,410.00
15	HMA Hand Method	60	TN	\$150.00	\$9,000.00
16	HMA Standard Traffic (ST) Surface, 3/8", PG 58-28H	2,254	TN	\$105.00	\$236,670.00
17	HMA Standard Traffic (ST) Base, 3/4", PG 58-28S	223	TN	\$105.00	\$23,415.00
18	Water Service Lines, Lower or Replace	100	LF	\$110.00	\$11,000.00
19	Manhole Adjustment	5	EA	\$1,400.00	\$7,000.00
20	Chimney Seals	5	EA	\$980.00	\$4,900.00
21	Intake Adjustment	7	EA	\$1,250.00	\$8,750.00
22	Intake, Removal	4	EA	\$775.00	\$3,100.00
23	Single Intake, Std	3	EA	\$5,150.00	\$15,450.00
24	Double Intake, Std	2	EA	\$6,000.00	\$12,000.00
25	Storm Sewer, 15"	30	LF	\$98.00	\$2,940.00
26	Perforated Flexible Drain Tile, 4"	961	LF	\$19.00	\$18,259.00
27	Sump Drain Connection	3	EA	\$875.00	\$2,625.00
28	Downspout Outlet	1	EA	\$775.00	\$775.00
29	Filter Sock	730	LF	\$3.09	\$2,255.70
30	Intake protection	22	EA	\$128.75	\$2,832.50
31	Select Top Soil, 4"	983	SY	\$7.73	\$7,598.59
32	Sodding & Fertilizing	983	SY	\$7.00	\$6,881.00
33	Chemical Spray Application	983	SY	\$1.00	\$983.00

Total Base Bid: \$727,760.89

ARTICLE III. UNIT PRICES FOR CHANGES- Not applicable to this contract.

ARTICLE IV. PAYMENTS- Payments are to be made to the Contractor in accordance with and subject to the provisions embodied in the documents made a part of this Contract.

ARTICLE V. CONTRACT TIME- The bidder to whom the Contract is awarded shall commence work no later than the date to begin work set forth in a Notice to Proceed from the City, or its authorized representative, to the Contractor. All work shall be done in strict compliance with the plans and specifications prepared by the Engineer of the Engineering Division of the Public Works Department of Bettendorf, Iowa.

All work on this contract shall be completed by September 26, 2025. The beginning and completion dates will be included in and made part of the Contract. Said completion date will be used as the Contract Completion Date, where after liquidated damages in the amount of Five Hundred Dollars and No Cents (\$500.00) per calendar day may be recovered by the City.

ARTICLE VI. COMPONENT PARTS OF THIS CONTRACT - This contract consists of the following component parts, all of which are as fully a part of this contract as if herein set out verbatim, or, if not attached, as if hereto attached. In the event that any provision in any of the component parts of this contract conflicts with any provision in any other of the component parts, the provision in the first item listed shall control over the second item listed, which shall control over the third item listed, etc.

- 1) Addenda to proposed Contract Documents
- 2) Special Conditions
- 3) Plan Drawings
- 4) Supplemental General Conditions
- 5) General Conditions
- 6) City of Bettendorf Standard Drawings
- 7) City of Bettendorf Standard Specifications
- 8) Iowa D.O.T., AASHTO, ANSI and ASTM Specifications
- 9) Contract With The City
- 10) Contractor's Performance and Payment and Maintenance Bond
- 11) Contractor's Proposal
- 12) Notice To Bidders
- 13) Instruction To Bidders
- 14) Non-Collusion Affidavit

IN WITNESS WHEREOF, the parties hereto have caused this Instrument to be executed in three original counterparts the date and year first above written.

Manatt's, Inc.
(Contractor)

By

Title

ATTEST:

Title

CITY OF BETTENDORF, IA

Robert S. Gallagher
Mayor

ATTEST:

Decker P. Ploehn
City Clerk

This Instrument approved by the City Council of the City of Bettendorf, Iowa, pursuant to Resolution Number _____ passed _____, 2025.

COUNCIL LETTER

MEETING DATE: April 15, 2025
REQUESTED BY: Pat Lynch, P.E., Assistant City Engineer



Item Title

Resolution awarding the contract and approving the contract and bond for the Happy Joe Drive Reconstruction Project.

Explanation

The proposed improvements consist of reconstructing approximately 450 linear feet of twenty-seven foot (27') wide and 370 linear feet of thirty-six foot (36') wide Portland Cement Concrete pavement with new six-inch (6") Portland Cement Concrete (PCC) pavement on a drainable subbase with sub-drains. Also included with this project is the removal and replacement of driveway approaches, storm sewer installation, manhole adjustments, sodding, erosion control, and other work related to reconstructing these streets.

Bids were received on April 8, 2025. Walter D. Laud, Inc. of East Moline, Illinois was the low bidder of nine (9) bids received. Bids ranged from the high of \$521,163.57 to the low of \$386,767.35, which is 14.05% below the engineers estimate of \$450,000.00.

Staff is requesting a contingency be authorized in addition to the low bid total to cover unforeseen changes that may arise during construction. Previous experience indicates poor soils are possible in this area.

If the matter is not budgeted in the current year, explain why funding is requested and the anticipated source:

This project (PW0608) was approved with a total budget of \$450,000 within the Community Improvement Program (CIP).

List Attachments

Resolution; Bid Tabulation; Contract.

RESOLUTION NO. _____-25

**RESOLUTION AWARDING THE CONTRACT AND APPROVING THE CONTRACT AND BOND
FOR THE HAPPY JOE DRIVE RECONSTRUCTION PROJECT**

WHEREAS, plans, specifications, and form of contract were approved by this City Council for the construction of improvements to the street system of said City; namely, the

Happy Joe Drive Reconstruction Project

WHEREAS, bids were accepted for the construction of the above project on the 8th day of April, 2025, with Walter D. Laud, Inc. submitting the lowest responsible quote in the amount of \$386,767.35 and

WHEREAS, appropriately executed contract and bond have been submitted by the Contractor in conformance with the plans and specifications as described above.

NOW, THEREFORE BE IT RESOLVED BY THE CITY COUNCIL OF THE CITY OF BETTENDORF, IOWA, that

1. The bid of Walter D. Laud, Inc. is hereby accepted for the Happy Joe Drive Reconstruction Project in the amount of \$386,767.35.
2. The Mayor and City Administrator are hereby authorized to sign the contract for the construction of said project.
3. The award of contract under this resolution is expressly subject to the bidder providing all necessary bonds and insurance documents; on the bidder's signing of the contract as provided in the form of contract, and no further facts or issues coming to light between the passage of this resolution and the actual signing of the contract by a representative of the City such as would cause the City to reconsider, defer, to stop the decision to enter into the contract.
4. A total purchase order amount of \$450,000.00 which contains the contingency, is hereby approved to cover any unforeseen changes that may arise during construction.

Passed, Approved and Adopted this 15th day of April 2025.

Robert S. Gallagher, Mayor

Attest:

Decker P. Ploehn, City Clerk

Happy Joe Drive Reconstruction Project				Walter D. Laud, Inc.		Hawkeye Paving Corp		N.J. Miller, Inc.		Eastern Iowa Excavating & Concrete, LLC		Phoenix Corporation of the Quad Cities		MIDWEST CONCRETE, INC.		Centennial Contractors		BWC Excavating, LC		LANGMAN CONSTRUCTION, INC.	
Bid Open: April 8, 2025				Total Price	\$386,767.35	Total Price	\$395,457.35	Total Price	\$401,232.00	Total Price	\$417,958.80	Total Price	\$436,996.45	Total Price	\$442,871.95	Total Price	\$443,286.50	Total Price	\$474,332.25	Total Price	\$521,163.57
Line #	Description	QTY	UOM	Unit	Extended	Unit	Extended	Unit	Extended	Unit	Extended	Unit	Extended	Unit	Extended	Unit	Extended	Unit	Extended	Unit	Extended
1	Temporary Traffic Control	1	LS	\$6,000.00	\$6,000.00	\$27,500.00	\$27,500.00	\$10,000.00	\$10,000.00	\$10,250.00	\$10,250.00	\$20,300.00	\$20,300.00	\$12,500.00	\$12,500.00	\$11,000.00	\$11,000.00	\$12,500.00	\$12,500.00	\$10,000.00	\$10,000.00
2	Intake Protection Device, Drop-In	9	EA	\$150.00	\$1,350.00	\$50.00	\$450.00	\$100.00	\$900.00	\$130.00	\$1,170.00	\$75.00	\$675.00	\$77.00	\$693.00	\$150.00	\$1,350.00	\$225.00	\$2,025.00	\$80.00	\$720.00
3	Filter Sock, 12"	1488	LF	\$0.50	\$744.00	\$1.00	\$1,488.00	\$1.00	\$1,488.00	\$2.30	\$3,422.40	\$1.95	\$2,901.60	\$2.00	\$2,976.00	\$1.00	\$1,488.00	\$2.00	\$2,976.00	\$1.25	\$1,860.00
4	Full Depth Saw Cut	99	LF	\$3.00	\$297.00	\$4.00	\$396.00	\$5.00	\$495.00	\$7.00	\$693.00	\$5.00	\$495.00	\$4.00	\$396.00	\$5.00	\$495.00	\$13.00	\$1,287.00	\$4.00	\$396.00
5	Pavement, Driveway, and Sidewalk Removal	3212	SY	\$15.00	\$48,180.00	\$12.00	\$38,544.00	\$14.00	\$44,968.00	\$20.50	\$65,846.00	\$12.50	\$40,150.00	\$13.00	\$41,756.00	\$18.00	\$57,816.00	\$17.50	\$56,210.00	\$20.00	\$64,240.00
6	Remove Intake	4	EA	\$100.00	\$400.00	\$80.00	\$3,200.00	\$50.00	\$2,000.00	\$70.00	\$2,800.00	\$90.00	\$3,600.00	\$50.00	\$2,000.00	\$75.00	\$3,000.00	\$408.00	\$1,632.00	\$1,000.00	\$4,000.00
7	Remove Storm Sewer, RCP, 15"	52	LF	\$25.00	\$1,300.00	\$20.00	\$1,040.00	\$5.00	\$260.00	\$13.00	\$676.00	\$31.50	\$1,638.00	\$12.00	\$624.00	\$20.00	\$1,040.00	\$38.00	\$1,976.00	\$15.00	\$780.00
8	Pipe Foundation Stabilization	10	TON	\$1.00	\$10.00	\$8.00	\$80.00	\$10.00	\$100.00	\$61.25	\$612.50	\$40.00	\$400.00	\$61.00	\$610.00	\$40.00	\$400.00	\$72.00	\$720.00	\$20.00	\$200.00
9	Single Intake, New	2	EA	\$2,500.00	\$5,000.00	\$5,000.00	\$10,000.00	\$4,100.00	\$8,200.00	\$3,650.00	\$7,300.00	\$3,200.00	\$6,400.00	\$3,600.00	\$7,200.00	\$3,500.00	\$7,000.00	\$4,250.00	\$8,500.00	\$6,000.00	\$12,000.00
10	Double Intake, New	2	EA	\$3,750.00	\$7,500.00	\$7,000.00	\$14,000.00	\$6,500.00	\$13,000.00	\$5,425.00	\$10,850.00	\$5,800.00	\$11,600.00	\$5,000.00	\$10,000.00	\$4,500.00	\$9,000.00	\$6,800.00	\$13,600.00	\$8,000.00	\$16,000.00
11	Storm Sewer, Trenched, RCP, 15"	52	LF	\$95.00	\$4,940.00	\$130.00	\$6,760.00	\$95.00	\$4,940.00	\$117.50	\$6,110.00	\$107.50	\$5,590.00	\$102.00	\$5,304.00	\$100.00	\$5,200.00	\$176.00	\$9,152.00	\$100.00	\$5,200.00
12	Intake Repair and Adjust	4	EA	\$1,200.00	\$4,800.00	\$1,200.00	\$4,800.00	\$1,500.00	\$6,000.00	\$1,685.00	\$6,740.00	\$2,500.00	\$10,000.00	\$2,000.00	\$8,000.00	\$1,750.00	\$7,000.00	\$2,000.00	\$8,000.00	\$2,500.00	\$10,000.00
13	Temporary Aggregate Surfacing	110	TON	\$1.00	\$110.00	\$10.00	\$1,100.00	\$35.00	\$3,850.00	\$35.00	\$3,850.00	\$32.00	\$3,520.00	\$32.00	\$3,520.00	\$30.00	\$3,300.00	\$33.00	\$3,630.00	\$25.00	\$2,750.00
14	Subdrain, Perforated, Flexible Drain Tile (4")	1603	LF	\$16.00	\$25,648.00	\$12.00	\$19,236.00	\$12.00	\$19,236.00	\$9.35	\$14,988.05	\$13.50	\$21,640.50	\$19.00	\$30,457.00	\$13.00	\$20,839.00	\$12.00	\$19,236.00	\$20.00	\$32,060.00
15	Granular Stabilization Material	500	TON	\$20.00	\$10,000.00	\$8.00	\$4,000.00	\$25.00	\$12,500.00	\$34.25	\$17,125.00	\$40.00	\$20,000.00	\$35.50	\$17,750.00	\$30.00	\$15,000.00	\$48.00	\$24,000.00	\$25.00	\$12,500.00
16	Subgrade Treatment, Engineering Fabric	825	SY	\$3.00	\$2,475.00	\$2.00	\$1,650.00	\$5.00	\$4,125.00	\$8.00	\$6,600.00	\$2.00	\$1,650.00	\$3.40	\$2,805.00	\$4.00	\$3,300.00	\$3.00	\$2,475.00	\$2.00	\$1,650.00
17	Subbase, Granular, 6" (IDOT GR 12 or 14)	3171	SY	\$13.00	\$41,223.00	\$14.00	\$44,394.00	\$10.50	\$33,295.50	\$9.00	\$28,539.00	\$16.00	\$50,736.00	\$21.50	\$68,176.50	\$10.00	\$31,710.00	\$11.00	\$34,881.00	\$12.32	\$39,066.72
18	Pavement, P.C.C., 6"	3014	SY	\$60.00	\$180,840.00	\$57.00	\$171,798.00	\$63.50	\$191,389.00	\$60.25	\$181,593.50	\$60.50	\$182,347.00	\$55.00	\$165,770.00	\$70.00	\$210,980.00	\$68.50	\$206,459.00	\$85.00	\$256,190.00
19	Driveway, Paved, P.C.C., 6"	116	SY	\$98.00	\$11,368.00	\$82.00	\$9,512.00	\$65.00	\$7,540.00	\$59.85	\$6,942.60	\$90.00	\$10,440.00	\$69.00	\$8,004.00	\$81.00	\$9,396.00	\$62.25	\$7,221.00	\$95.00	\$11,020.00
20	Sidewalk, P.C.C., 4"	853	SF	\$10.00	\$8,530.00	\$14.00	\$11,942.00	\$6.00	\$5,118.00	\$6.75	\$5,757.75	\$9.50	\$8,103.50	\$11.50	\$9,809.50	\$13.00	\$11,089.00	\$6.25	\$5,331.25	\$9.00	\$7,677.00
21	Detectable Warning Surfaces at ADA Curb Ramps	60	SF	\$30.00	\$1,800.00	\$50.00	\$3,000.00	\$45.00	\$2,700.00	\$33.75	\$2,025.00	\$47.00	\$2,820.00	\$34.00	\$2,040.00	\$50.00	\$3,000.00	\$65.25	\$3,915.00	\$87.00	\$5,220.00
22	Sump Drain Connection, Pop-Up Valve	1	EA	\$150.00	\$150.00	\$50.00	\$50.00	\$50.00	\$50.00	\$80.00	\$80.00	\$30.00	\$30.00	\$36.00	\$36.00	\$50.00	\$50.00	\$37.50	\$37.50	\$50.00	\$50.00
23	Downspout Outlet	1	EA	\$200.00	\$200.00	\$50.00	\$50.00	\$50.00	\$50.00	\$825.00	\$825.00	\$300.00	\$300.00	\$260.00	\$260.00	\$500.00	\$500.00	\$375.00	\$375.00	\$500.00	\$500.00
24	Topsoil, Offsite, 4"	1235	SY	\$7.00	\$8,645.00	\$8.00	\$9,880.00	\$7.50	\$9,262.50	\$8.00	\$9,880.00	\$9.00	\$11,115.00	\$11.00	\$13,585.00	\$8.00	\$9,880.00	\$11.00	\$13,585.00	\$8.90	\$10,991.50
25	Sod and Fertilizer	1235	SY	\$7.00	\$8,645.00	\$5.00	\$6,175.00	\$8.00	\$9,880.00	\$10.75	\$13,276.25	\$7.50	\$9,262.50	\$7.75	\$9,571.25	\$8.00	\$9,880.00	\$7.00	\$8,645.00	\$8.00	\$9,880.00
26	Chemical Spray Application	1235	SY	\$0.01	\$12.35	\$0.01	\$12.35	\$1.00	\$1,235.00	\$0.05	\$61.75	\$0.01	\$12.35	\$0.02	\$24.70	\$0.10	\$123.50	\$2.00	\$2,470.00	\$0.01	\$12.35
27	Pavement Markings	1	LS	\$1,200.00	\$1,200.00	\$1,000.00	\$1,000.00	\$1,750.00	\$1,750.00	\$1,400.00	\$1,400.00	\$7,500.00	\$7,500.00	\$6,700.00	\$6,700.00	\$750.00	\$750.00	\$6,500.00	\$6,500.00	\$2,500.00	\$2,500.00
28	Chimney Seals	2	EA	\$1,200.00	\$2,400.00	\$500.00	\$1,000.00	\$1,500.00	\$3,000.00	\$625.00	\$1,250.00	\$1,100.00	\$2,200.00	\$940.00	\$1,880.00	\$1,250.00	\$2,500.00	\$2,278.00	\$4,556.00	\$750.00	\$1,500.00
29	Water Service Pipes (Lower and Replace in kind)	100	LF	\$5.00	\$500.00	\$10.00	\$1,000.00	\$10.00	\$1,000.00	\$61.25	\$6,125.00	\$5.00	\$500.00	\$76.00	\$7,600.00	\$50.00	\$5,000.00	\$71.00	\$7,100.00	\$10.00	\$1,000.00
30	Remove and Replace Monument Mail Box	1	EA	\$2,500.00	\$2,500.00	\$500.00	\$500.00	\$2,000.00	\$2,000.00	\$450.00	\$450.00	\$800.00	\$800.00	\$2,500.00	\$2,500.00	\$750.00	\$750.00	\$5,000.00	\$5,000.00	\$750.00	\$750.00

FORM OF CONTRACT

THIS CONTRACT, made the 15th day of April, 2025, by and between Walter D. Laud, Inc., hereinafter called the "Contractor", and the City of Bettendorf, Scott County, Iowa, hereinafter called the "City",

WITNESSETH, That the Contractor and the City for the consideration stated herein agree as follows:

ARTICLE I. SCOPE OF WORK - The Contractor shall perform everything required to be performed and shall provide and furnish all of the labor, materials, necessary tools, expendable equipment, and all utility and transportation services required to perform and complete in a workmanlike manner all the work required in connection with the construction of the **Happy Joe Drive Reconstruction Project** all in strict accordance with the plans and specifications, including any and all addenda prepared by Engineering Division of the Public Works Department of the City of Bettendorf, Iowa, which plans and specifications are made a part of this contract; and in strict compliance with the Contractor's proposal and the other contract documents herein mentioned which are a part of this contract. The Contractor shall do everything required by this contract and the other documents constituting a part thereof.

ARTICLE II. THE CONTRACT PRICE - The City shall pay to the Contractor for the performance of this contract, subject to any additions or deductions provided therein, in current funds, the contract price of:
Three Hundred Eighty-Six Thousand, Seven Hundred Sixty-Seven Dollars and 35/100 (\$386,767.35)

computed as follows:

Base Bid

Item No.	Description	Units	Quantity	Unit Price	Total Price
1	Temporary Traffic Control	LS	1	\$6,000.00	\$6,000.00
2	Intake Protection Device, Drop-In	EA	9	\$150.00	\$1,350.00
3	Filter Sock, 12"	LF	1488	\$0.50	\$744.00
4	Full Depth Saw Cut	LF	99	\$3.00	\$297.00
5	Pavement, Driveway and Sidewalk Removal	SY	3212	\$15.00	\$48,180.00
6	Remove Intake	EA	4	\$100.00	\$400.00
7	Remove Storm Sewer Pipe, RCP, 15"	LF	52	\$25.00	\$1,300.00
8	Pipe Foundation Stabilization	TON	10	\$1.00	\$10.00
9	Single Intake, New	EA	2	\$2,500.00	\$5,000.00
10	Double Intake, New	EA	2	\$3,750.00	\$7,500.00
11	Storm Sewer, Trenched, RCP, 15"	LF	52	\$95.00	\$4,940.00
12	Intake Repair and Adjust	EA	4	\$1,200.00	\$4,800.00
13	Temporary Aggregate Surfacing	TON	110	\$1.00	\$110.00
14	Subdrain. Perforated, Flexible Drain Tile, 4"	LF	1603	\$16.00	\$25,648.00
15	Granular Stabilization Material	TON	500	\$20.00	\$10,000.00
16	Subgrade Treatment, Engineering Fabric	SY	825	\$3.00	\$2,475.00
17	Subbase, Granular, 6" (IDOT GR 12 or 14)	SY	3171	\$13.00	\$41,223.00
18	Pavement, P.C.C., 6"	SY	3014	\$60.00	\$180,840.00
19	Driveway, Paved, P.C.C., 6"	SY	116	\$98.00	\$11,368.00
20	Sidewalk, P.C.C., 4"	SF	853	\$10.00	\$8,530.00
21	Detectable Warning Surfaces at ADA Curb Ranps	SF	60	\$30.00	\$1,800.00
22	Sump Drain Connection, Pop-Up Valve	EA	1	\$150.00	\$150.00
23	Downspout Outlet	EA	1	\$200.00	\$200.00
24	Topsoil, Off-Site, 4"	SY	1235	\$7.00	\$8,645.00
25	Sod and Fertilizer	SY	1235	\$7.00	\$8,645.00
26	Chemical Spray Application	SY	1235	\$0.01	\$12.35
27	Pavement Markings	LS	1	\$1,200.00	\$1,200.00
28	Chimney Seals	EA	2	\$1,200.00	\$2,400.00
29	Water Service Pipes (Lower and Replace in Kind)	LF	100	\$5.00	\$500.00
30	Remove and Replace Monument Mail Box	EA	1	\$2,500.00	\$2,500.00

Total Base Bid: \$386,767.35

ARTICLE III. UNIT PRICES FOR CHANGES- Not applicable to this contract.

ARTICLE IV. PAYMENTS- Payments are to be made to the Contractor in accordance with and subject to the provisions embodied in the documents made a part of this Contract.

ARTICLE V. CONTRACT TIME- The bidder to whom the Contract is awarded shall commence work on or after April 28, 2025, and no later than the date to begin work set forth in a Notice to Proceed from the City or its authorized representative, to the Contractor. All work shall be done in strict compliance with the plans and specifications prepared by the Engineer of the Engineering Division of the Public Works Department of Bettendorf, Iowa.

All work on this contract shall be completed by August 1, 2025. The beginning and completion dates will be included in and made part of the contract between the successful bidder and the City. Liquidated damages in the amount of Five Hundred Dollars and no/100 (\$500.00) per calendar day shall be charged for every day past the completion date.

ARTICLE VI. COMPONENT PARTS OF THIS CONTRACT - This contract consists of the following component parts, all of which are as fully a part of this contract as if herein set out verbatim, or, if not attached, as if hereto attached. In the event that any provision in any of the component parts of this contract conflicts with any provision in any other of the component parts, the provision in the first item listed shall control over the second item listed, which shall control over the third item listed, etc.

- 1) Addenda to proposed Contract Documents
- 2) Special Conditions
- 3) Plan Drawings
- 4) Supplemental General Conditions
- 5) General Conditions
- 6) City of Bettendorf Standard Drawings
- 7) City of Bettendorf Standard Specifications
- 8) Iowa D.O.T., AASHTO, ANSI and ASTM Specifications
- 9) Contract With The City
- 10) Contractor's Performance and Payment and Maintenance Bond
- 11) Contractor's Proposal
- 12) Notice To Bidders
- 13) Instruction To Bidders
- 14) Non-Collusion Affidavit

IN WITNESS WHEREOF, the parties hereto have caused this Instrument to be executed in three original counterparts the date and year first above written.

Walter D. Laud, Inc.
(Contractor)

By _____

Title

ATTEST:

Title

CITY OF BETTENDORF, IA

Robert S. Gallagher
Mayor

ATTEST:

Decker P. Ploehn
City Clerk

This Instrument approved by the City Council of the City of Bettendorf, Iowa, pursuant to Resolution Number _____ passed _____, 2025.

COUNCIL LETTER

MEETING DATE: April 15, 2025
REQUESTED BY: Brent O. Morlok, P.E. City Engineer



Item Title

Resolution approving an agreement with the Iowa Department of Transportation for intelligent transportation and security system integration for the I-74 Bridge area.

Explanation

The Iowa Department of Transportation (IADOT) has been working with Police and Engineering staff on a potential security system and other intelligent transportation system (ITS) upgrades for the I-74 Bridge area. The security system is targeted towards the area under the bridge that is not currently monitored by other IADOT cameras. Several potential designs and configurations were evaluated, resulting in IADOT soliciting vendors through a Request for Proposals. The design was complicated as it required a single system to be integrated into the two (2) separate and distinct existing camera networks that the City of Bettendorf and the City of Moline currently utilize. Due to that complexity, no proposals were submitted. The group changed course and ultimately agreed that the individual cities would take the lead on their respective sides of the bridge. That arrangement will let each city design and construct a system that fits their needs and works with their existing equipment, but IADOT will fund the work project. Additionally, this agreement permits IADOT to install ITS equipment on City owned traffic signal and light poles near the US67 interchange.

If the matter is not budgeted in the current year, explain why funding is requested and the anticipated source:

There is no cost to the City for the initial installation itself. The City will be responsible for any maintenance, repair or future modifications however.

List Attachments

Resolution; Agreement.

RESOLUTION NO. _____-25

**RESOLUTION APPROVING AN AGREEMENT WITH THE IOWA DEPARTMENT OF
TRANSPORTATION FOR INTELLIGENT TRANSPORTATION AND SECURITY SYSTEM
INTEGRATION FOR THE I-74 BRIDGE AREA**

WHEREAS, the City of Bettendorf and the Iowa Department of Transportation desire to increase security for the I-74 bridge area; and

WHEREAS, the City of Bettendorf supports the installation of a dedicated camera security system; and

WHEREAS, both parties have prepared an agreement to memorialize the conditions and responsibilities of the improvements;

NOW, THEREFORE, BE IT RESOLVED by the City Council of the City of Bettendorf, Iowa, that the Mayor and City Clerk are hereby authorized and directed to execute the agreement.

Passed, Approved and Adopted this 15th day of April, 2025.

Robert S. Gallagher, Mayor

Attest:

Decker P. Ploehn, City Clerk

**IOWA DEPARTMENT OF TRANSPORTATION
Cooperative Agreement**

County	<u>Scott</u>
City	<u>Bettendorf</u>
Project No.	<u>ITS-074-1(221)5--25-82</u>
Iowa DOT	
Agreement No.	<u>2025-16-060</u>
Staff Action No.	<u></u>

This Agreement, is entered into by and between the Iowa Department of Transportation, hereinafter designated the "DOT", and the City of Bettendorf, hereafter designated the "CITY", in accordance with Iowa Code Chapters 28E, 306, 306A and 313.4 as applicable;

The DOT and CITY propose to jointly install, as part of an Intelligent Transportation System (ITS) project, a security system for the I-74 bridge over the Mississippi River and surrounding area; the DOT proposes to share fiber optic cable strands; and

The DOT and CITY are willing to jointly participate in said project, in the manner hereinafter provided; and

The DOT and CITY previously entered into the following ITS agreement: Agreement No. 2006-16-143 for an ITS Network on I-74 within the city of Bettendorf executed by the DOT and the CITY on October 31, 2006 and October 19, 2006; and

This Agreement reflects the current concept of this project which is subject to modification by mutual agreement between the CITY and the DOT; and

Therefore, it is agreed as follows:

1. Project Information

- a. The CITY shall be the lead local governmental agency for carrying out the provisions of this Agreement.
- b. All notices required under this Agreement shall be made in writing to the DOT's and/or the CITY's contact person. The DOT's contact person shall be Tim Simodynes, Assistant Traffic Operations Director. The CITY's contact person shall be Andrew Champion, Administrative Services Police Department.
- c. The CITY shall be responsible for all aspects of the security system project including the design, procurement, installation, integration, operations, and all future maintenance.
- d. The DOT will allow the CITY to use existing conduit and junction boxes on the I-74 bridge, as needed, to provide power and communications to the installed equipment (cameras) for the security system.
- e. The DOT will allow the CITY to use their existing power source located along Isle Parkway near the I-74 bridge at no cost to the CITY for the installed security system equipment.
- f. The CITY will provide, at no cost to the DOT, access to the security system camera video feeds and grants permission for the DOT to record and archive the video feeds.
- g. The DOT will provide to the CITY access to the fiber optic cable installed along the I-74 corridor and bridge. This includes 24 fiber strands (Yellow and Violet fiber tubes) on the I-74 backbone (Link ID 4236) from U.S. 67 north to 53rd Street, and 24 fiber strands (Black and Red fiber tubes) across the I-74 bridges (Link ID 4234 and 4235). The DOT will retain all ownership rights and responsibilities for

all respective strands.

- h. The CITY agrees to not sell or lease any fiber optic strands designated by the DOT to the CITY to a third party, public or private.
- i. The CITY shall, at no cost or obligation to the DOT, allow the DOT to install ITS equipment (camera, radio, etc.) and electrical and/or communication cabling on the CITY owned traffic signal pole at the intersection of U.S. 67 and the I-74 southbound ramps. The CITY will allow the DOT to use their existing power source located within the CITY traffic control cabinet at no cost to the DOT.
- j. The DOT may, with advance notice to the CITY, access the CITY traffic signal control cabinet referenced in Paragraph 1i. of this Agreement for the purpose of establishing electrical service and maintaining DOT ITS devices, electrical service, and equipment within this cabinet.

2. Project Costs

- a. The DOT shall reimburse the CITY for an amount not to exceed \$150,000 towards the costs associated with the procurement, installation, and integration of the security system.
- b. The DOT will reimburse the CITY for contractor provided maintenance of the security system for up to three years if the total project cost does not exceed the maximum allowable reimbursement amount noted in Paragraph 2a.
- c. The CITY shall bear all costs except those specifically allocated to the DOT under the terms of this Agreement.

3. Permits and other Requirements

- a. The CITY shall obtain all necessary permits to perform work within DOT right of way.

4. Project Design and Procurement Method

- a. The CITY or their consultant shall be responsible for the design and system requirements of the security system.
- b. The CITY shall provide plans, specifications, and other related documents for the DOT to review and approve prior to the CITY starting the procurement process. This includes the approval of the location and attachment method of the proposed security system equipment (cameras) on the I-74 bridge.
- c. The procurement method used by the CITY shall be in compliance with applicable laws, ordinances, and administrative rules. The CITY will make a good faith effort to obtain a least three (3) bidders.

5. Ownership and Maintenance

- a. The CITY will be the owner of all new system software, equipment, and hardware installed and required for the security system project.
- b. The CITY shall perform all future maintenance including restoration, relocations, and repairs that may become necessary for the security system on the I-74 bridge.
- c. The CITY understands that they may need to provide protection or full removal of any installed security system related equipment as required for any future DOT projects on the I-74 bridge.
- d. For DOT owned and maintained fiber:

- i. The DOT, or an authorized contractor, shall perform all maintenance on the fiber, including any fiber locating, fiber restoration, fiber relocation, and fiber repairs that may become necessary. The DOT will bear all maintenance related costs.
- ii. In the event of a fiber cut or other need for an emergency repair, upon notification by the DOT to the CITY, the DOT shall commence to respond to correct the interruption in service.
- iii. If the CITY, or a contractor operating under the direction of the CITY, performs any activity, such as but not limited to: splicing, accessing splice cases, or any other procedure that could disrupt the passage of light in the fibers or otherwise impact the DOT's fibers, the activity must be pre-planned five (5) working days in advance and be performed during established DOT approved Maintenance Windows (typically midnight to 6 AM). The five (5) working day notice does not apply to emergency repairs.
- iv. The CITY shall contact the ICN Service Desk at 515-725-4400 or 1-800-572-3940 in the event of a service interruption or to establish all Maintenance Windows to perform any activity that may impact the fiber.

6. Payments and Reimbursements

- a. The CITY shall be responsible for making initial payments to the contractor(s) for all project costs incurred in the development and construction of the project. After payments have been made, the CITY may submit to the DOT periodic itemized claims for reimbursement for eligible project activities.
- b. The DOT shall reimburse the CITY for properly documented and certified claims for eligible project costs.
- c. Upon completion of the project, the CITY shall certify in writing to the DOT that the project activities were completed in substantial compliance with the plans and specifications set out in this Agreement. Final reimbursement of state funds shall be made only after the DOT accepts the project as complete.

7. General Provisions

- a. The DOT will have no liability for any of the CITY installed and owned equipment.
- b. The CITY will have no liability for any of the DOT installed and owned equipment.
- c. To the extent permitted by law, the DOT and CITY shall indemnify and hold each other, their employees and agents, wholly harmless from any damages, claims, demands, or suits by any person or persons to the extent caused by the respective acts or omissions by the DOT or CITY, or the officers, agents, or employees of either, in the course of any work done in connection with any of the matters set forth in this Agreement.
- d. No new legal or administrative entity is created by this Agreement.
- e. No property will be jointly held as part of this Agreement.
- f. Nothing in this Agreement shall be construed to create joint or several liability of a party hereto for the acts, omissions or obligations of the other party. Each party shall be liable only for its own acts and the parties shall have such rights of indemnity and contribution among themselves with respect to this Agreement and the undertakings hereunder as shall be permitted by law and consistent with the provisions of this Agreement.
- g. If any part of this Agreement is found to be void and unenforceable then the remaining provisions of this Agreement shall remain in effect.

- h. This Agreement is not assignable without the prior written consent of the DOT.
- i. It is the intent of both (all) parties that no third-party beneficiaries be created by this Agreement.
- j. This Agreement, as well as the unaffected provisions of any previous agreement(s), addendum(s), and/or amendment(s); represents the entire Agreement between the CITY and DOT regarding this project. All previously executed agreements will remain in effect except as amended herein. Any subsequent change or modification to the terms of this Agreement will be in the form of a duly executed amendment to this document.

IN WITNESS WHEREOF, each of the parties hereto has executed Agreement No. 2025-16-060 as of the date shown opposite its signature below.

CITY OF BETTENDORF:

By: _____ Date _____, 20__.
Mayor

I, _____, certify that I am the Clerk of the City, and that _____, who signed said Agreement for and on behalf of the City was duly authorized to execute the same on the ___ day of _____, 20__.

Signed: _____
City Clerk of Bettendorf, Iowa.

IOWA DEPARTMENT OF TRANSPORTATION:

By: _____ Date _____, 20__.
James R. Schnoebelen, P.E.
District Engineer
District 6

COUNCIL LETTER

MEETING DATE: April 15, 2025
REQUESTED BY: Brian Schmidt, P.E., Director of Public Works



Item Title

Resolution approving the contract extension for the Turf Maintenance Services Contract for City Right-of-Way (Zone 1- 2025).

Explanation

This contract is to provide turf maintenance services (mowing, trimming, and edging) within City right-of-way and/or other locations. The original contract was awarded to A Cut Above Lawn and Landscape, LLC of Davenport Iowa for the 2024 growing season with the option to extend the contract for two (2) years. Staff is requesting to extend services through the 2025 growing season for a total of \$29,040.00.

If the matter is not budgeted in the current year, explain why funding is requested and the anticipated source:

The operating budget has sufficient monies budgeted for the program.

List Attachments

Resolution, Bid Tabulation.

RESOLUTION NO. _____-25

RESOLUTION APPROVING THE CONTRACT EXTENSION FOR THE TURF MAINTENANCE SERVICES CONTRACT FOR CITY RIGHT-OF-WAY (ZONE 1- 2025)

WHEREAS, on the 5th day of March 2024 the City of Bettendorf awarded a contract to A Cut Above Lawn and Landscape, LLC for turf maintenance services (mowing, trimming, and edging) within City right-of-way and/or other locations, and

WHEREAS, the original contract provided the option of two (2) one (1) year contract extensions, and

WHEREAS, staff is requesting to extend the contract for the 2025 growing season in the amount of \$29,040.00.

NOW, THEREFORE BE IT RESOLVED BY THE CITY COUNCIL OF THE CITY OF BETTENDORF, IOWA that the contract extension for the Turf Maintenance Services for City Right-of-Way (Zone 1-2025) is approved, and the Director of Public Works is hereby authorized to issue a purchase order to A Cut Above Lawn and Landscape, LLC in the amount of \$29,040.00.

Passed, Approved and Adopted this 15th day of April, 2025.

Robert S. Gallagher, Mayor

Attest:

Decker P. Ploehn, City Clerk

Turf Maintenance Services Contract for City Right of Way - Zone 1 (2024-2026)

A Cut Above Lawn and Landscape, LLC

Mowing Base Bid

Item	Location	Est. No. of Mows	2024		2025		2026		Cumulative Total
			Unit Price/ mow	Bid Price	Unit Price/ mow	Bid Price	Unit Price/ mow	Bid Price	
1	River Front	30	\$85.00	\$2,550.00	\$88.00	\$2,640.00	\$90.00	\$2,700.00	\$7,890.00
2	Remnant Parcels #1 & #2	30	\$85.00	\$2,550.00	\$88.00	\$2,640.00	\$90.00	\$2,700.00	\$7,890.00
3	Remnant Parcel #3 & IDOT ROW	30	\$40.00	\$1,200.00	\$41.00	\$1,230.00	\$42.00	\$1,260.00	\$3,690.00
4	IDOT right-of-way	30	\$85.00	\$2,550.00	\$88.00	\$2,640.00	\$90.00	\$2,700.00	\$7,890.00
5	Leach Park	30	\$350.00	\$10,500.00	\$360.00	\$10,800.00	\$370.00	\$11,100.00	\$32,400.00
6	Isle of Capri levee	30	\$175.00	\$5,250.00	\$180.00	\$5,400.00	\$185.00	\$5,550.00	\$16,200.00
7	Remnant Parcel #4	30	\$40.00	\$1,200.00	\$41.00	\$1,230.00	\$42.00	\$1,260.00	\$3,690.00
8	Kmberly Rd. medians	30	\$40.00	\$1,200.00	\$41.00	\$1,230.00	\$42.00	\$1,260.00	\$3,690.00
9	Lincoln Rd. Bridge	30	\$40.00	\$1,200.00	\$41.00	\$1,230.00	\$42.00	\$1,260.00	\$3,690.00
2024 Total:			\$28,200.00		2025 Total:	\$29,040.00	2026 Total:	\$29,790.00	\$87,030.00

Lohman Earth Works

Mowing Base Bid

Item	Location	Est. No. of Mows	2024		2025		2026		Cumulative Total
			Unit Price/ mow	Bid Price	Unit Price/ mow	Bid Price	Unit Price/ mow	Bid Price	
1	River Front	30	\$191.10	\$5,733.00	\$210.21	\$6,306.30	\$231.23	\$6,936.90	\$18,976.20
2	Remnant Parcels #1 & #2	30	\$65.00	\$1,950.00	\$71.50	\$2,145.00	\$78.65	\$2,359.50	\$6,454.50
3	Remnant Parcel #3 & IDOT ROW	30	\$95.00	\$2,850.00	\$104.50	\$3,135.00	\$114.95	\$3,448.50	\$9,433.50
4	IDOT right-of-way	30	\$191.10	\$5,733.00	\$210.21	\$6,306.30	\$231.23	\$6,936.90	\$18,976.20
5	Leach Park	30	\$191.10	\$5,733.00	\$210.21	\$6,306.30	\$231.23	\$6,936.90	\$18,976.20
6	Isle of Capri levee	30	\$95.00	\$2,850.00	\$104.50	\$3,135.00	\$114.95	\$3,448.50	\$9,433.50
7	Remnant Parcel #4	30	\$65.00	\$1,950.00	\$71.50	\$2,145.00	\$78.65	\$2,359.50	\$6,454.50
8	Kmberly Rd. medians	30	\$65.00	\$1,950.00	\$71.50	\$2,145.00	\$78.65	\$2,359.50	\$6,454.50
9	Lincoln Rd. Bridge	30	\$65.00	\$1,950.00	\$71.50	\$2,145.00	\$78.65	\$2,359.50	\$6,454.50
2024 Total:			\$30,699.00		2025 Total:	\$33,768.90	2026 Total:	\$37,145.70	\$101,613.60

Simple Turf Lawn Services

Mowing Base Bid

Item	Location	Est. No. of Mows	2024		2025		2026		Cumulative Total
			Unit Price/ mow	Bid Price	Unit Price/ mow	Bid Price	Unit Price/ mow	Bid Price	
1	River Front	30	\$350.00	\$10,500.00	\$360.00	\$10,800.00	\$365.00	\$10,950.00	\$32,250.00
2	Remnant Parcels #1 & #2	30	\$150.00	\$4,500.00	\$160.00	\$4,800.00	\$165.00	\$4,950.00	\$14,250.00
3	Remnant Parcel #3 & IDOT ROW	30	\$200.00	\$6,000.00	\$210.00	\$6,300.00	\$215.00	\$6,450.00	\$18,750.00
4	IDOT right-of-way	30	\$300.00	\$9,000.00	\$310.00	\$9,300.00	\$315.00	\$9,450.00	\$27,750.00
5	Leach Park	30	\$300.00	\$9,000.00	\$310.00	\$9,300.00	\$315.00	\$9,450.00	\$27,750.00
6	Isle of Capri levee	30	\$250.00	\$7,500.00	\$260.00	\$7,800.00	\$265.00	\$7,950.00	\$23,250.00
7	Remnant Parcel #4	30	\$150.00	\$4,500.00	\$160.00	\$4,800.00	\$165.00	\$4,950.00	\$14,250.00
8	Kmberly Rd. medians	30	\$150.00	\$4,500.00	\$160.00	\$4,800.00	\$165.00	\$4,950.00	\$14,250.00
9	Lincoln Rd. Bridge	30	\$100.00	\$3,000.00	\$110.00	\$3,300.00	\$115.00	\$3,450.00	\$9,750.00
2024 Total:			\$58,500.00		2025 Total:	\$61,200.00	2026 Total:	\$62,550.00	\$182,250.00

Brian's Lawn Service

Mowing Base Bid

Item	Location	Est. No. of Mows	2024		2025		2026		Cumulative Total
			Unit Price/ mow	Bid Price	Unit Price/ mow	Bid Price	Unit Price/ mow	Bid Price	
1	River Front	30	\$150.00	\$4,500.00	\$160.00	\$4,800.00	\$175.00	\$5,250.00	\$14,550.00
2	Remnant Parcels #1 & #2	30	\$150.00	\$4,500.00	\$160.00	\$4,800.00	\$175.00	\$5,250.00	\$14,550.00
3	Remnant Parcel #3 & IDOT ROW	30	\$200.00	\$6,000.00	\$210.00	\$6,300.00	\$225.00	\$6,750.00	\$19,050.00
4	IDOT right-of-way	30	\$350.00	\$10,500.00	\$360.00	\$10,800.00	\$375.00	\$11,250.00	\$32,550.00
5	Leach Park	30	\$300.00	\$9,000.00	\$310.00	\$9,300.00	\$325.00	\$9,750.00	\$28,050.00
6	Isle of Capri levee	30	\$300.00	\$9,000.00	\$310.00	\$9,300.00	\$325.00	\$9,750.00	\$28,050.00
7	Remnant Parcel #4	30	\$250.00	\$7,500.00	\$260.00	\$7,800.00	\$275.00	\$8,250.00	\$23,550.00
8	Kmberly Rd. medians	30	\$150.00	\$4,500.00	\$160.00	\$4,800.00	\$175.00	\$5,250.00	\$14,550.00
9	Lincoln Rd. Bridge	30	\$100.00	\$3,000.00	\$110.00	\$3,300.00	\$125.00	\$3,750.00	\$10,050.00
2024 Total:			\$58,500.00		2025 Total:	\$61,200.00	2026 Total:	\$65,250.00	\$184,950.00

Delf's Landscape & Irrigation

Mowing Base Bid

Item	Location	Est. No. of Mows	2024		2025		2026		Cumulative Total
			Unit Price/ mow	Bid Price	Unit Price/ mow	Bid Price	Unit Price/ mow	Bid Price	
1	River Front	30	\$300.00	\$9,000.00	\$315.00	\$9,450.00	\$315.00	\$9,450.00	\$27,900.00
2	Remnant Parcels #1 & #2	30	\$80.00	\$2,400.00	\$80.00	\$2,400.00	\$80.00	\$2,400.00	\$7,200.00
3	Remnant Parcel #3 & IDOT ROW	30	\$150.00	\$4,500.00	\$160.00	\$4,800.00	\$160.00	\$4,800.00	\$14,100.00
4	IDOT right-of-way	30	\$450.00	\$13,500.00	\$475.00	\$14,250.00	\$475.00	\$14,250.00	\$42,000.00
5	Leach Park	30	\$665.00	\$19,950.00	\$700.00	\$21,000.00	\$700.00	\$21,000.00	\$61,950.00
6	Isle of Capri levee	30	\$360.00	\$10,800.00	\$375.00	\$11,250.00	\$375.00	\$11,250.00	\$33,300.00
7	Remnant Parcel #4	30	\$120.00	\$3,600.00	\$120.00	\$3,600.00	\$120.00	\$3,600.00	\$10,800.00
8	Kmberly Rd. medians	30	\$100.00	\$3,000.00	\$100.00	\$3,000.00	\$100.00	\$3,000.00	\$9,000.00
9	Lincoln Rd. Bridge	30	\$100.00	\$3,000.00	\$100.00	\$3,000.00	\$100.00	\$3,000.00	\$9,000.00
2024 Total:			\$69,750.00		2025 Total:	\$72,750.00	2026 Total:	\$72,750.00	\$215,250.00

COUNCIL LETTER

MEETING DATE: April 15, 2025
REQUESTED BY: Brian Schmidt, P.E., Director of Public Works



Item Title

Resolution approving the contract extension for the Turf Maintenance Services Contract for City Right-of-Way (Zone 2- 2025).

Explanation

This contract is to provide turf maintenance services (mowing, trimming, and edging) within City right-of-way and/or other locations. The original contract was awarded to A Cut Above Lawn and Landscape, LLC of Davenport Iowa for the 2024 growing season with the option to extend the contract for two (2) years. Staff is requesting to extend services through the 2025 growing season for a total of \$36,390.00.

If the matter is not budgeted in the current year, explain why funding is requested and the anticipated source:

The operating budget has sufficient monies budgeted for the program.

List Attachments

Resolution, Bid Tabulation.

RESOLUTION NO. _____-25

RESOLUTION APPROVING THE CONTRACT EXTENSION FOR THE TURF MAINTENANCE SERVICES CONTRACT FOR CITY RIGHT-OF-WAY (ZONE 2- 2025)

WHEREAS, on the 5th day of March 2024 the City of Bettendorf awarded a contract to A Cut Above Lawn and Landscape, LLC for turf maintenance services (mowing, trimming, and edging) within City right-of-way and/or other locations, and

WHEREAS, the original contract provided the option of two (2) one (1) year contract extensions, and

WHEREAS, staff is requesting to extend the contract for the 2025 growing season in the amount of \$36,390.00.

NOW, THEREFORE BE IT RESOLVED BY THE CITY COUNCIL OF THE CITY OF BETTENDORF, IOWA that the contract extension for the Turf Maintenance Services for City Right-of-Way (Zone 2-2025) is approved, and the Director of Public Works is hereby authorized to issue a purchase order to A Cut Above Lawn and Landscape, LLC in the amount of \$36,390.00.

Passed, Approved and Adopted this 15th day of April, 2025.

Robert S. Gallagher, Mayor

Attest:

Decker P. Ploehn, City Clerk

Turf Maintenance Services Contract for City Right of Way - Zone 2 (2024-2026)

A Cut Above Lawn and Landscape, LLC

Mowing Base Bid

Item	Location	Est. No. of Mows	2024		2025		2026		Cumulative Total
			Unit Price/ mow	Bid Price	Unit Price/ mow	Bid Price	Unit Price/ mow	Bid Price	
1	Middle Rd under I-74	30	\$175.00	\$5,250.00	\$180.00	\$5,400.00	\$185.00	\$5,550.00	\$16,200.00
2	Spruce Hills Dr.	30	\$130.00	\$3,900.00	\$135.00	\$4,050.00	\$140.00	\$4,200.00	\$12,150.00
3	Middle Rd. & 18th St.	30	\$85.00	\$2,550.00	\$88.00	\$2,640.00	\$90.00	\$2,700.00	\$7,890.00
4	Stafford Blvd.	30	\$85.00	\$2,550.00	\$88.00	\$2,640.00	\$90.00	\$2,700.00	\$7,890.00
5	18th & Tanglefoot Ln.	30	\$40.00	\$1,200.00	\$41.00	\$1,230.00	\$42.00	\$1,260.00	\$3,690.00
6	Crow Creek Rd. medians	30	\$175.00	\$5,250.00	\$180.00	\$5,400.00	\$185.00	\$5,550.00	\$16,200.00
7	53rd St. medians	30	\$445.00	\$13,350.00	\$460.00	\$13,800.00	\$475.00	\$14,250.00	\$41,400.00
8	Welcome to Bettendorf	30	\$40.00	\$1,200.00	\$41.00	\$1,230.00	\$42.00	\$1,260.00	\$3,690.00
2024 Total:			\$35,250.00		2025 Total:	\$36,390.00	2026 Total:	\$37,470.00	\$109,110.00

Lohman Earth Works

Mowing Base Bid

Item	Location	Est. No. of Mows	2024		2025		2026		Cumulative Total
			Unit Price/ mow	Bid Price	Unit Price/ mow	Bid Price	Unit Price/ mow	Bid Price	
1	Middle Rd under I-74	30	\$95.00	\$2,850.00	\$104.50	\$3,135.00	\$114.95	\$3,448.50	\$9,433.50
2	Spruce Hills Dr.	30	\$85.00	\$2,550.00	\$93.50	\$2,805.00	\$102.85	\$3,085.50	\$8,440.50
3	Middle Rd. & 18th St.	30	\$65.00	\$1,950.00	\$71.50	\$2,145.00	\$78.65	\$2,359.50	\$6,454.50
4	Stafford Blvd.	30	\$95.00	\$2,850.00	\$104.50	\$3,135.00	\$114.95	\$3,448.50	\$9,433.50
5	18th & Tanglefoot Ln.	30	\$65.00	\$1,950.00	\$71.50	\$2,145.00	\$78.65	\$2,359.50	\$6,454.50
6	Crow Creek Rd. medians	30	\$307.22	\$9,216.60	\$337.95	\$10,138.50	\$371.75	\$11,152.50	\$30,507.60
7	53rd St. medians	30	\$545.00	\$16,350.00	\$599.50	\$17,985.00	\$659.45	\$19,783.50	\$54,118.50
8	Welcome to Bettendorf	30	\$65.00	\$1,950.00	\$71.50	\$2,145.00	\$78.65	\$2,359.50	\$6,454.50
2024 Total:			\$39,666.60		2025 Total:	\$43,633.50	2026 Total:	\$47,997.00	\$131,297.10

Delf's Landscape and Irrigation

Mowing Base Bid

Item	Location	Est. No. of Mows	2024		2025		2026		Cumulative Total
			Unit Price/ mow	Bid Price	Unit Price/ mow	Bid Price	Unit Price/ mow	Bid Price	
1	Middle Rd under I-74	30	\$175.00	\$5,250.00	\$180.00	\$5,400.00	\$180.00	\$5,400.00	\$16,050.00
2	Spruce Hills Dr.	30	\$150.00	\$4,500.00	\$165.00	\$4,950.00	\$165.00	\$4,950.00	\$14,400.00
3	Middle Rd. & 18th St.	30	\$80.00	\$2,400.00	\$80.00	\$2,400.00	\$80.00	\$2,400.00	\$7,200.00
4	Stafford Blvd.	30	\$240.00	\$7,200.00	\$245.00	\$7,350.00	\$245.00	\$7,350.00	\$21,900.00
5	18th & Tanglefoot Ln.	30	\$80.00	\$2,400.00	\$80.00	\$2,400.00	\$80.00	\$2,400.00	\$7,200.00
6	Crow Creek Rd. medians	30	\$325.00	\$9,750.00	\$340.00	\$10,200.00	\$340.00	\$10,200.00	\$30,150.00
7	53rd St. medians	30	\$480.00	\$14,400.00	\$500.00	\$15,000.00	\$500.00	\$15,000.00	\$44,400.00
8	Welcome to Bettendorf	30	\$80.00	\$2,400.00	\$80.00	\$2,400.00	\$80.00	\$2,400.00	\$7,200.00
2024 Total:			\$48,300.00		2025 Total:	\$50,100.00	2026 Total:	\$50,100.00	\$148,500.00

Simple Turf Lawn

Mowing Base Bid

Item	Location	Est. No. of Mows	2024		2025		2026		Cumulative Total
			Unit Price/ mow	Bid Price	Unit Price/ mow	Bid Price	Unit Price/ mow	Bid Price	
1	Middle Rd under I-74	30	\$350.00	\$10,500.00	\$355.00	\$10,650.00	\$360.00	\$10,800.00	\$31,950.00
2	Spruce Hills Dr.	30	\$300.00	\$9,000.00	\$305.00	\$9,150.00	\$310.00	\$9,300.00	\$27,450.00
3	Middle Rd. & 18th St.	30	\$200.00	\$6,000.00	\$205.00	\$6,150.00	\$210.00	\$6,300.00	\$18,450.00
4	Stafford Blvd.	30	\$200.00	\$6,000.00	\$205.00	\$6,150.00	\$210.00	\$6,300.00	\$18,450.00
5	18th & Tanglefoot Ln.	30	\$200.00	\$6,000.00	\$205.00	\$6,150.00	\$210.00	\$6,300.00	\$18,450.00
6	Crow Creek Rd. medians	30	\$350.00	\$10,500.00	\$355.00	\$10,650.00	\$360.00	\$10,800.00	\$31,950.00
7	53rd St. medians	30	\$550.00	\$16,500.00	\$555.00	\$16,650.00	\$560.00	\$16,800.00	\$49,950.00
8	Welcome to Bettendorf	30	\$150.00	\$4,500.00	\$155.00	\$4,650.00	\$160.00	\$4,800.00	\$13,950.00
2024 Total:			\$69,000.00		2025 Total:	\$70,200.00	2026 Total:	\$71,400.00	\$210,600.00

COUNCIL LETTER

MEETING DATE: April 15, 2025
REQUESTED BY: Brent O. Morlok, P.E., City Engineer



Item Title

Resolution authorizing the Director of Public Works to issue a purchase order to CDW Government for traffic network switches.

Explanation

The Engineering Division annually makes purchases of various traffic related equipment that has exceeded the end of life recommendations, including controllers, battery backups, network switches, etc. This purchase will replace a number of network switches that reside in traffic cabinets. Due to this equipment being located outdoors, the materials must be hardened / rugged and have a shorter lifespan than other electronic equipment located in climate controlled environments.

CDW Government submitted a quote in the amount of \$49,855.00. CDW Government is an approved vendor for the Iowa Cisco NVP Data Communications AR3227 contract pricing group.

If the matter is not budgeted in the current year, explain why funding is requested and the anticipated source:

This project (CD0105) was approved with a total budget of \$50,000.00 within the Community Improvement Program (CIP).

List Attachments

Resolution, Quote.

RESOLUTION NO. _____-25

**RESOLUTION AUTHORIZING THE DIRECTOR OF PUBLIC WORKS TO ISSUE A PURCHASE ORDER
TO CDW GOVERNMENT FOR TRAFFIC NETWORK SWITCHES**

WHEREAS, the City's purchasing policies require that any contract purchases in the amount of \$25,000 or greater be approved by a City Council resolution; and

WHEREAS, the requested network switches are a key component in maintaining the City's traffic signal network; and

WHEREAS, bids were publicly solicited and CDW Government is an approved Iowa Cisco NVP Data Communications vendor and submitted a quote in the amount of \$49,855.00;

NOW, THEREFORE, BE IT RESOLVED by the City Council of the City of Bettendorf, Iowa, that the Director of Public Works is authorized to issue a purchase order to CDW Government in the amount of \$49,855.00.

Passed, Approved and Adopted this 15th day of April 2025.

Robert S. Gallagher, Mayor

Attest:

Decker P. Ploehn, City Clerk



Thank you for choosing CDW. We have received your quote.

Hardware Software Services IT Solutions Brands Research Hub

QUOTE CONFIRMATION

CASEY HOFFMAN,

Thank you for considering CDW•G for your technology needs. The details of your quote are below. **If you are an eProcurement or single sign on customer, please log into your system to access the CDW site.** You can search for your quote to retrieve and transfer back into your system for processing.

For all other customers, click below to convert your quote to an order.

Convert Quote to Order

QUOTE #	QUOTE DATE	QUOTE REFERENCE	CUSTOMER #	GRAND TOTAL
PJZV536	4/7/2025	PJZV536	6941559	\$49,855.00

IMPORTANT - PLEASE READ

Special Instructions: TAX: MULTIPLE TAX JURISDICTIONS APPLY
TAX: CONTACT CDW FOR TAX DETAILS

QUOTE DETAILS

ITEM	QTY	CDW#	UNIT PRICE	EXT. PRICE
Cisco Catalyst IE3300 Rugged Series - Network Essentials - switch - 10 port Mfg. Part#: IE-3300-8T2S-E UNSPSC: 43222612 TAX: BETTENDORF, IA .0000% \$.00 Contract: Iowa Cisco NVP Data Communications AR3227 (AR3227 21294)	8	5460812	\$1,500.00	\$12,000.00
Cisco AC-DC Power Module for POE solution - power adapter - 65 Watt Mfg. Part#: PWR-IE65W-PC-AC TAX: BETTENDORF, IA .0000% \$.00 Contract: Iowa Cisco NVP Data Communications AR3227 (AR3227 21294)	8	5841687	\$300.00	\$2,400.00
Cisco Digital Network Architecture Essentials - Term License (3 years) - 1 Mfg. Part#: IE3300-DNA-E-3Y UNSPSC: 43233204 Electronic distribution - NO MEDIA TAX: BETTENDORF, IA .0000% \$.00 Contract: Iowa Cisco NVP Data Communications AR3227 (AR3227 21294)	8	5617304	\$260.00	\$2,080.00
Cisco Catalyst - expansion module - Gigabit Ethernet x 6 + SFP (mini-GBIC) Mfg. Part#: IEM-3300-6T2S= UNSPSC: 43201404 TAX: BETTENDORF, IA .0000% \$.00 Contract: Iowa Cisco NVP Data Communications AR3227 (AR3227 21294)	8	5663730	\$825.00	\$6,600.00
Cisco - SFP (mini-GBIC) transceiver module - 1GbE Mfg. Part#: GLC-BX-D=	8	1509174	\$800.00	\$6,400.00

QUOTE DETAILS (CONT.)

UNSPSC: 43201553

TAX: BETTENDORF, IA .0000% \$.00

Contract: Iowa Cisco NVP Data Communications AR3227 (AR3227 21294)

<u>Cisco - SFP (mini-GBIC) transceiver module - 1GbE</u>	8	1509177	\$800.00	\$6,400.00
--	---	---------	----------	------------

Mfg. Part#: GLC-BX-U=

UNSPSC: 43201553

TAX: BETTENDORF, IA .0000% \$.00

Contract: Iowa Cisco NVP Data Communications AR3227 (AR3227 21294)

<u>Cisco Smart Net Total Care - extended service agreement</u>	8	5686518	\$1,000.00	\$8,000.00
--	---	---------	------------	------------

Mfg. Part#: CON-SNT-IE33008E

UNSPSC: 81111811

Electronic distribution - NO MEDIA

TAX: BETTENDORF, IA .0000% \$.00

Contract: Iowa Cisco NVP Data Communications AR3227 (AR3227 21294)

<u>Cisco Catalyst 9300 - Network Essentials - switch - 24 ports - managed - ra</u>	1	4708805	\$2,500.00	\$2,500.00
--	---	---------	------------	------------

Mfg. Part#: C9300-24P-E

UNSPSC: 43222612

TAX: BETTENDORF, IA .0000% \$.00

Contract: Iowa Cisco NVP Data Communications AR3227 (AR3227 21294)

<u>Cisco SMARTnet extended service agreement</u>	1	5686283	\$500.00	\$500.00
--	---	---------	----------	----------

Mfg. Part#: CON-SNT-C93002PE

UNSPSC: 81111811

Electronic distribution - NO MEDIA

TAX: BETTENDORF, IA .0000% \$.00

Contract: Iowa Cisco NVP Data Communications AR3227 (AR3227 21294)

<u>Cisco Digital Network Architecture Essentials - Term License (3 years) - 24</u>	1	4756239	\$375.00	\$375.00
--	---	---------	----------	----------

Mfg. Part#: C9300-DNA-E-24-3Y

UNSPSC: 43233204

Electronic distribution - NO MEDIA

TAX: BETTENDORF, IA .0000% \$.00

Contract: Iowa Cisco NVP Data Communications AR3227 (AR3227 21294)

<u>Cisco Config 1 Secondary Power Supply - power supply - hot-plug redundant</u>	1	5428371	\$600.00	\$600.00
--	---	---------	----------	----------

Mfg. Part#: PWR-C1-715WAC-P/2

UNSPSC: 39121004

TAX: BETTENDORF, IA .0000% \$.00

Contract: Iowa Cisco NVP Data Communications AR3227 (AR3227 21294)

<u>Cisco Catalyst 9300 Series Network Module - expansion module - 10 Gigabit S</u>	2	4712833	\$1,000.00	\$2,000.00
--	---	---------	------------	------------

Mfg. Part#: C9300-NM-8X=

UNSPSC: 43201404

TAX: BETTENDORF, IA .0000% \$.00

Contract: Iowa Cisco NVP Data Communications AR3227 (AR3227 21294)

SUBTOTAL	\$49,855.00
SHIPPING	\$0.00
SALES TAX	\$0.00
GRAND TOTAL	\$49,855.00

PURCHASER BILLING INFO	DELIVER TO
Billing Address: CITY OF BETTENDORF ACCTS PAYABLE 1609 STATE ST BETTENDORF, IA 52722-4937 Phone: (563) 344-4055 Payment Terms: Net 30 Days-Govt State/Local	Shipping Address: CITY OF BETTENDORF FORREST MOOK 1609 STATE ST BETTENDORF, IA 52722-4937 Phone: (563) 344-4055 Shipping Method: DROP SHIP-GROUND
	Please remit payments to: CDW Government 75 Remittance Drive Suite 1515 Chicago, IL 60675-1515



Sales Contact Info

Neal Zolt | (866) 843-0749 | nealzol@cdwg.com

Need Help?



My Account



Support



Call 800.800.4239

[About Us](#) | [Privacy Policy](#) | [Terms and Conditions](#)

This order is subject to CDW's Terms and Conditions of Sales and Service Projects at <http://www.cdwg.com/content/terms-conditions/product-sales.aspx>

For more information, contact a CDW account manager.

© 2025 CDW•G LLC, 200 N. Milwaukee Avenue, Vernon Hills, IL 60061 | 800.808.4239

COUNCIL LETTER

MEETING DATE: April 15, 2025
REQUESTED BY: Mark D. Hunt
Community Development Director



Item Title

Resolution establishing fees for mowing and yard sanitation for years 2025 – 2027 and selecting Kimberly's Kleaning as the contractor.

Explanation

The city of Bettendorf uses a private contractor to mow and remove garbage/refuse from private property in violation of the 2021 International Property Maintenance Code, as adopted by the city. Bid forms were mailed to 10 local area contractors; 2 responsive bids were received by the due date. A points system is used to select the main contractor. For April 2025 to April 2027, the main contractor will be Kimberly's Kleaning of Eldridge, Iowa (see Bid Tabulation, Attachment A). Under the oversight of the Code Enforcement Division, the contractor will bring properties found in violation of mowing or yard sanitation regulations into compliance. At the discretion of the Community Development Director, other firms may be used if circumstances dictate.

The maximum hourly rate to be billed to a property owner will be \$38.25 for an operator with hand tools and \$38.25 for an operator with a mower. The contractor's minimum response time shall be 8 hours. In addition, an administrative fee of \$75 will be assessed to the property owner in an effort to recover the staff costs incurred for billing and lien assessment. No more than \$500.00 in charges will be incurred by the city at any single property for any single event, without preapproval from the Community Development Director.

If the matter is not budgeted in the current year, explain why funding is requested and the anticipated source:

Costs are budgeted

List attachments

Resolution; (A) Bid Tabulation

**RESOLUTION ESTABLISHING FEES FOR MOWING AND YARD
SANITATION FOR YEARS 2025 – 2027 AND SELECTING
KIMBERLY’S KLEANING AS THE CONTRACTOR**

NOW, THEREFORE, BE IT RESOLVED BY THE CITY COUNCIL OF THE CITY OF BETTENDORF, IOWA, that the maximum hourly rate to be billed to a property owner, as a result of the city ordering property to be brought into compliance with mowing or yard sanitation regulations, shall be \$38.25 for an operator with hand tools and \$38.25 for an operator with a mower. A separate \$75.00 administrative fee shall be added to the bill on each occurrence to cover the costs of the city’s staff time and enforcement action. No more than \$500.00 in charges shall be incurred by the city at any single property for any single service event, without pre-approval by the Community Development Director.

BE IT FURTHER RESOLVED that Kimberly’s Kleaning of Eldridge, IA shall be the main contractor used by the city to abate properties in violation of mowing and yard sanitation regulations from April 15, 2025, to April 15, 2027. At the discretion of the Community Development Director, the Code Enforcement Division shall be authorized to use other firms if circumstances dictate.

PASSED, APPROVED, AND ADOPTED this 15th day of April, 2025.

Robert S. Gallagher, Mayor

ATTEST:

Decker P. Ploehn, City Clerk

Bid Tabulation
2025-2027 Weed Mowing

<u>CONTRACTOR</u>	Operator w/ <u>Mower</u> per hour	Operator w/ <u>Hand Tools</u> per hour	Response <u>Time</u> (hours)	Points			Final Rating
Kimberly's Kleaning	\$38.25	\$38.25	8	1	1	3	1.6
QC Lawn Works LLC	\$68.00	\$55.00	3	5	4	2	3.6

10 bid forms were mailed out March 4th, 2025, and 2 responsive bids were received by the deadline.

Angela Tomes
Code Enforcement Official

NOTES:

Under the points columns: the first column is for a mower, the second is for hand tools, and the third is for response time (which is the most important). Number 1 is the lowest, number 2 is the second lowest and so on. Take the three point columns for each vendor, add the three amounts together and divide by three for the final rating.

COUNCIL LETTER

MEETING DATE: April 15, 2025
REQUESTED BY: Taylor Beswick, Senior City Planner



Item Title

Resolution certifying to the State Treasurer the actual population of the recently annexed area as determined by the last federal census of that area to the city of Bettendorf, Iowa, pursuant to Iowa Code section 312.3(4).

Explanation

The City Development Board, an agency of the state of Iowa, recently approved the annexation of unincorporated Scott County territory located north of Forest Grove Drive/195 Street, west of Wells Ferry Road, and south of Interstate-80 into the city of Bettendorf.

Iowa Code Section 312.3(4) deals with the apportionment of road use tax funds to cities and counties, specifically when a city has annexed territory since the last federal census. If a city has annexed territory, the Mayor and City Council must certify the population of the annexed territory to the State Treasurer. The apportionment of funds for the city will then be based on this modified population until the next federal census.

The annexed territory contains all of Blocks 1003, 1008, and 1034 which are in Block Group 1, Census Tract 101.03, Scott County, Iowa. The annexed territory only contains Interstate-80 right-of-way in Block 4048 which is in Block Group 4, Census Tract 101.01, Scott County, Iowa. The following Census Blocks and corresponding populations are per the U.S. 2020 Decennial Census return.

- All of Block 1003: Total Population = 0
- All of Block 1008: Total Population = 0
- All of Block 1034: Total Population = 0
- Part of Block 4048: Total Population = 0

Upon approval by the Mayor and City Council, staff requests to send the above information to the office of the State Treasurer.

If the matter is not budgeted in the current year, explain why funding is requested and the anticipated source:

N/A

List attachments

Resolution

RESOLUTION _____ - 25

RESOLUTION CERTIFYING TO THE STATE TREASURER THE ACTUAL POPULATION OF THE RECENTLY ANNEXED AREA AS DETERMINED BY THE LAST FEDERAL CENSUS OF THAT AREA TO THE CITY OF BETTENDORF, IOWA, PURSUANT TO IOWA CODE SECTION 312.3(4)

WHEREAS, the City Development Board, an agency of the state of Iowa, recently approved the annexation of unincorporated Scott County territory, further described in Exhibit A, is located north of Forest Grove Drive/195 Street, west of Wells Ferry Road, and south of Interstate-80 into the city of Bettendorf, Iowa; and

WHEREAS, pursuant to Iowa Code section 312.3(4), the Mayor and City Council are required to certify to the State Treasurer the actual population of the annexed area as determined by the last federal census of that area; and

WHEREAS, the annexed territory contains all of Blocks 1003, 1008, and 1034 which are in Block Group 1, Census Tract 101.03, Scott County, Iowa; and

WHEREAS, the annexed territory only contains Interstate-80 right-of-way in Block 4048 which is in Block Group 4, Census Tract 101.01, Scott County, Iowa; and

WHEREAS, the total population of the annexed area as determined by the 2020 Decennial Census is zero (0).

NOW, THEREFORE, BE IT RESOLVED by the City Council of the city of Bettendorf, Iowa, hereby certifies that the actual population of territory recently annexed into the city of Bettendorf, Iowa, further described in Exhibit A, is zero.

PASSED, APPROVED, AND ADOPTED this 15th day of April, 2025.

Mayor Robert S. Gallagher

ATTEST:

Decker P. Ploehn, City Clerk

EXHIBIT A

Legal Description

ALL OF THE WEST HALF (W ½) OF THE NORTHWEST QUARTER (NW ¼) AND PART OF THE NORTHWEST QUARTER (NW ¼) OF THE SOUTHWEST QUARTER (SW ¼) OF SECTION 6, TOWNSHIP 78 NORTH, RANGE 5 EAST OF THE 5TH PRINCIPAL MERIDIAN AND PART OF THE SOUTHWEST QUARTER OF SECTION 31, TOWNSHIP 79 NORTH, RANGE 5 EAST OF THE 5TH PRINCIPAL MERIDIAN, SCOTT COUNTY, IOWA AND MORE PARTICULARLY DESCRIBED AS FOLLOWS:

BEGINNING AT THE NORTHWEST CORNER OF SAID SECTION 6; THENCE N87°19'32"E, 648.49 FEET; THENCE N2°10'03"W, 182.50 FEET TO THE NORTH RIGHT OF WAY LINE OF INTERSTATE 80; THENCE ALONG SAID NORTH LINE N87°47'53"E, 133.96 FEET; THENCE ALONG SAID NORTH LINE S82°18'49"E, 168.29 FEET; THENCE N87°25'03"E, 222.45 FEET TO THE CENTERLINE OF WELLS FERRY ROAD; THENCE ALONG SAID CENTERLINE S18°46'09"E, 407.67 FEET; THENCE ALONG SAID CENTERLINE 264.51 FEET ALONG A 930.00 FOOT RADIUS CURVE CONCAVE WESTERLY (CHORD BEARING S11°47'34"E, 263.62 FEET); THENCE ALONG SAID CENTERLINE S02°13'33", 1982.61 FEET TO THE CENTERLINE OF FOREST GROVE ROAD; THENCE SOUTHWESTERLY 350.95 FEET ALONG SAID CENTERLINE ON A 7,051.98 FOOT RADIUS CURVE CONCAVE NORTHWESTERLY (CHORD BEARING S55°32'19"W, 350.91 FEET); THENCE ALONG SAID CENTERLINE S57°47'13"W, 543.60 FEET; THENCE ALONG SAID CENTERLINE S58°50'04"W, 206.84 FEET; THENCE ALONG SAID CENTERLINE S65°25'58"W, 218.50 FEET; THENCE ALONG SAID CENTERLINE S84°00'27"W, 174.87 FEET; THENCE N02°14'19"W, 474.45 FEET; THENCE N02°16'14"W, 2462.26 FEET TO THE POINT OF BEGINNING.

DESCRIBED AREA CONTAINS 88.61 ACRES INCLUDING PUBLIC ROAD EASEMENTS, IOWA DOT RIGHT OF WAY, AND IS SUBJECT TO EASEMENTS AND OTHER RESTRICTIONS OF RECORD.

COUNCIL LETTER

MEETING DATE: April 15, 2025
REQUESTED BY: John Byrnes, Parks and Recreation
Director



Item Title

Resolution authorizing the Director of Parks and Recreation to issue a purchase order to BCI Burke Company, LLC for the Ed Scheck Park Playground Equipment Replacement Project.

Explanation

The Playground equipment at Ed Scheck Park is in poor condition and failing. Furthermore, the current equipment doesn't do the park justice as an attractive neighborhood park with modern offerings. I have developed a work plan within our current CIP budget to replace playground equipment methodically considering their condition and ensuring all parts of Bettendorf are being invested in.

This project consists of procurement and installation of a new playground system, the existing mulch surfacing will stay for this project. Park Maintenance crews will remove the existing playground system and prepare the area for the installation of the new equipment to reduce overall construction costs. The new commercial grade playground system will be constructed within the existing play area boundaries and include the installation of equipment footings, drainage materials (if required). This proposal has been designed with a focus on safety and is fully compliant with ASTM F1487 and CPSC playground safety standards.

BCI Burke Company, LLC (Burke) playground equipment has been used in several other city parks and is the playground system proposed to be installed at Ed Scheck Park. Burke is an authorized representative to purchase and install Burke equipment and is a SOURCEWELL cooperative purchasing vendor that has provided a quote in the total amount of \$151,324.20.

The city's purchasing policy allows for purchases to be made through joint purchasing groups without going through a separate bidding process. This would be the proposed process for purchasing this piece of equipment.

If the matter is not budgeted in the current year, explain why funding is requested and the anticipated source:

This project (PK0165) is funded within the Community Improvement Program (CIP) with a budget of \$500,000; \$151,324.20 of which will be used for this project at Ed Scheck Park.

List Attachments

Resolution, Quote, Renderings, Sourcewell Documentation

RESOLUTION _____ - 25

RESOLUTION AUTHORIZING THE DIRECTOR OF PARKS AND RECREATION TO ISSUE A PURCHASE ORDER TO BCI BURKE COMPANY, LLC FOR THE ED SCHECK PLAYGROUND EQUIPMENT REPLACEMENT PROJECT

WHEREAS, the purchase of playground equipment and shelters has been approved within the Community Improvement Program (CIP); and

WHEREAS, the proposed playground equipment meets ADA (Americans with Disabilities Act), CPSC (U.S. Consumer Product Safety Commission), ASTM – F1487 (American Society for Testing and Materials standard for Public Use Playground Equipment), and IPEMA Certification (Internal Play Equipment Manufactures Associations) specifications recommended by staff; and

WHEREAS, BCI Burke Company, LLC (Burke) playground equipment is an approved vendor on the SOURCEWELL cooperative purchasing contract; and

WHEREAS, BCI Burke Company, LLC is an authorized representative to purchase and install Burke equipment.

NOW, THEREFORE BE IT RESOLVED by the City Council of the city of Bettendorf, Iowa, that the Director of Parks and Recreation is hereby authorized and directed to issue a purchase order in the amount of \$151,324.20 for procurement and installation of new playground equipment at Ed Scheck Park located at 4792 Mayfield Drive in Bettendorf, IA.

Passed, Approved and Adopted this 15th day of April, 2025.

Robert S. Gallagher, Mayor

Attest:

Decker P. Ploehn, City Clerk



ESTIMATE

BCI BURKE COMPANY
PO BOX 549
FOND DU LAC, WI 54936-0549

Quote Number 00001267
Created Date 4/1/2025
Expiration Date 5/1/2025
Quote Name Ed Scheck Park
Estimated Burke Equipment Lead Time 6-7 Weeks

Project Information

PROJECT MANAGER

Angie Wolf
awolf@bciburke.com
(319) 899-5313

Member ID: #2110

PROJECT LOCATION

Ed Scheck Park
John Byrnes
2204 Grant Street
Bettendorf, Iowa 52722
United States
jbyrnes@bettendorf.org
(402) 680-4790

Billing & Shipping Information

BILL TO

City of Bettendorf
John Byrnes
1609 State Street
Bettendorf, Iowa 52722
United States
jbyrnes@bettendorf.org
(402) 680-4790

SHIP TO

Ed Scheck Park
John Byrnes
4403 Devils Glen Road
Bettendorf, Iowa 52722
United States
jbyrnes@bettendorf.org
(402) 680-4790

Burke Product Code	Line Item Description	Quantity	Total Price
974-197882-2	Custom Burke Equipment for Ages 2-5, 5-12, and 2-12 Years per Proposal	1.00	\$162,382.00
Discount	15% Sourcewell Discount	1.00	-\$24,357.30
Discount	Early Bird Sale Discount. Orders must be placed by March 31st, 2025, and ship by June 27th, 2025. No exceptions.	1.00	-\$21,040.50
Discount	Courtesy Discount	1.00	-\$11,000.00
Install	Installation of Burke Equipment	1.00	\$42,500.00



ESTIMATE

BCI BURKE COMPANY
PO BOX 549
FOND DU LAC, WI 54936-0549

Quote Number 00001267
Created Date 4/1/2025
Expiration Date 5/1/2025
Quote Name Ed Scheck Park
Estimated Burke Equipment Lead Time 6-7 Weeks

Total Price \$148,484.20
Burke Equipment \$2,840.00
Freight
****Tax Rate Subject to Change****
Grand Total \$151,324.20

Sourcewell Contract #010521-BUR

Payment Terms

1st Deposit Amount \$108,824.20
1st Deposit Due Date Due 30 days after Burke equipment ship date
2nd Deposit Amount \$45,475.00
2nd Deposit Due Date Due 30 days after completion of project

To place an order, please review the Terms of Sale below and sign and return this quote.
If applicable, include a copy of your tax exempt certificate to avoid state/local sales taxes.
Payment by credit card may be accepted; a 4.5% fee will be added per transaction.

Terms of Sale

Acceptance by either a signature or a purchase order based on this quotation indicates that you are in full agreement with all terms and conditions of this quotation including the following:

If a mutually agreed upon contract has been signed, those terms and conditions will supersede these terms and conditions.

Prices are stated in USD and are valid for 30 days. After 30 days, prices are subject to change without notice. Sales tax will be charged unless a copy of a valid Sales tax exemption certificate is presented with order.

Quoted lead times are based on normal production levels. Actual lead times may vary due to quantities ordered, seasonality and higher than normal production levels. Customer will receive an order acknowledgement which will state the anticipated ship date.

Specify all color selections in writing. Any discrepancies that arise due to oral color selections will be the responsibility of the customer. Custom colors, where available, would be an additional charge.

If customer is installing equipment, all equipment is to be installed per manufacturer's instructions and appropriate guidelines such as ASTM and CPSC.

Loss or Damage in Transit: A signed bill of lading is our receipt from a carrier that our shipment to you was complete and in good condition upon arrival. Before you sign, please check the Bill of Lading carefully when the shipment arrives to make sure nothing is missing and there are no damages. Freight terms are FOB Fond du Lac, WI and charges are predicated on all items being ordered and shipped at the same



BCI BURKE COMPANY
PO BOX 549
FOND DU LAC, WI 54936-0549

Quote Number 00001267
Created Date 4/1/2025
Expiration Date 5/1/2025
Quote Name Ed Scheck Park
Estimated Burke Equipment Lead Time 6-7 Weeks

time. Therefore, once the shipment leaves our plant, we are no longer responsible for any damage, loss or shortage.

Installation, site work, building permits, engineered drawings, etc. are not included unless noted in quotation.

Installation Terms:

A. Burke Responsibilities (Applicable if Burke quoted)

Standard Services Include:

- Shipping Notification/Receiving Instructions
- Installation of Equipment and Materials
- Trash Clean Up (Not including cost for Dumpsters and Off-Site Trash Disposal unless noted)
- All Burke Structure shipments include a FREE Maintenance Kit (Includes Installation Booklet, Graffiti Remover, Tools and Touch Up Paint).

B. Optional Responsibilities (Must be clearly outlined in the applicable Burke quotation/contract):

- Removal of Existing Equipment.
- Underground Utility Check.
- Accept Delivery and Unload Equipment.
- Site Preparation and Grading, Drainage Systems, etc.
- Engineered Drawings for Purchased Equipment.
- Other Permits or Engineered Drawings (i.e. zoning permits, environmental permits, site surveys, etc.).
- Provision of Temporary Fencing.

*All other responsibilities must be clearly outlined in the applicable quotation/contract.

Customer Responsibilities (Applicable if BCI Burke is NOT quoting installation):

- Trash Disposal - Dumpsters or Off Site Disposal.
- Underground Utility Check.
- Accept Delivery and Unload Equipment.
- Provide Area for Storage and Staging.
- Provide Temporary Fencing.
- Secure Site and Equipment.
- Provide Access as Outlined below.

Building Permits

Building permits are the responsibility of the owner. If a building permit is required for your project, there will be an administrative, expeditor, and application fee included on project quote. This fee does not include the cost of the actual permit. Customer will be charged "actual permit" cost on final invoice.

NOTE - All zoning, planning, environmental, etc. permits and approvals are the responsibility of others.

Other Notes:

Access/Utilities. Access must be provided to the installation area for heavy trucks and equipment. Access of equipment and personnel is the obligation of the customer to provide until the project is fully completed. We will take every precaution to avoid damage, however any damage caused by the normal installation of our product, such as sod, concrete sidewalks, private underground utilities, etc., will be the responsibility of the customer, as will any additional costs associated with limiting damage such as providing plywood over sod for access. If access is not reasonably close to the jobsite, any additional costs incurred due to having to transport materials and/or supplies will be the responsibility of the customer.

Rock/Foreign Object Clause. Most installations require digging of holes and footing equipment in concrete below finished grade. Removal of existing ground covers such as asphalt, concrete, tan bark, sand, pea gravel, wood fiber, rubber matting, poured-in-place rubber surfacing, or any other material that interferes or delays the digging of holes, is the responsibility of others, unless otherwise noted. If excessive underground obstructions such as rock, coral, asphalt, concrete, pipes, drainage systems, root systems, water, or any other unknown obstructions are discovered, charges will be added to the original proposal.



ESTIMATE

BCI BURKE COMPANY
PO BOX 549
FOND DU LAC, WI 54936-0549

Quote Number	00001267
Created Date	4/1/2025
Expiration Date	5/1/2025
Quote Name	Ed Scheck Park
Estimated Burke Equipment Lead Time	6-7 Weeks

Playground Surfacing. All playground equipment is to be installed in conjunction with safety surfacing per CPSC guidelines and ASTM standards. If the customer contracts for something contrary to the guidelines, they are accepting all responsibility for any liability and future litigation that may arise.

Acceptance

ACCEPTED & APPROVED

The undersigned hereby agrees to the charges listed in this quotation and to the attached terms and conditions. An order will be placed in accordance to this quotation unless otherwise noted.

Signed: _____ Dated: _____

Print Full Name & Title _____



4792 Mayfield Dr | Bettendorf, IA 52722

March 26, 2025

John Byrnes
City of Bettendorf
2204 Grant St
Bettendorf, IA 52722-5022

Dear John Byrnes:

BCI Burke Company is delighted to provide the City of Bettendorf with this playground equipment proposal.

This design was developed with your specific needs in mind, and we look forward to discussing this project further with you to ensure your complete satisfaction. BCI Burke Company is confident that this proposal will satisfy the City of Bettendorf's functional, environmental, and safety requirements -- and, most importantly -- bring joy and excitement to the children and families directly benefiting from your new playground.

You have our personal commitment to support this project and your organization in every manner possible, and we look forward to developing a long-standing relationship with the City of Bettendorf. We appreciate your consideration and value this opportunity to earn your business.

Sincerely,

Angie Wolf
Sales Representative

BCI Burke Company
P.O. Box 549
Fond du Lac, WI 54937
www.bciurke.com

Phone: 319-899-5313
awolf@bciburke.com

COOPERATIVE PURCHASING OPTIONS

PLAYGROUNDS WITHOUT ALL THE PAPERWORK

Purchasing with contracts may sound intimidating, but getting your community playspace doesn't need to be a painful process of writing specifications, issuing RFP's and jumping through hoops – it can be simplified – we promise! As you continue planning for your new playground, review the Purchasing Contracts offered through our partners.

EQUALIS GROUP

Equalis is an innovative cooperative purchasing organization that believes in the power of partnership and that when you work together you achieve more. The basic premise of the Equalis cooperative purchasing organization is to leverage the combined buying power of all members for better pricing and favorable contract terms. Equalis Group uses the lead agency model for competitively bid contracts, provides our participants the savings they expect and offers efficiencies and peace of mind within the procurement process. It is our mission to continuously improve the measurable and meaningful impact of cooperative services for everyone throughout the supply chain.

GOVMVMT

GOVMVMT is a non-profit group purchasing organization that meets the highest industry standards while putting the public's interest at the forefront of everything they do. Each one of GOVMVMT's first-class suppliers has consciously joined their mission to create the most credible, ethical, and public agency-focused non-profit cooperative purchasing program in the country.

GSA

Federal parks, child development programs, military bases and other agencies are a major priority for BCI Burke, and agencies can purchase Burke playgrounds through Burke's GSA contract for installation virtually anywhere in the world.

OMNIA PARTNERS

OMNIA Partners, Public Sector (Subsidiary National IPA) is the largest and most experienced organization in purchasing and supply chain management. Comprised of participants and suppliers in the public sector, we bring together industry-leading buying power and world-class suppliers to offer an extensive portfolio of competitively solicited and publicly awarded contracts and partnerships. OMNIA Partners is proud to offer more value and resources to state and local government, higher education, K-12 education and non-profits.

SOURCEWELL

As a leader in cooperative purchasing, Sourcewell is passionate about helping members fulfill their public service missions. Sourcewell builds strong relationships with members and vendors to develop practical solutions together.

The easiest way to Join Our Movement is to call your local Representative at 800.266.1250 or visit bciburke.com/rep. Our passion is bringing play to communities like yours and we can't wait to help you get started!



FEATURED PLAY EVENTS

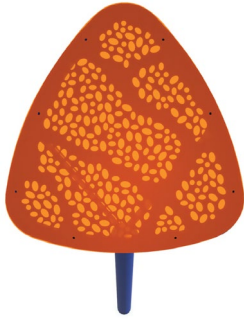

Solis Hue Topper

The beautiful Solis Toppers draw your eye to the sky for interesting shapes and colors and then back down to the ground for unique shadow patterns, bringing us back to nature and natural shapes!



CRESCENT RAIN PANEL

Create the perfect play area for children with Burke's Interactive Play Panels. The play panels encourage exploration and interaction and develop fine motor skills for children with all abilities.



VIPER® SLIDE

The Viper Slide can't be tamed, but kids love trying! Viper's exciting twisty and fast serpentine action is guaranteed to generate incredible high-energy fun and safe, healthy play.

FEATURED PLAY EVENTS



Solis Topper

The beautiful Solis Toppers draw your eye to the sky for interesting shapes and colors and then back down to the ground for unique shadow patterns, bringing us back to nature and natural shapes!



Viper Slide

The Viper Slide can't be tamed, but kids love trying! Viper's exciting twisty and fast serpentine action is guaranteed to generate incredible high-energy fun and safe, healthy play.

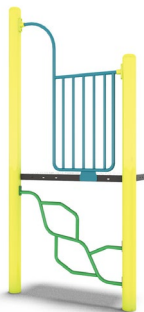

Shasta Climber

Climbers provide several developmental benefits to children, such as building upper body strength along with boosting balance and coordination while they play.

FEATURED PLAY EVENTS



CONTOUR™ SLIDE

The Contour™ Slide offers the ability for kids to slide together and get a sensory experience all in one place. As they slide, kids can put their hands in the middle to feel how the contours change on the way down!



Petal Step Climber

Climbers provide several developmental benefits to children, building upper body strength along with boosting balance and coordination while they play.

DESIGN SUMMARY

BCI Burke Company is very pleased to present this Proposal for consideration for the Ed Scheck Park located in Bettendorf. BCI Burke Company, LLC has been providing recreational playground equipment for over 100 years. It has developed the right mix of world-class capabilities to meet the initial and continuing needs of the City of Bettendorf. We believe our proposal will meet or exceed your project's requirements and will deliver the greatest value to you.

The following is a summary of some of the key elements of our Proposal:

- Project Name: Ed Scheck Park
- Project Number: 974-197882-2
- User Capacity: 122
- Age Groups: 5 to 12, 2 to 5, 2 to 12
- Dimensions: 84' 1"x61' 1"
- Designer Name: Margaret Dechant

BCI Burke Company has developed a custom playground configuration based on the requirements they have presented for the Ed Scheck Park playground project. Our custom design will provide a safe and affordable playground environment that is aesthetically pleasing, full of fun for all users, and uniquely satisfies your specific requirements. In addition, proposal # 974-197882-2 has been designed with a focus on safety and is fully compliant with ASTM F1487 and CPSC playground safety standards.

We invite you to review this proposal for the Ed Scheck Park playground project and to contact us with any questions that you may have.

Thank you in advance for giving us the opportunity to make this project a success.

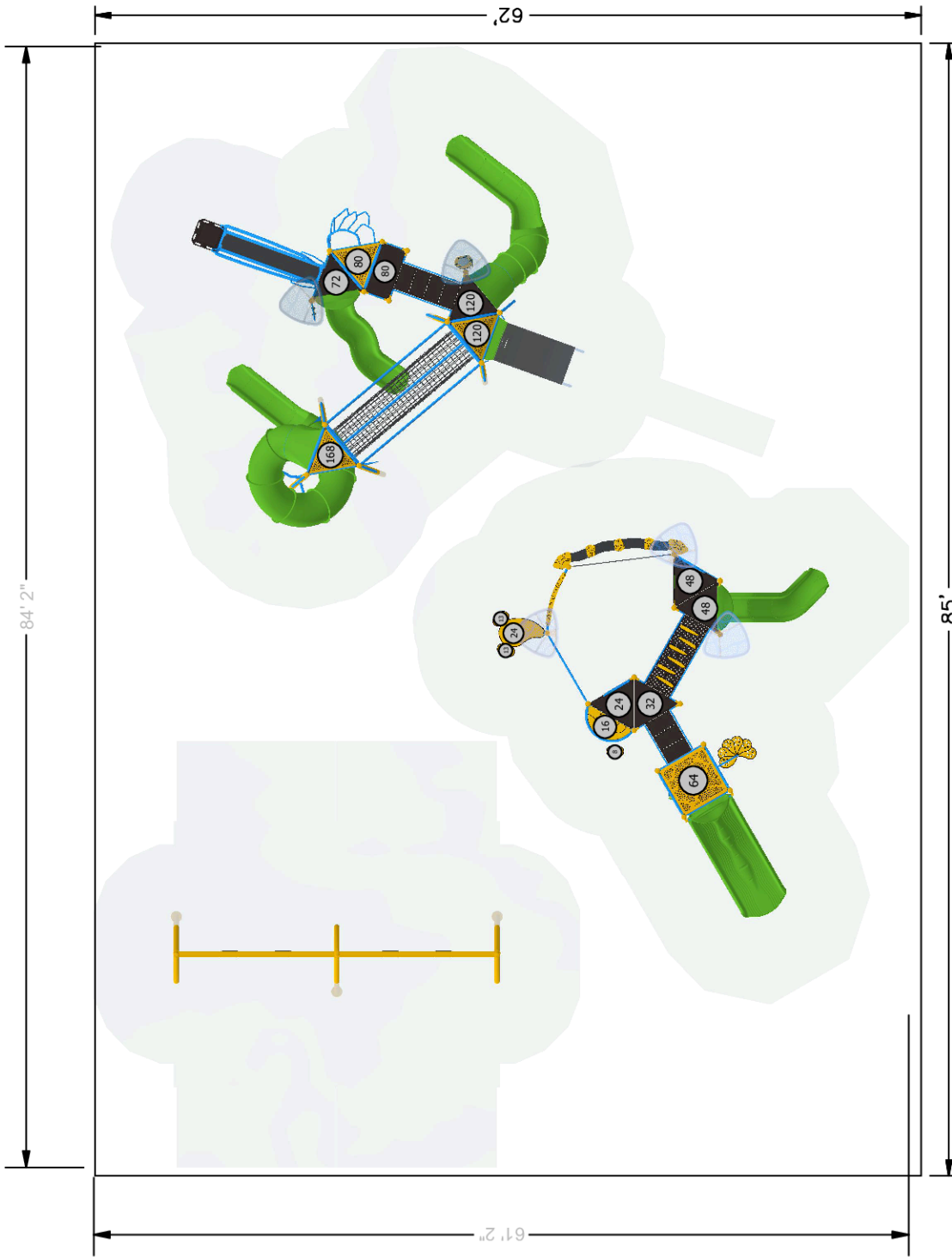

Area = 5270 Sq. Ft.

NOTE: ALTHOUGH ALL ATTEMPTS HAVE BEEN MADE TO PROVIDE AN ACCURATE SITE IT MAY NOT TRULY REPRESENT THE AREA WHERE THIS STRUCTURE IS TO BE PLACED.



OVERALL BOUNDING OF USE ZONES **The space requirements shown here are to ASTM standards. Requirements for other standards may be different.

Area: 5144.6 sq. ft.
 Perimeter: 290.6 ft.
STRUCTURE SIZE: 2" x 84' 2"
POST SIZE (S¹):

PLAYGROUND ACCESSIBILITY (Provided/Required)

TOTAL ELEVATED EVENTS	TRANSFER ACCESSIBLE EVENTS	RAMP ACCESSIBLE EVENTS	GROUND EVENTS	TYPES OF GROUND EVENTS
38	14 / 7	0 / 0	10 / 5	7 / 3

The use and layout of play components identified in this plan conform to the CPSC guidelines. U.S. CPSC recommends the separation of age groups in playground layouts.

SERIES Nucleus | Burke Basics

GROUP:
 NU-3437|NU-3689|Freestanding

DESIGNED FOR AGES:
 5 to 12, 2 to 5, 2 to 12

Ed Scheck Park
 Bettendorf, IA 52722



SITE PLAN VIEW

03/26/2025

BCI Burke Company
 974-197882-2

Designer: Margaret Dechant

Warning: Accessible safety surfacing material is required beneath and around this equipment that is compliant with ASTM, CPSC, and ADAAG requirements.

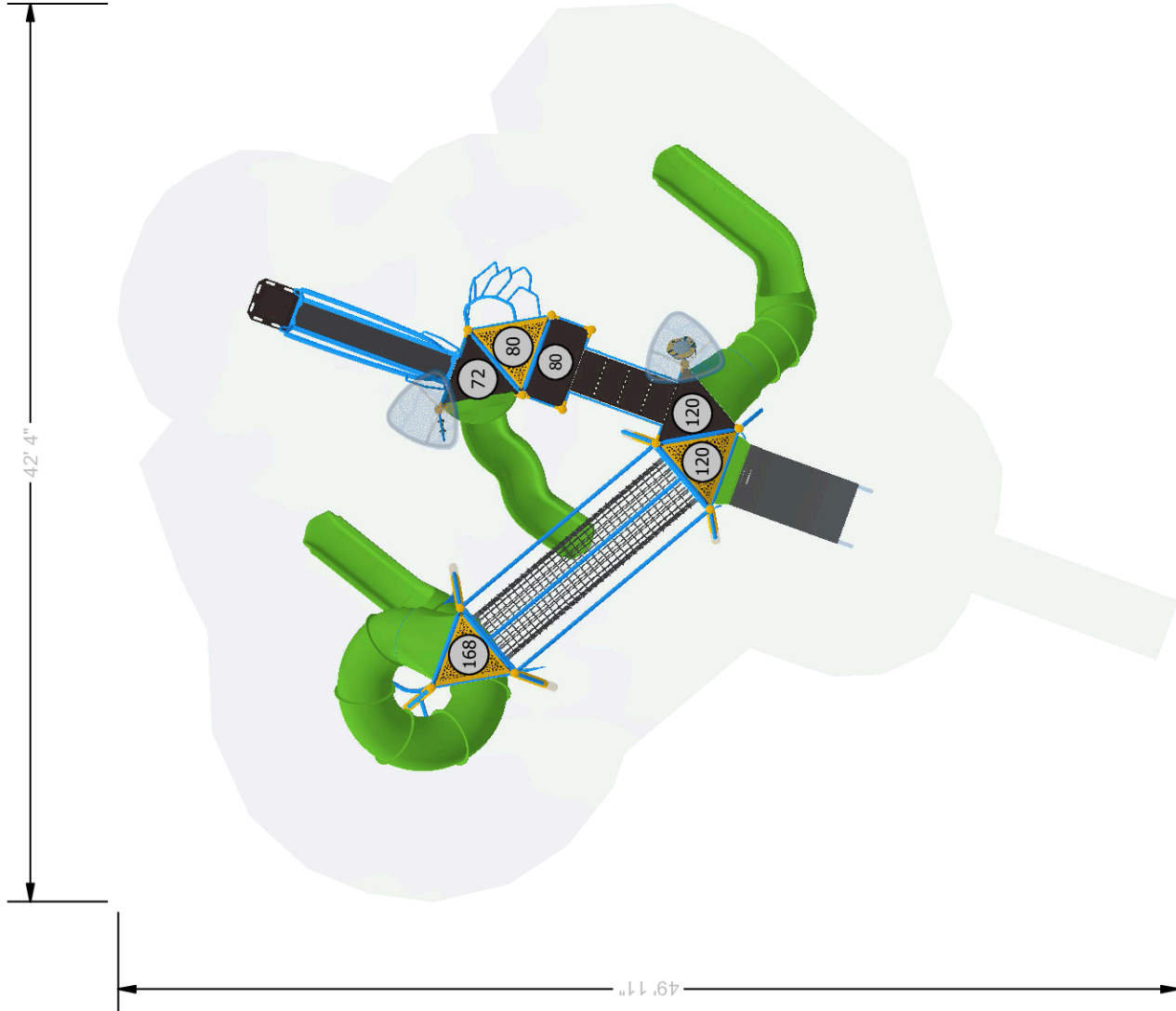

The use and layout of play components identified in this plan conform to the CPSC guidelines. U.S. CPSC recommends the separation of age groups in playground layouts.

PLAYGROUND ACCESSIBILITY (Provided/Required)			
TOTAL ELEVATED EVENTS	TRANSFER ACCESSIBLE EVENTS	RAMP ACCESSIBLE EVENTS	TYPES OF GROUND EVENTS
38	14 / 7	0 / 0	10 / 5 / 7 / 3

OVERALL BOUNDING OF USE ZONES **The space requirements shown here are to ASTM standards. Requirements for other standards may be different.

Area: 5144.6 sq. ft.
 Perimeter: 290.6 ft.
STRUCTURE SIZE: 2" x 84' 2"
POST SIZE(S):

Warning: Accessible safety surfacing material is required beneath and around this equipment that is compliant with ASTM, CPSC, and ADAAG requirements.

SERIES Nucleus	Ed Scheck Park Bettendorf, IA 52722	03/26/2025
GROUP: NU-3437		BCI Burke Company 974-197882-2
DESIGNED FOR AGES: 5 to 12		Designer: Margaret Dechant
BCI BURKE COMPANY, LLC PO BOX 549 FOND DU LAC, WI 54936-0549 920.921.9220 BCIBURKE.COM		

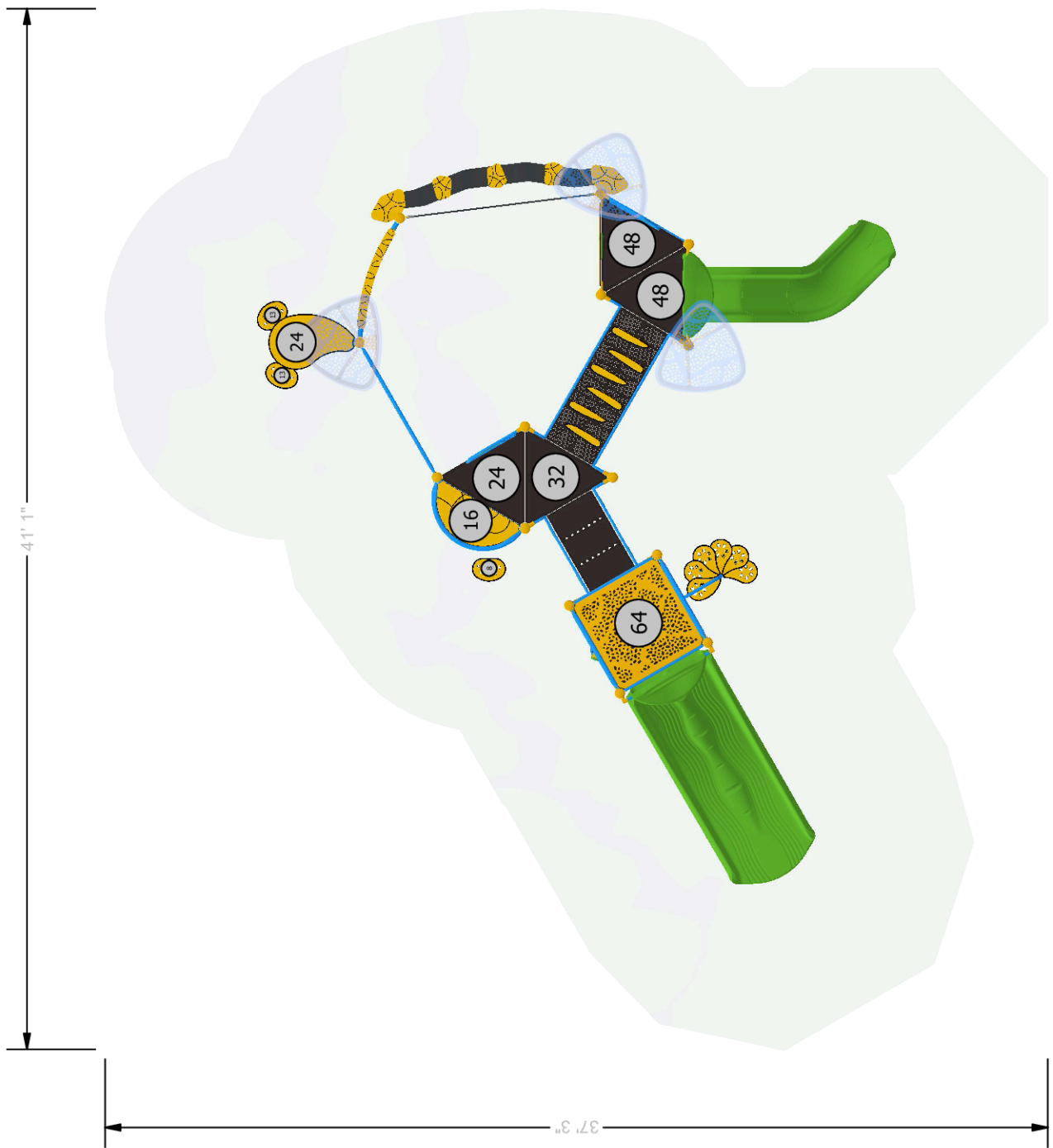

The use and layout of play components identified in this plan conform to the CPSC guidelines. U.S. CPSC recommends the separation of age groups in playground layouts.

PLAYGROUND ACCESSIBILITY (Provided/Required)			
TOTAL ELEVATED EVENTS	TRANSFER ACCESSIBLE EVENTS	RAMP ACCESSIBLE EVENTS	TYPES OF GROUND EVENTS
38	13 / 0	0 / 0	10 / 5 / 7 / 3

OVERALL BOUNDING OF USE ZONES **The space requirements shown here are to ASTM standards. Requirements for other standards may be different.

Area: 5144.6 sq. ft.
 Perimeter: 290.6 ft.
STRUCTURE SIZE: 2" x 84' 2"
POST SIZE (S_T):

Warning: Accessible safety surfacing material is required beneath and around this equipment that is compliant with ASTM, CPSC, and ADAAG requirements.

SERIES Burke Basics Nucleus		SITE PLAN VIEW	
GROUP: NU-3689	Ed Scheck Park Bettendorf, IA 52722	03/26/2025	
DESIGNED FOR AGES: 2 to 5	Burke PLAY THAT MOVES YOU.	BCI Burke Company 974-197882-2	
		Designer: Margaret Dechant	
BCI BURKE COMPANY, LLC PO BOX 549 FOND DU LAC, WI 54936-0549 920.921.9220 BCIBURKE.COM			

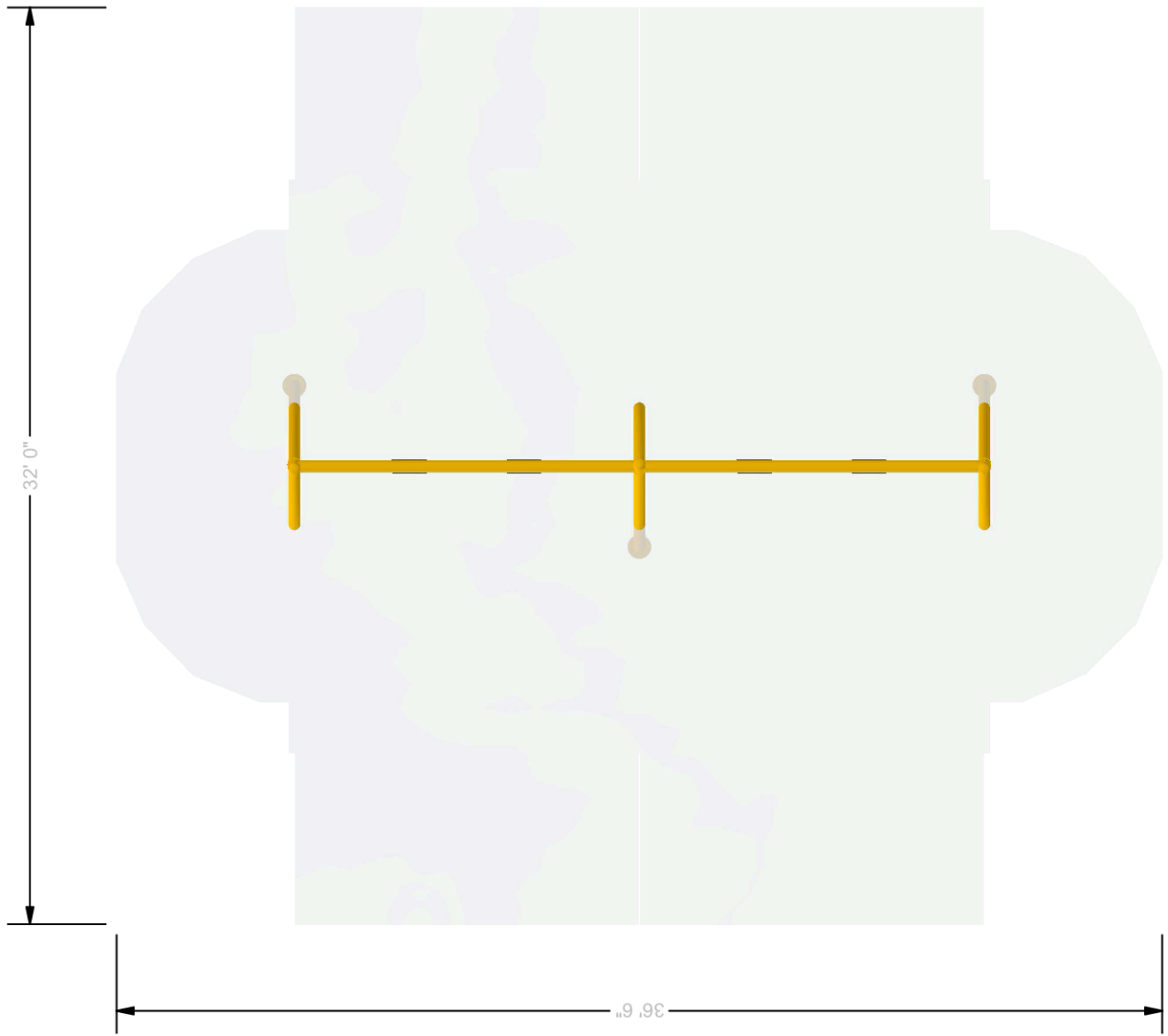

The use and layout of play components identified in this plan conform to the CPSC guidelines. U.S. CPSC recommends the separation of age groups in playground layouts.

PLAYGROUND ACCESSIBILITY (Provided/Required)				
TOTAL ELEVATED EVENTS	TRANSFER ACCESSIBLE EVENTS	RAMP ACCESSIBLE EVENTS	GROUND EVENTS	TYPES OF GROUND EVENTS
38	14 / 7	13 / 0	0 / 0	10 / 5 / 7 / 3

OVERALL BOUNDING OF USE ZONES **The space requirements shown here are to ASTM standards. Requirements for other standards may be different.

Area: 5144.6 sq. ft.
 Perimeter: 290.6 ft.
STRUCTURE SIZE: 2" x 84' 2"
POST SIZE(S):

Warning: Accessible safety surfacing material is required beneath and around this equipment that is compliant with ASTM, CPSC, and ADAAG requirements.

SERIES Burke Basics		SITE PLAN VIEW	
GROUP: Freestanding	Ed Scheck Park Bettendorf, IA 52722	03/26/2025	
DESIGNED FOR AGES: 2 to 12	Burke PLAY THAT MOVES YOU.	BCI Burke Company 974-197882-2	
		Designer: Margaret Dechant	
BCI BURKE COMPANY, LLC PO BOX 549 FOND DU LAC, WI 54936-0549 920.921.9220 BCIBURKE.COM			

ITEM	COMP.	DESCRIPTION
1	270-0129	TRIANGLE PLATFORM
2	470-0760	SOLIS HUE POST TOPPER
3	570-2707	RAIN CRESCENT PANEL
4	270-0009	8" CLOSURE PLATE, ELLIPSE
5	270-0290	HALF PLATFORM
6	570-0072	EVOLUTION HALF BARRIER
7	370-0041	EVOLUTION 40" TRANSITION STAIR W/ BARRIERS
8	570-0001	ASPIRE SMALL WING
9	570-2732	PLAYENSEMBLE BABEL DRUM
10	370-0224	VICTORY CLIMBER
11	670-0007	ASPIRE BIPOD CONNECTOR
12	570-1544	EVOLUTION SHORT CURVED TOP BARRIER
13	370-0068	ASPIRE ROPE TUNNEL
14	570-0002	ASPIRE MEDIUM WING
15	470-0130	ASPIRE COBRA 168"
16	570-1545	EVOLUTION 6' OPENING BARRIER
17	670-0006	ASPIRE TRIPOD CONNECTOR
18	470-0017	EVOLUTION TRIANGLE APEX ROOF
19	470-0811	EVOLUTION ROOF END PLATE
20	470-0008	EVOLUTION SIDE ROOF SUPPORT, LEFT
21	470-0006	EVOLUTION BOTTOM ROOF SUPPORT, SINGLE
22	470-0009	EVOLUTION SIDE ROOF SUPPORT, RIGHT
23	470-0353	COBRA SLIDE FUSION LEFT 120"
24	370-1721	TON CLIMBER 64"-80"
25	270-0122	EVOLUTION OFFSET ENCLOSURE
26	370-1729	360 LOOP CLIMBER
27	270-0120	EVOLUTION UNITARY ENCLOSURE
28	470-0850	CSA VIPER S 64-72 W/O HOOD
29	470-0805	SLIDE HOOD, HIGH SIDE WALL

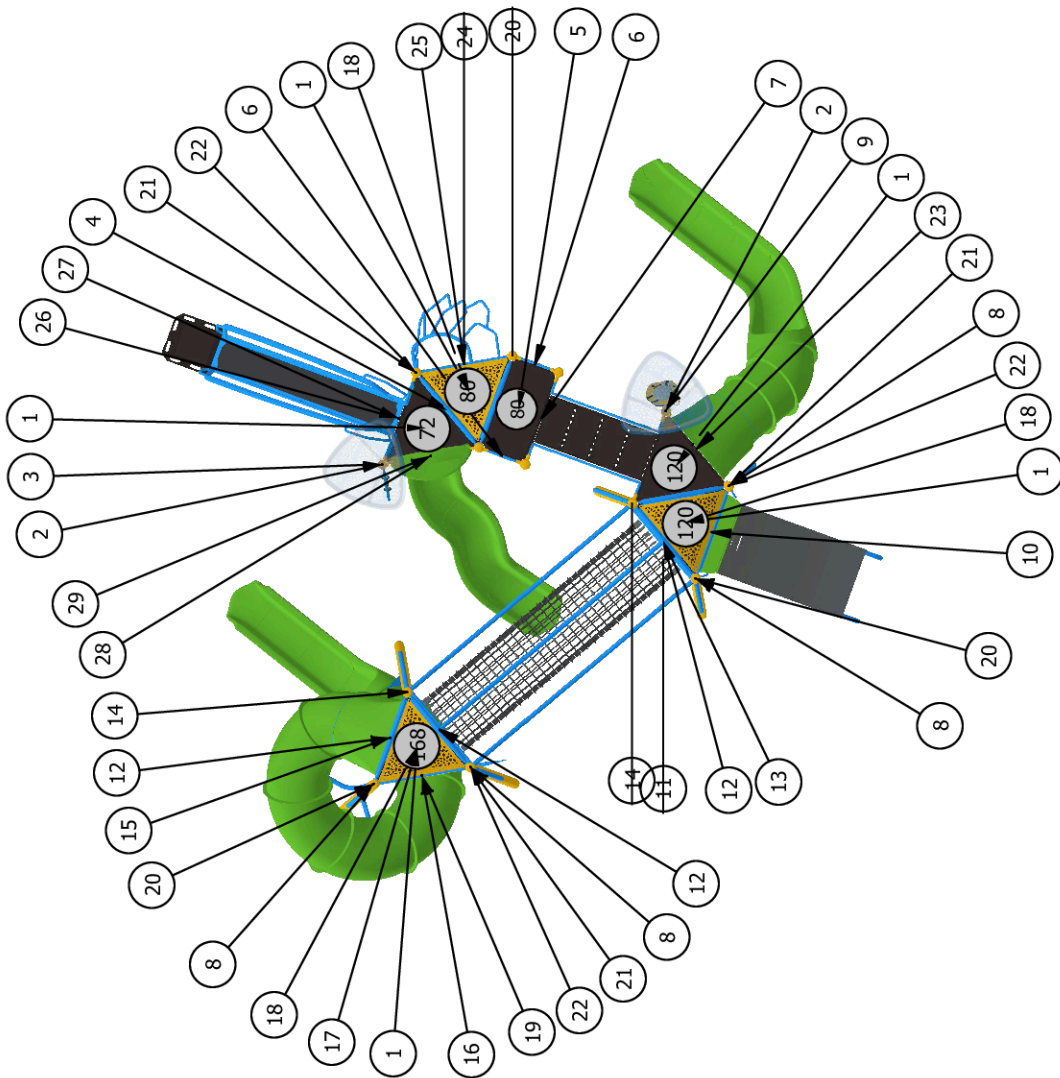

SERIES Nucleus

GROUP:
NU-3437

DESIGNED FOR AGES:
5 to 12

Ed Scheck Park
Bettendorf, IA 52722

Burke
PLAY THAT MOVES YOU

COMPONENT VIEW

03/26/2025

BCI Burke Company
974-197882-2

Designer: Margaret Dechant

ITEM	COMP.	DESCRIPTION
1	580-1364	LIL. NOVO BEAN STEP
2	270-0129	TRIANGLE PLATFORM
3	370-0203	LINX CLIMBER
4	580-1370	NUCLEUS LIL. NOVO BEAN TABLE
5	470-0764	SOLIS POST TOPPER
6	580-1355	LIL. NOVO BEAN BENCH
7	370-0210	TERREX CLIMBER
8	470-0660	VIPER L 48-56 W/O HOOD
9	470-0805	SLIDE HOOD, HIGH SIDE WALL
10	370-0181	PATHWAY LINK, POST TO POST
11	370-1739	LIL. NOVO BALANCE BEAM POST TOPOST
12	370-1664	SHASTA CLIMBER, 40"-48"
13	270-0122	EVOLUTION OFFSET ENCLOSURE
14	570-2736	PISTON PANEL
15	270-0009	8" CLOSURE PLATE, ELLIPSE
16	370-0040	EVOLUTION 32" TRANSITION STAIR W/ BARRIERS
17	270-0130	SQUARE PLATFORM
18	570-0130	EVOLUTION BARRIER W/ KALEIDOSCOPE
19	470-0803	CONTOUR SLIDE, 64"-72"
20	370-1673	PETAL STEP CLIMBER 64"-72"
21	270-0121	EVOLUTION STANCHION
22	470-0980	NICHE CAPSULE NANO, 64"
23	470-0015	EVOLUTION SQUARE ROOF
24	470-0006	EVOLUTION BOTTOM ROOF SUPPORT, SINGLE
25	470-0008	EVOLUTION SIDE ROOF SUPPORT, LEFT
26	470-0003	EVOLUTION TOP ROOF SUPPORT, SINGLE
27	470-0009	EVOLUTION SIDE ROOF SUPPORT, RIGHT
28	470-0075	CRESCENT PLATFORM

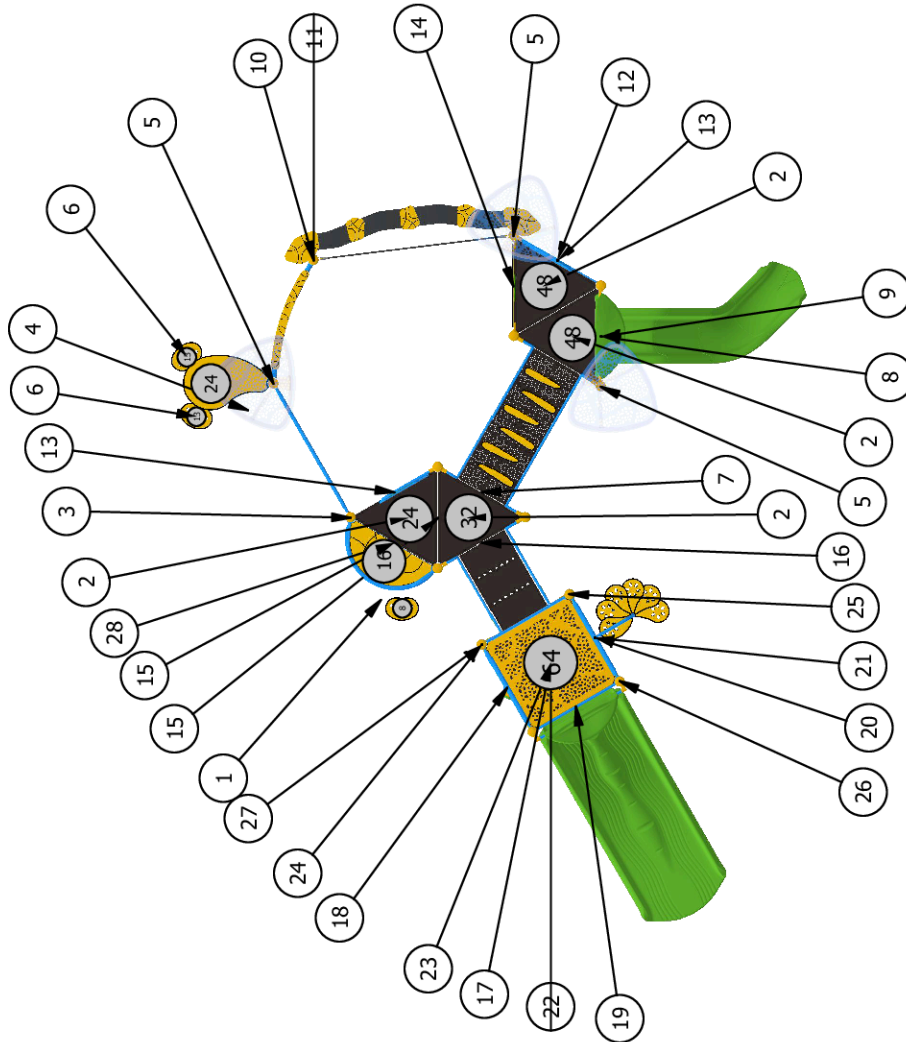

SERIES Burke Basics | Nucleus

GROUP:
NU-3689

DESIGNED FOR AGES:
2 to 5

Ed Scheck Park
Bettendorf, IA 52722

Burke
PLAY THAT MOVES YOU

COMPONENT VIEW

03/26/2025

BCI Burke Company
974-197882-2

Designer: Margaret Dechant

ITEM	COMP.	DESCRIPTION
1	550-0228	EVOLUTION ARCH SWING
2	550-0228	EVOLUTION ARCH SWING
	-END_R	
3	550-0229	EVOLUTION ARCH SWING ADDED BAY
4	550-0228	EVOLUTION ARCH SWING
	-MID	
5	550-0228	EVOLUTION ARCH SWING
	-END_L	
6	550-0111	BELT SEAT, 8' SINGLE, STD CHAIN

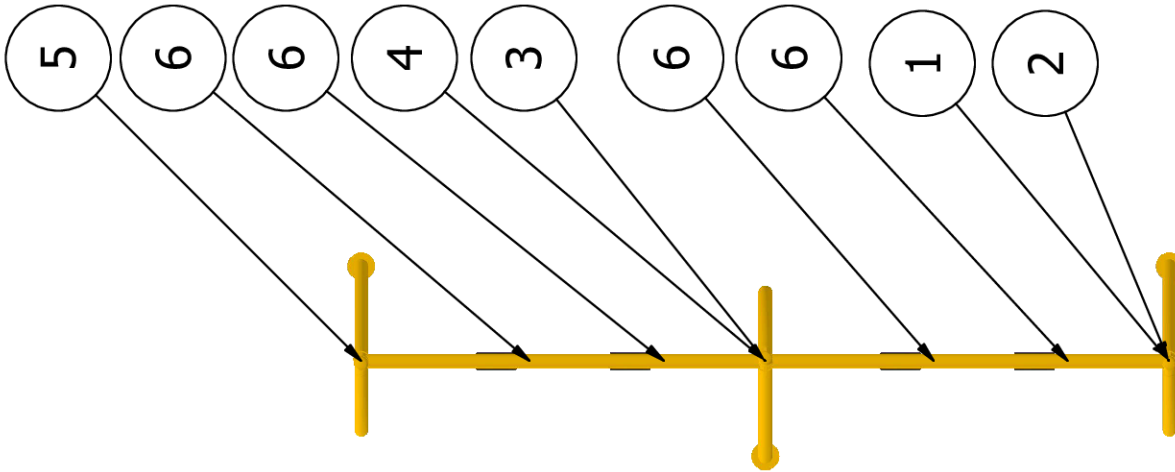

SERIES Burke Basics

COMPONENT VIEW

GROUP:
Freestanding

Ed Scheck Park
Bettendorf, IA 52722

03/26/2025

DESIGNED FOR AGES:
2 to 12

Burke
PLAY THAT MOVES YOU

BCI Burke Company
974-197882-2
Designer: Margaret Dechant

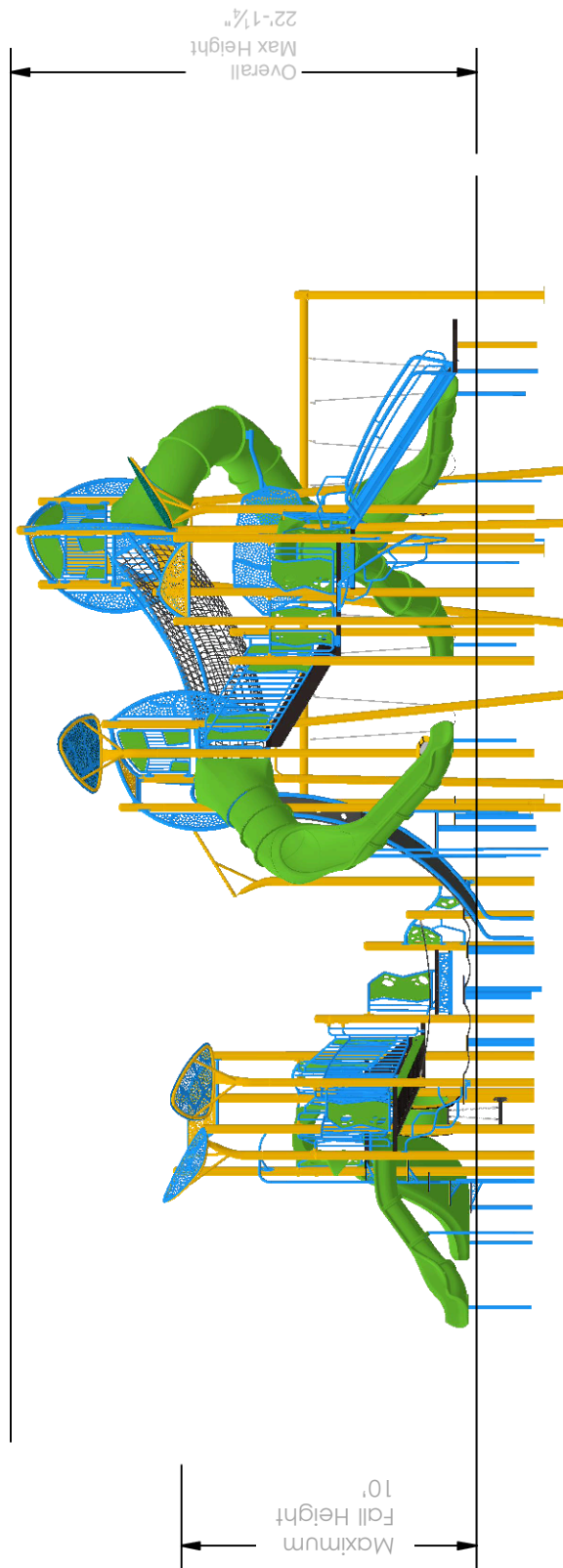

SERIES Nucleus | Burke Basics

GROUP:
 NU-3437|NU-3689|Freestanding

DESIGNED FOR AGES:
 5 to 12, 2 to 5, 2 to 12

Ed Scheck Park
 Bettendorf, IA 52722



ELEVATION VIEW

03/26/2025

BCI Burke Company
 974-197882-2

Designer: Margaret Dechant

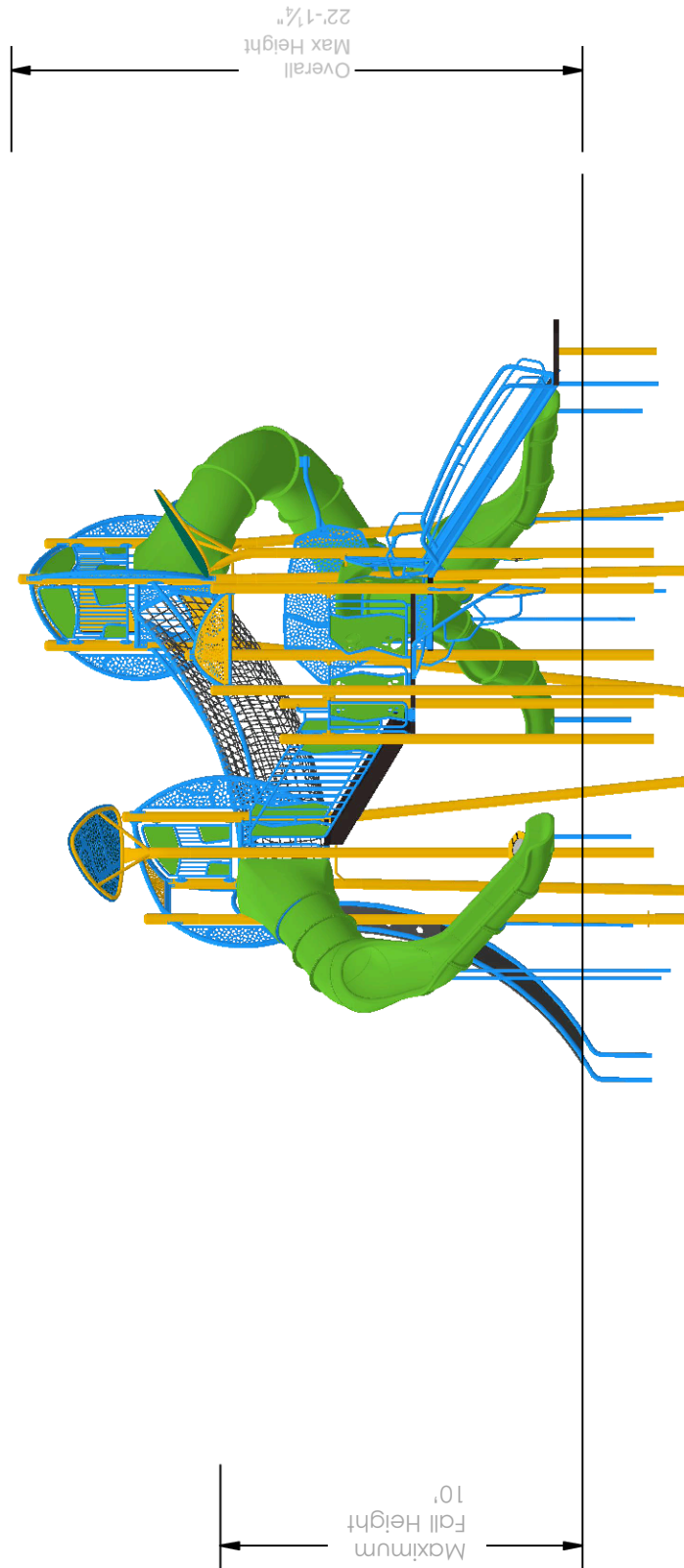

SERIES Nucleus

GROUP:
NU-3437

DESIGNED FOR AGES:
5 to 12

Ed Scheck Park
Bettendorf, IA 52722

Burke
PLAY THAT MOVES YOU

ELEVATION VIEW

03/26/2025

BCI Burke Company
974-197882-2

Designer: Margaret Dechant

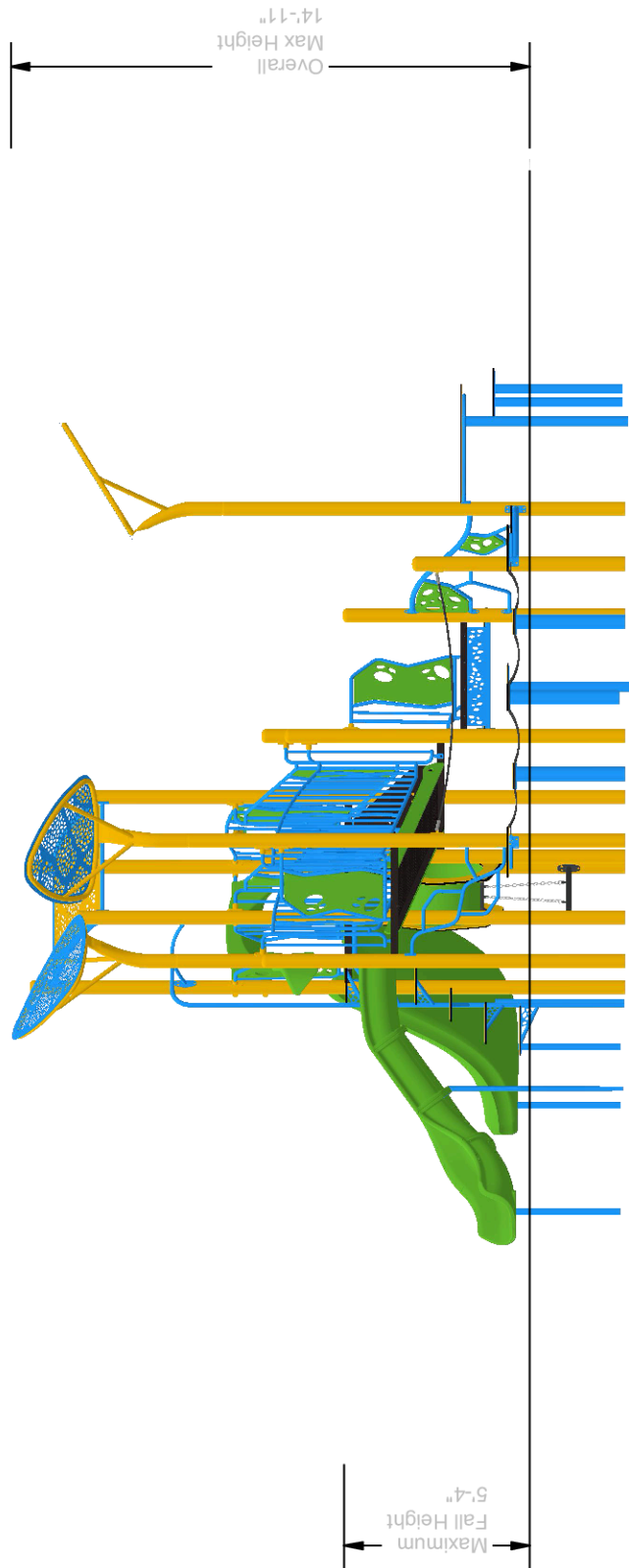

SERIES Burke Basics | Nucleus

GROUP:
NU-3689

DESIGNED FOR AGES:
2 to 5

Ed Scheck Park
Bettendorf, IA 52722

Burke
PLAY THAT MOVES YOU

ELEVATION VIEW

03/26/2025

BCI Burke Company
974-197882-2

Designer: Margaret Dechant

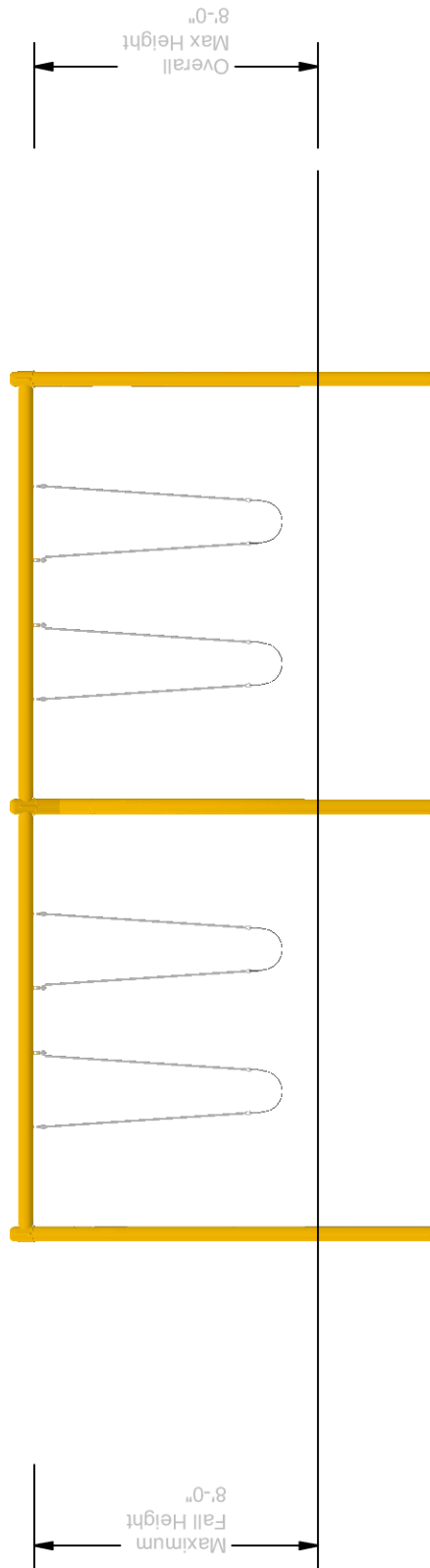

SERIES Burke Basics

ELEVATION VIEW

GROUP:
Freestanding

Ed Scheck Park
Bettendorf, IA 52722

03/26/2025

DESIGNED FOR AGES:
2 to 12

Burke
PLAY THAT MOVES YOU

BCI Burke Company
974-197882-2
Designer: Margaret Dechant

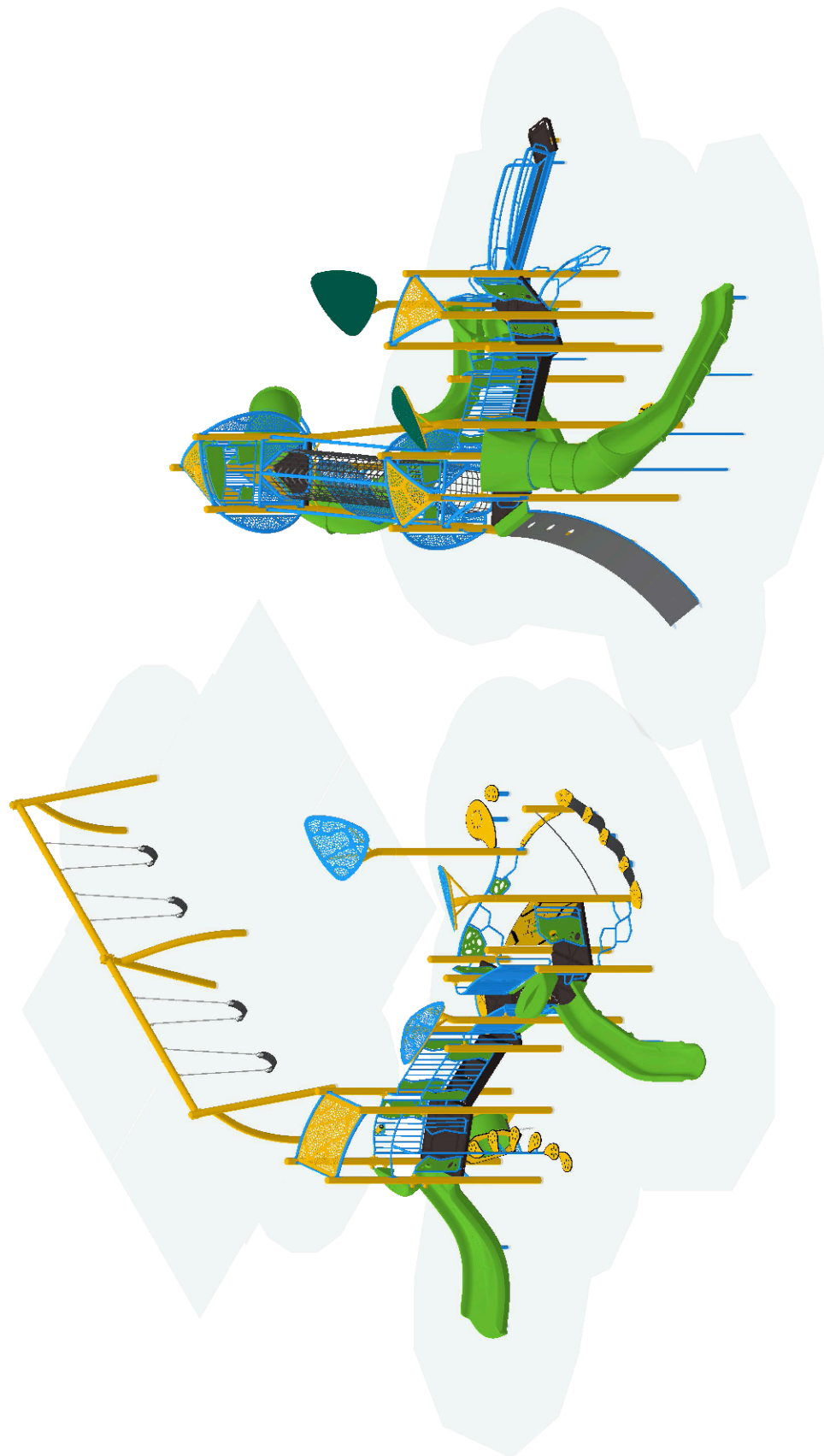

SERIES Nucleus | Burke Basics

GROUP:
NU-3437|NU-3689|Freestanding

DESIGNED FOR AGES:
5 to 12, 2 to 5, 2 to 12

Ed Scheck Park
Bettendorf, IA 52722

Burke
PLAY THAT MOVES YOU

ISOMETRIC VIEW

03/26/2025

BCI Burke Company
974-197882-2

Designer: Margaret Dechant

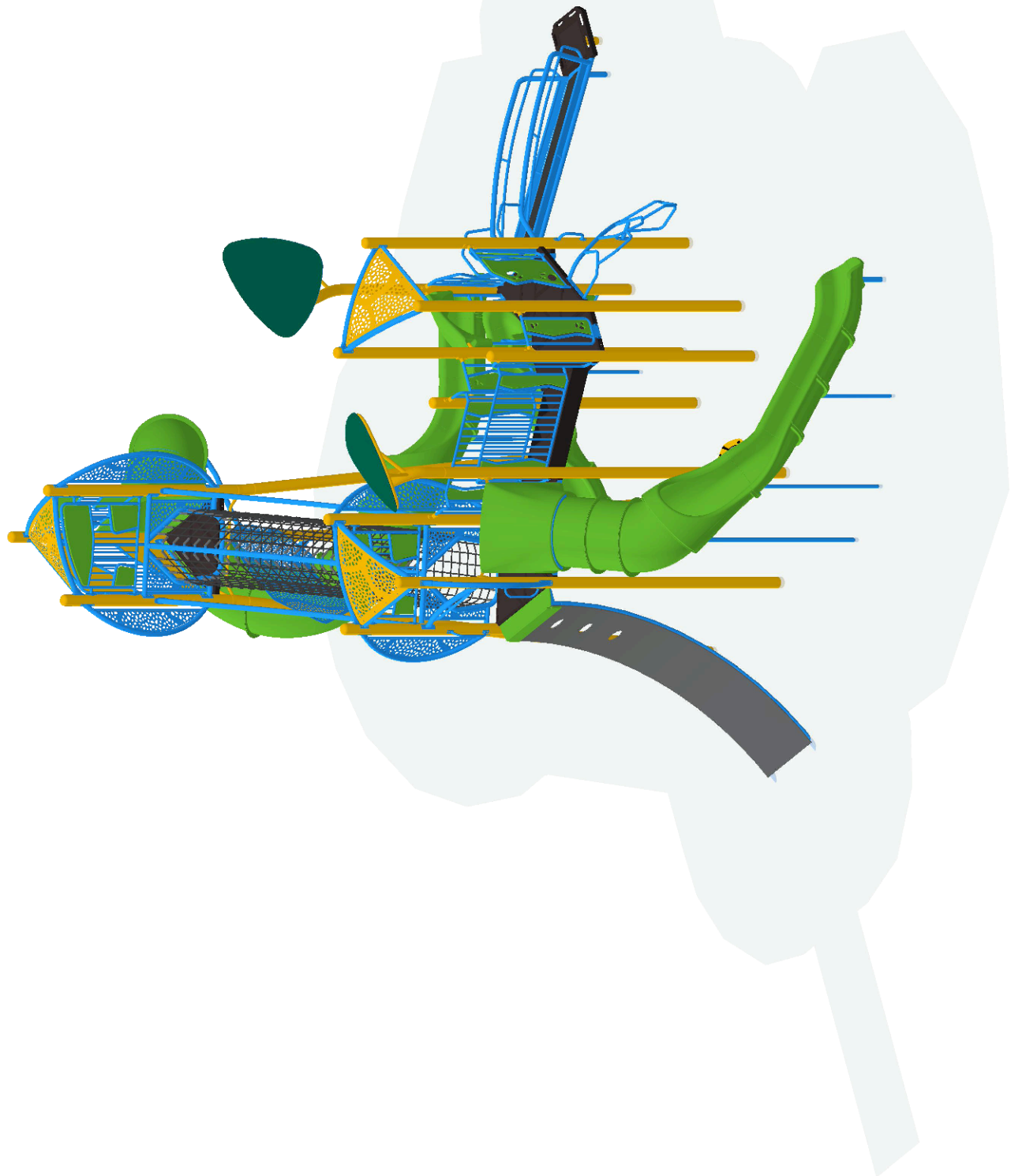

SERIES Nucleus

ISOMETRIC VIEW

GROUP:
NU-3437

Ed Scheck Park
Bettendorf, IA 52722

03/26/2025

DESIGNED FOR AGES:
5 to 12

Burke
PLAY THAT MOVES YOU

BCI Burke Company
974-197882-2

Designer: Margaret Dechant

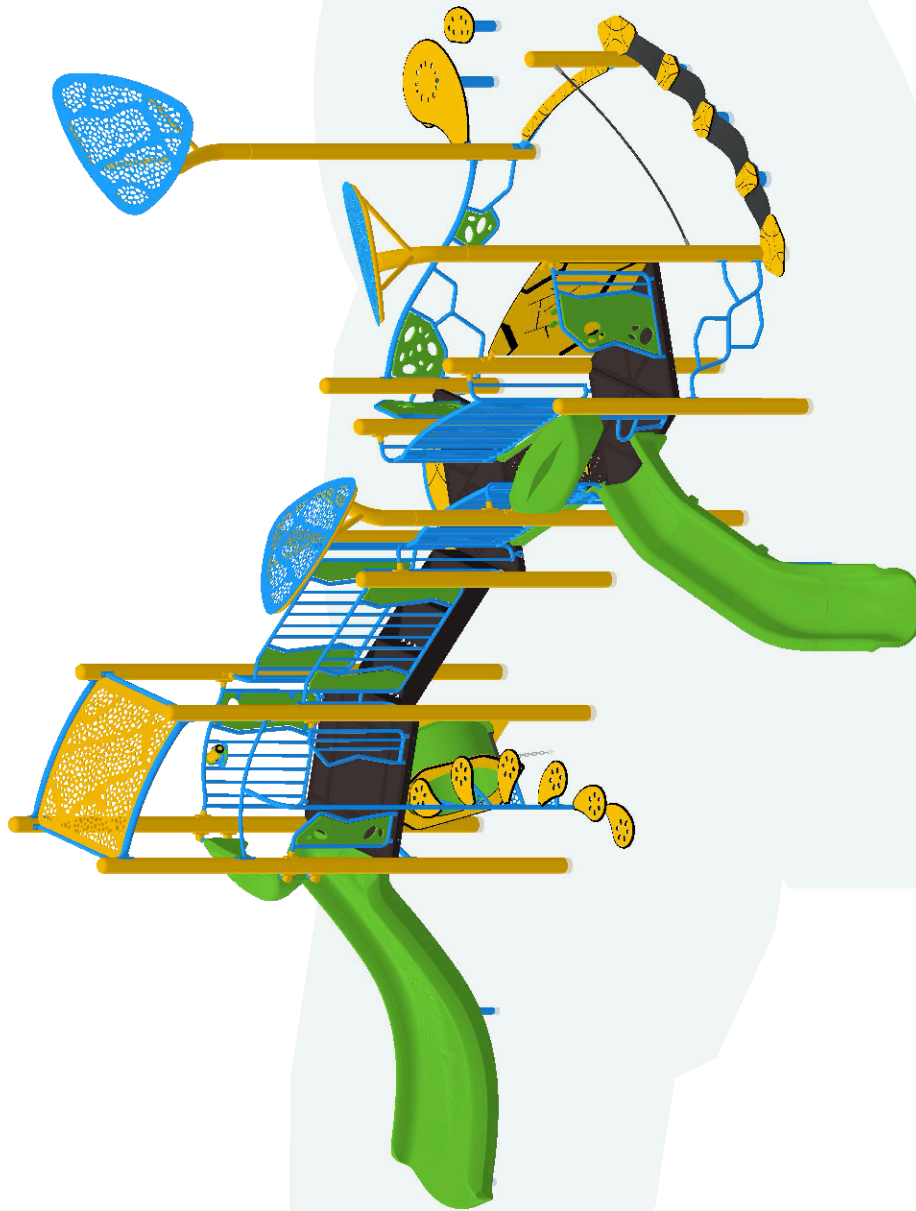

SERIES Burke Basics | Nucleus

GROUP:
NU-3689

DESIGNED FOR AGES:
2 to 5

Ed Scheck Park
Bettendorf, IA 52722

Burke
PLAY THAT MOVES YOU

ISOMETRIC VIEW

03/26/2025

BCI Burke Company
974-197882-2

Designer: Margaret Dechant

BCI BURKE COMPANY, LLC | PO BOX 549 FOND DU LAC, WI 54936-0549 | 920.921.9220 | BCIBURKE.COM

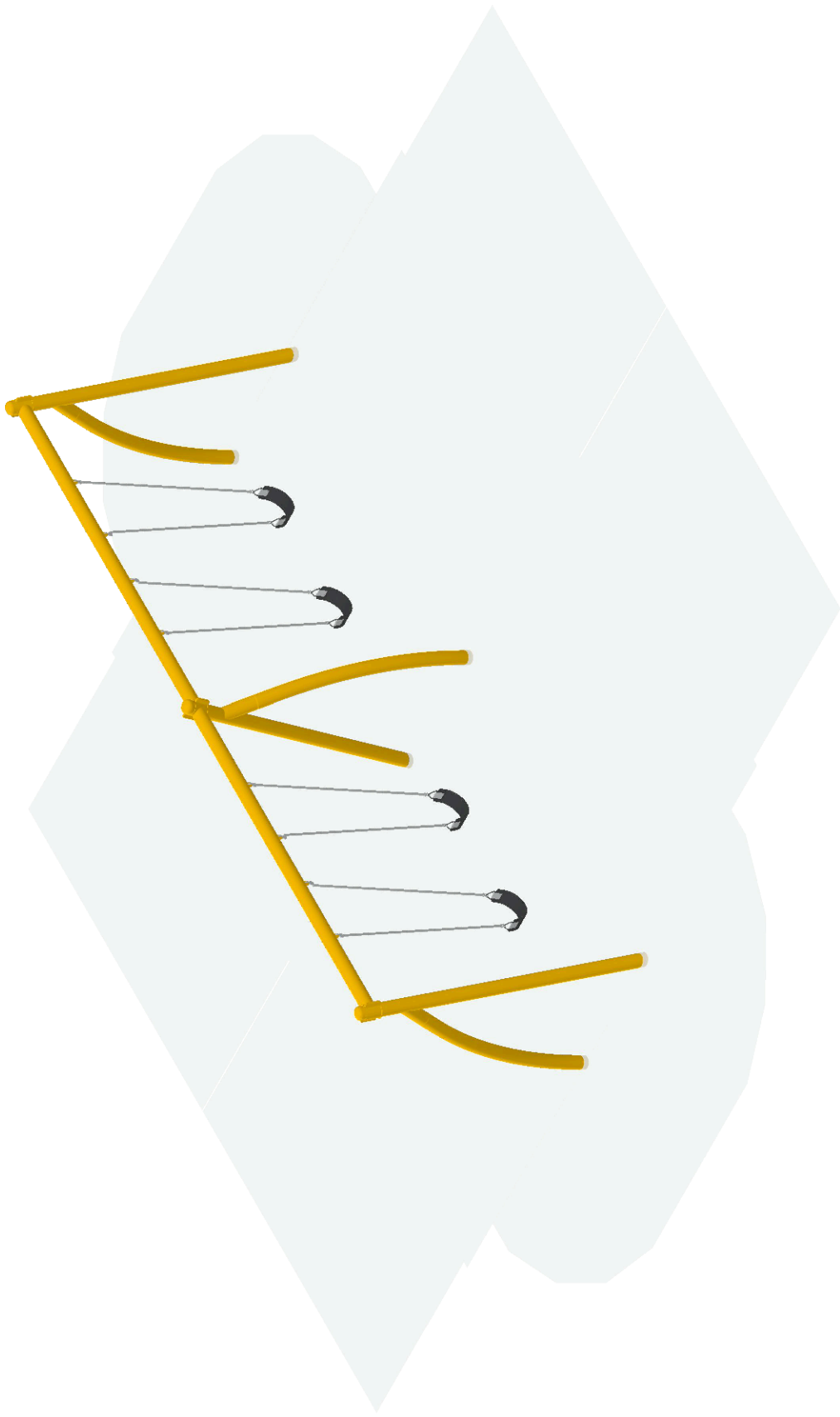

SERIES Burke Basics

GROUP:
Freestanding

DESIGNED FOR AGES:
2 to 12

Ed Scheck Park
Bettendorf, IA 52722

Burke
PLAY THAT MOVES YOU

ISOMETRIC VIEW

03/26/2025

BCI Burke Company
974-197882-2

Designer: Margaret Dechant

Proposal 974-197882-2 | 3/26/2025 | 2025 Pricing

The play components identified in this proposal are IPEMA certified. The use and layout of these components conform to the requirements of ASTM F1487. To verify product certification, visit www.ipema.org.



The space requirements shown in this proposal are to ASTM standards. Requirements for other standards may be different.

NU-3437

Nucleus

Component No.	Description	Qty	User Cap.	Ext. User Cap.	Weight	Ext. Weight
072-0500-172C	5" OD X 172" CAPPED POST	2	0	0	90	180
072-0500-204C	5" OD X 204" CAPPED POST	2	0	0	107	214
072-0500-216C	5" OD X 216" CAPPED POST	1	0	0	113	113
072-0502-160S	5" OD X 160" SWAGED POST	2	0	0	84	168
072-0502-180S	5" OD X 180" SWAGED POST	1	0	0	94	94
072-0502-208S	5" OD X 208" SWAGED POST	3	0	0	109	327
072-0502-216S	5" OD X 216" SWAGED POST	1	0	0	113	113
072-0502-220S	5" OD X 220" SWAGED POST	1	0	0	115	115
072-5503-100T	5" OD X 100" TOP ALUMINUM CAPPED POST	2	0	0	20	40
072-5503-24T	5" OD X 24" TOP ALUMINUM CAPPED POST	1	0	0	6	6
072-5503-88T	5" OD X 88" TOP ALUMINUM CAPPED POST	3	0	0	18	54
270-0009	8" CLOSURE PLATE, ELLIPSE	1	0	0	8	8
270-0120	EVOLUTION UNITARY ENCLOSURE	1	0	0	34	34
270-0122	EVOLUTION OFFSET ENCLOSURE	1	0	0	34	34
270-0129	TRIANGLE PLATFORM	5	2	10	48	240
270-0290	HALF PLATFORM	1	3	3	57	57
370-0041	EVOLUTION 40" TRANSITION STAIR W/ BARRIERS	1	8	8	301	301
370-0068	ASPIRE ROPE TUNNEL	1	7	7	480	480
370-0224	VICTORY CLIMBER	1	1	1	328	328
370-1721	ION CLIMBER 64"-80"	1	2	2	50	50
370-1729	360 LOOP CLIMBER	1	4	4	347	347
470-0006	EVOLUTION BOTTOM ROOF SUPPORT, SINGLE	3	0	0	13	39
470-0008	EVOLUTION SIDE ROOF SUPPORT, LEFT	3	0	0	16	48
470-0009	EVOLUTION SIDE ROOF SUPPORT, RIGHT	3	0	0	16	48
470-0017	EVOLUTION TRIANGLE APEX ROOF	3	0	0	21	63
470-0130	ASPIRE COBRA 168"	1	3	3	529	529

4792 Mayfield Dr | Bettendorf, IA 52722

470-0353	COBRA SLIDE FUSION LEFT 120"	1	3	3	338	338
470-0760	SOLIS HUE POST TOPPER	2	0	0	99	198
470-0805	SLIDE HOOD, HIGH SIDE WALL	1	0	0	32	32
470-0811	EVOLUTION ROOF END PLATE	1	0	0	12	12
470-0850	CSA VIPER S 64-72 W/O HOOD	1	2	2	139	139
570-0001	ASPIRE SMALL WING	4	0	0	33	132
570-0002	ASPIRE MEDIUM WING	2	0	0	43	86
570-0072	EVOLUTION HALF BARRIER	2	0	0	26.6	53.2
570-1544	EVOLUTION SHORT CURVED TOP BARRIER	3	0	0	50	150
570-1545	EVOLUTION 6' OPENING BARRIER	1	0	0	78	78
570-2707	RAIN CRESCENT PANEL	1	1	1	16	16
570-2732	PLAYENSEMBLE BABEL DRUM	1	1	1	14	14
670-0006	ASPIRE TRIPOD CONNECTOR	1	0	0	39	39
670-0007	ASPIRE BIPOD CONNECTOR	1	0	0	20	20
670-0427	5" OD X 11 GA POST EXTENSION	1	0	0	10	10

Total User Capacity: 45
Total Weight: 5359 lbs.
Total Price: \$105,430

Freestanding

Burke Basics

Component No.	Description	Qty	User Cap.	Ext. User Cap.	Weight	Ext. Weight
550-0111	BELT SEAT, 8' SINGLE, STD CHAIN	4	1	4	10	40
550-0228	EVOLUTION ARCH SWING	1	0	0	399	399
550-0229	EVOLUTION ARCH SWING ADDED BAY	1	0	0	240	240

Total User Capacity: 4
Total Weight: 681 lbs.
Total Price: \$5,643

NU-3689

Nucleus

Component No.	Description	Qty	User Cap.	Ext. User Cap.	Weight	Ext. Weight
072-0500-116C	5" OD X 116" CAPPED POST	1	0	0	61	61
072-0500-124C	5" OD X 124" CAPPED POST	3	0	0	65	195
072-0500-132C	5" OD X 132" CAPPED POST	1	0	0	69	69
072-0500-188C	5" OD X 188" CAPPED POST	2	0	0	99	198
072-0500-204C	5" OD X 204" CAPPED POST	2	0	0	107	214
072-0500-72C	5" OD X 72" CAPPED POST	1	0	0	38	38
072-0500-96C	5" OD X 96" CAPPED POST	1	0	0	51	51
072-0502-144S	5" OD X 144" SWAGED POST	1	0	0	76	76
072-0502-156S	5" OD X 156" SWAGED POST	1	0	0	82	82

4792 Mayfield Dr | Bettendorf, IA 52722

072-0502-160S	5" OD X 160" SWAGED POST	1	0	0	84	84
270-0009	8" CLOSURE PLATE, ELLIPSE	2	0	0	8	16
270-0121	EVOLUTION STANCHION	1	0	0	43	43
270-0122	EVOLUTION OFFSET ENCLOSURE	2	0	0	34	68
270-0129	TRIANGLE PLATFORM	4	2	8	48	192
270-0130	SQUARE PLATFORM	1	6	6	106	106
370-0040	EVOLUTION 32" TRANSITION STAIR W/ BARRIERS	1	6	6	239	239
370-0181	PATHWAY LINK, POST TO POST	1	10	10	161	161
370-0203	LINX CLIMBER	1	3	3	112	112
370-0210	TERREX CLIMBER	1	12	12	326	326
370-1664	SHASTA CLIMBER, 40"-48"	1	2	2	20	20
370-1673	PETAL STEP CLIMBER 64"-72"	1	4	4	66	66
370-1739	LIL NOVO BALANCE BEAM POST TOPOST	1	3	3	31	31
470-0003	EVOLUTION TOP ROOF SUPPORT, SINGLE	1	0	0	13	13
470-0006	EVOLUTION BOTTOM ROOF SUPPORT, SINGLE	1	0	0	13	13
470-0008	EVOLUTION SIDE ROOF SUPPORT, LEFT	1	0	0	16	16
470-0009	EVOLUTION SIDE ROOF SUPPORT, RIGHT	1	0	0	16	16
470-0015	EVOLUTION SQUARE ROOF	1	0	0	42	42
470-0075	CRESCENT PLATFORM	1	1	1	52	52
470-0660	VIPER L 48-56 W/O HOOD	1	2	2	126	126
470-0764	SOLIS POST TOPPER	3	0	0	87	261
470-0803	CONTOUR SLIDE, 64"-72"	1	4	4	232	232
470-0805	SLIDE HOOD, HIGH SIDE WALL	1	0	0	32	32
470-0980	NICHE CAPSULE NANO, 64"	1	2	2	108	108
570-0130	EVOLUTION BARRIER W/ KALEIDOSCOPE	1	1	1	64	64
570-2736	PISTON PANEL	1	1	1	47	47

NU-3689

Burke Basics

Component No.	Description	Qty	User Cap.	Ext. User Cap.	Weight	Ext. Weight
580-1355	LIL NOVO BEAN BENCH	2	1	2	28	56
580-1364	LIL NOVO BEAN STEP	1	1	1	28	28
580-1370	NUCLEUS LIL NOVO BEAN TABLE	1	5	5	60	60

Total User Capacity: 73
Total Weight: 3614 lbs.
Total Price: \$51,309

Special Notes:

4792 Mayfield Dr | Bettendorf, IA 52722

Prices do not include freight, unloading, material storage, site excavation/preparation, removal of existing equipment, removal of excess soil from footing holes, site security, safety surfacing, installation, or sales tax (if applicable). Prices are based on standard colors per CURRENT YEAR BCI Burke Catalog. Custom colors, where available, would be an extra charge. **Pricing is valid for 30 days from the date of this proposal.**

Proposal 974-197882-2 | 3/26/2025 | 2025 Pricing

COLOR SELECTION LIST | Default Color Option

GROUP 1 (NU-3437)

Deck: Brown
Post: Yellow
Acc: Sky
Acrylic: Green
Panel: Yellow-Black-Yellow
Flat: Lime
Plastic: Lime

GROUP 2 (NU-3689)

Panel: Yellow-Black-Yellow
Acc: Sky
Deck: Brown
Post: Yellow
Flat: Lime
Plastic: Lime

GROUP 3 (Freestanding)

Post: Yellow

COLORS THAT MOVE YOU

POWDER COAT PAINT



TRADITIONAL SERIES SITE AMENITIES

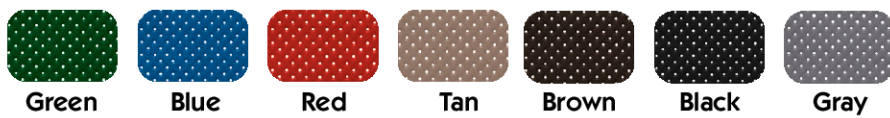

PLATFORMS

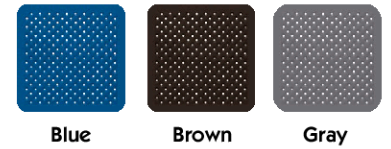

SOLIS HUE TOPPERS



ROCKIT CLIMBERS

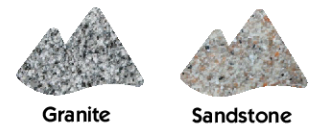

HDPE PLASTIC PANELS



SHADE CANOPIES

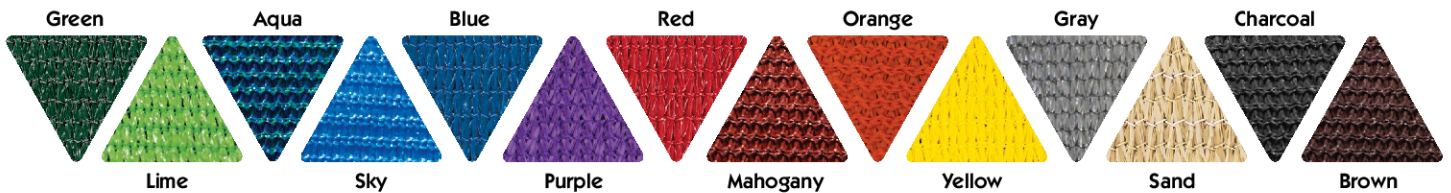

ROTOMOLD PLASTIC

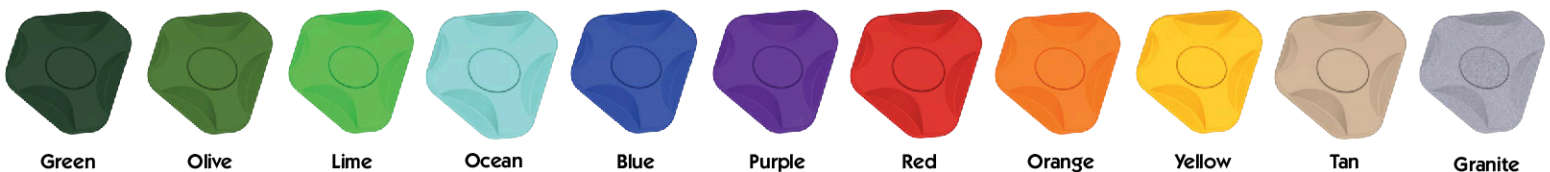

VISIT BCIBURKE.COM/COLOR TO CUSTOMIZE YOUR PLAYGROUND COLORS!

BURKE GENERATIONS WARRANTY®

BCI Burke Company, LLC ("Burke") warrants that all standard products are warranted to be free from defects in materials and workmanship, under normal use and service, for a period of one (1) year from the date of shipment.

We stand behind our products.

In addition, the following products are warranted, under normal use and service from the date of shipment as follows:

- One Hundred (100) Year Limited Warranty on aluminum and steel upright posts (including Nucleus®, Nucleus Evolution®, Nucleus Aspire®, Intensity®, Level X®, Synergy®, Synergy Imagination® & 4ME®) against structural failure due to corrosion, deterioration or workmanship.
- One Hundred (100) Year Limited Warranty on KoreKconnect® Clamp Castings against structural failure due to corrosion, deterioration or workmanship.
- One Hundred (100) Year Limited Warranty on Hardware (nuts, bolts, washers).
- One Hundred (100) Year Limited Warranty on bolt-through and direct-bolt fastening and clamp systems (Synergy®, Intensity®, Nucleus®).
- Twenty-Five (25) Year Limited Warranty on spring assemblies and aluminum cast animals.
- Fifteen (15) Year Limited Warranty on structure platforms and decks, metal roofs, table tops, bench tops, railings and barriers against structural failure due to materials or workmanship.
- Fifteen (15) Year Limited Warranty on all plastic components against structural failure due to materials or workmanship.
- Ten (10) Year Limited Warranty on ShadePlay® Canopies fabric, threads, and cables against degradation, cracking or material breakdown resulting from ultra-violet exposure, natural deterioration or manufacturing defects. This warranty is limited to the design loads as stated in the specifications.
- Ten (10) Year Limited Warranty on NaturePlay® Boulders and GFRC products against structural failure due to natural deterioration or workmanship. Natural wear, which may occur with any concrete product with age, is excluded from this warranty.
- Ten (10) Year Limited Warranty on Full Color Custom Signage against manufacturing defects that cause delamination or degradation of the sign. Full Color Custom Signs also carry a two (2) year warranty against premature fading of the print and graphics on the signs.
- Five (5) Year Limited Warranty on Nucleus®, Intensity®, and RopeVenture® cables against premature wear due to natural deterioration or manufacturing defects. Determination of premature wear will be at the manufacturer's discretion.
- Five (5) Year Limited Warranty on rubber belt material against premature wear due to natural deterioration or manufacturing defects. Determination of premature wear will be at the manufacturer's discretion.
- Five (5) Year Limited Warranty on moving parts, including swing components, against structural failure due to materials or workmanship.
- Five (5) Year Limited Warranty on PlayEnsemble® cables and mallets against defects in materials and workmanship.
- Three (3) Year Limited Warranty on electronic panel speakers, sound chips and circuit boards against electronic failure caused by manufacturing defects.

The warranty stated above is valid only if the equipment is erected in conformity with the layout plan and/or installation instructions furnished by BCI Burke Company, LLC using approved parts; have been maintained and inspected in accordance with BCI Burke Company, LLC instructions. Burke's liability and your exclusive remedy hereunder will be limited to repair or replacement of those parts found in Burke's reasonable judgment to be defective. Any claim made within the above stated warranty periods must be made promptly after discovery of the defect. A part is covered only for the original warranty period of the applicable part. Replacement parts carry the applicable warranty from the date of shipment of the replacement from Burke. After the expiration of the warranty period, you must pay for all parts, transportation and service charges.

Burke reserves the right to accept or reject any claim in whole or in part. Burke will not accept the return of any product without its prior written approval. Burke will assume transportation charges for shipment of the returned product if it is returned in strict compliance with Burke's written instructions.

THE FOREGOING WARRANTIES ARE EXCLUSIVE AND IN LIEU OF ANY OTHER WARRANTY, EXPRESS OR IMPLIED, INCLUDING BUT NOT LIMITED TO ANY IMPLIED WARRANTY OR MERCHANTABILITY OR FITNESS FOR A PARTICULAR PURPOSE. IF THE FOREGOING DISCLAIMER OF ADDITIONAL WARRANTIES IS NOT GIVEN FULL FORCE AND EFFECT, ANY RESULTING ADDITIONAL WARRANTY SHALL BE LIMITED IN DURATION TO THE EXPRESS WARRANTIES AND BE OTHERWISE SUBJECT TO AND LIMITED BY THE TERMS OF BURKE'S PRODUCT WARRANTY. SOME STATES DO NOT ALLOW THE EXCLUSION OF CERTAIN IMPLIED WARRANTIES, SO THE ABOVE LIMITATION MAY NOT APPLY TO YOU.

Warranty Exclusions: The above stated warranties do not cover: "cosmetic" defects, such as scratches, dents, marring, or fading; damage due to incorrect installation, vandalism, misuse, accident, wear and tear from normal use, exposure to extreme weather, immersion in salt or chlorine water, unauthorized repair or modification, abnormal use, lack of maintenance, or other cause not within Burke's control; and

Limitation of Remedies: Burke is not liable for consequential or incidental damages, including but not limited to labor costs or lost profits resulting from the use of or inability to use the products or from the products being incorporated in or becoming a component of any other product. If, after a reasonable number of repeated efforts, Burke is unable to repair or replace a defective or nonconforming product, Burke shall have the option to accept return of the product, or part thereof, if such does not substantially impair its value, and return the purchase price as the buyer's entire and exclusive remedy. Without limiting the generality of the foregoing, Burke will not be responsible for labor costs involved in the removal of products or the installation of replacement products. Some states do not allow the exclusion of incidental damages, so the above exclusion may not apply to you.

The environment near a saltwater coast can be extremely corrosive. Some corrosion and/or deterioration is considered "normal wear" in this environment. Product installed within 500 yards of a saltwater shoreline will only be covered for half the period of the standard product warranty, up to a maximum of five years, for defects caused by corrosion. Products installed in direct contact with saltwater or that are subjected to salt spray are not covered by the standard warranty for any defects caused by corrosion.

Contact your local Burke Representative for warranty information regarding Burke Turf® and Burke Tile products.

Terms of Sale

Pricing: Prices published in this catalog are in USD, are approximate and do not include shipping & handling, surfacing, installation nor applicable taxes. All prices are subject to change without notice. Contact your Burke representative for current pricing. Payments are to be made in USD.

Weights: Weights are approximate and may vary with actual orders.

Installation: All equipment is shipped unassembled. For a list of factory-certified installers in your area, please contact your Burke representative.

Specifications: Product specifications in this catalog were correct at the time of publication. However, product improvements are ongoing at Burke, and we reserve the right to change or discontinue specifications without notice.

Loss or Damage in Transit: A signed bill of lading is our receipt from a carrier that our shipment to you was complete and in good condition upon arrival. Before you sign, please check the Bill of Lading carefully when the shipment arrives to make sure nothing is missing and there are no damages. Once the shipment leaves our plant, we are no longer responsible for any damage, loss or shortage.

For more information regarding the warranty, call Customer Service at 920-921-9220 or 800-356-2070.

01/2025

SOURCEWELL

BCI Burke - Playground equipment

Contract - #010521-BUR Maturity Date: 2/17/2026 Website: bciburke.com/sourcewell

Today's marketplace

Purchasing culture has changed

- Agencies are shopping and buying through cooperative contracts
- Fewer opportunities to respond to bids and RFPs
- Successful companies have cooperative contracts



Value of cooperative purchasing

Supplier		Participating Agency
A single response replaces numerous, time-consuming bids	Save time & money	Competitive RFP process already satisfied <small>Reduces the impact of agency staff budget cuts & protests</small>
Offer your full line of products & services	Full line of contracted solutions	Choose the products & services they need/want
Leverage the relationships you have earned	Trust and relationships	Select the supplier/rep they want
Promote value and quality over price	Low-bid, Low-quality responses	Avoid unpleasant experience of low-bid, low-quality awards
Provide established, discounted, ceiling-based pricing	National volume pricing	Receive national volume, ceiling-based, discounted pricing



Proposal Evaluation
Playground and Water Play Equipment with Related Accessories and Services RFP #010521

	Possible Points	ABC WATER PRODUCTS INC	AquaWorx, Inc.	BCI Burke Company, LLC	Berliner Sellfabrik Play Equipment Corporation	Columbia Cascade Company	CXT Inc	Ecore International	Henderson Recreation Equipment Limited	Industrial Shadeports Inc.	Keystone Ridge Design, Inc.
Conformance to RFP Requirements	50	32	39	42	37	37	35	37	41	35	43
Pricing	400	322	335	329	278	308	344	323	322	334	336
Financial Viability and Marketplace Success	75	49	54	66	54	51	61	60	57	52	62
Ability to Sell and Deliver Service	100	69	81	83	71	65	78	78	78	65	81
Marketing Plan	50	36	42	45	35	37	39	38	37	38	42
Value Added Attributes	75	45	59	65	57	57	63	60	61	62	63
Warranty	50	42	43	44	42	39	38	40	44	43	42
Depth and Breadth of Offered Equipment, Products, or Services	200	156	155	166	147	148	123	141	154	135	144
Total Points	1,000	751	808	838	721	742	781	777	794	764	813
Rank Order		20	10	5	23	22	14.5	16	13		8

COUNCIL LETTER

MEETING DATE: April 15, 2025

REQUESTED BY: Michelle Spencer, Sr. Admin. Assistant



Item Title

Resolution approving annual and/or special event mobile food unit licenses.

Explanation

The Licensing of mobile food units contribute to the mission of a growing, competitive business environment. The applicant for Kona Ice (new owners), Uncle Sam's Kitchen, and Grilled Cheese Bar have submitted the necessary documentation to issue the respective license and/or permits as required by City of Bettendorf's City Code, Title 3, Chapter 13.

If the matter is not budgeted in the current year, explain why funding is requested and the anticipated source:

N/A

List Attachments

- Resolution

**RESOLUTION APPROVING ANNUAL AND/OR SPECIAL
EVENT MOBILE FOOD UNIT LICENSES**

WHEREAS, the City Council of the City of Bettendorf, Iowa has received application for the following mobile food unit requests:

Kona Ice (new owners), Uncle Sam’s Kitchen, and Grilled Cheese Bar (annual licenses)

BE IT RESOLVED by the City Council of the City of Bettendorf, Iowa, that pursuant to Bettendorf City Code, Title 3, Chapter 13, the aforementioned renewals and/or requests is hereby approved.

PASSED, APPROVED AND ADOPTED this 15th day of April, 2025

Robert S. Gallagher, Mayor

ATTEST:

Decker P. Ploehn, City Clerk

COUNCIL LETTER

MEETING DATE: April 15, 2025

REQUESTED BY: Michelle Spencer, Sr. Admin. Assistant



Item Title

Resolution approving alcohol license renewals and requests.

Explanation

The Licensing of businesses contribute to the mission of a growing, competitive business environment. The applicants for CVS Store #8633, Home2 Suites by Hilton Bettendorf Quad Cities, Cambria Hotel Bettendorf Quad Cities, Iron Tee Golf, Purgatory's Pub, Isle of Capri Center, and The Isle Marina Bar have submitted the necessary documentation to issue the respective license and/or permits as required by the State of Iowa.

A criminal history background check has been requested and/or conducted.

The Bettendorf Fire Department has determined that the applicants are in compliance with federal, state, and local requirements.

If the matter is not budgeted in the current year, explain why funding is requested and the anticipated source:

N/A

List Attachments

- Resolution

**RESOLUTION APPROVING ALCOHOL LICENSE RENEWALS
AND REQUESTS**

WHEREAS, the City Council of the City of Bettendorf, Iowa has received application for the following alcohol license renewals and/or requests:

License renewal(s) for CVS Store #8633, Home2 Suites by Hilton Bettendorf Quad Cities, Cambria Hotel Bettendorf Quad Cities, Iron Tee Golf, Purgatory's Pub, and Isle of Capri Center, and a new license for The Isle Marina Bar

BE IT RESOLVED by the City Council of the City of Bettendorf, Iowa, that pursuant to Iowa Code Chapter 123 the applications be approved; and

BE IT FURTHER RESOLVED that the City Clerk is herewith directed to certify to the Iowa Department of Commerce, Alcoholic Beverages Division, the City Council's approval of said applications.

PASSED, APPROVED AND ADOPTED this 15th day of April, 2025

Robert S. Gallagher, Mayor

ATTEST:

Decker P. Ploehn, City Clerk

Bettendorf City Council AP Disbursements - 04.15.25

Vendor Name	Check Date	Check #	Invoice Date	Invoice #	Memo	Amount	Fund	Dept	Account #	Project
WAGEWORKS	3/18/2025	2500542	3/17/2025	INV7619991	flex claims	1,976.96	General Fund	Balance Sheet	1001-0000-20502	
WAGEWORKS	3/25/2025	2500543	3/24/2025	INV7642447	FLEX CLAIMS	3,162.46	General Fund	Balance Sheet	1001-0000-20502	
WAGEWORKS	4/1/2025	2500556	3/31/2025	INV7673782	flex claims	585.44	General Fund	Balance Sheet	1001-0000-20502	
ELISABETH JENSEN	4/2/2025	129451	3/21/2025	3212025	REFUND ON OFFSET PMT ERROR 03.21.2025	93.52	General Fund	Balance Sheet	1001-0000-20504	
TAMIKO EDWARDS	4/2/2025	129460	3/21/2025	3212025	REFUND ON OFFSET PMT ERROR 03.21.2025	144.71	General Fund	Balance Sheet	1001-0000-20504	
JAY HARTLEY	4/9/2025	129503	4/4/2025	4042025	REFUND ON DOUBLE PAYMENT FOR RECORDS REQUEST	5.00	General Fund	Balance Sheet	1001-0000-20504	
PATTI PIET	4/9/2025	129505	4/4/2025	4042025	REFUND ON DOG LICENSE #75 FOR 2025 YEAR	3.00	General Fund	Balance Sheet	1001-0000-20504	
						5,971.09		Balance Sheet Total		
EDMUND C GRABER	4/2/2025	129450	3/27/2025	32725	Consulting services for March 1-31, 2025	1,832.00	General Fund	Mayor & Council	1001-0101-55013	
WATERFRONT DELI & RESTAURANT	4/2/2025	129464	3/31/2025	145786	Informational meeting w/Mayor Bob, JSechser, LBrown,	164.46	General Fund	Mayor & Council	1001-0101-53004	
						1,996.46		Mayor & Council Total		
MERCHANT SERVICES	2/3/2025	2500534	1/31/2025	125A	Bankcard fees 1% sw1,sw2,sw3	11.81	General Fund	Finance	1001-0201-55032	
MERCHANT SERVICES	3/3/2025	2500538	2/28/2025	225A	Bankcard fees 1 % sw1,sw2,sw3	12.44	General Fund	Finance	1001-0201-55032	
CULLIGAN OF DAVENPORT	4/16/2025	129533	3/26/2025	544987	drinking water	14.95	General Fund	Finance	1001-0202-56007	
CULLIGAN OF DAVENPORT	4/16/2025	129533	3/31/2025	545269	water	7.50	General Fund	Finance	1001-0202-56007	
CULLIGAN OF DAVENPORT	4/16/2025	129533	4/2/2025	545630	water	15.05	General Fund	Finance	1001-0202-56007	
ROCHESTER ARMORED CAR CO., INC.	4/16/2025	129583	3/31/2025	172960	01 armored car	368.22	General Fund	Finance	1001-0202-55081	
STATE OF IOWA - AUDITOR	4/2/2025	129459	3/27/2025	ACFR2023	ACFR Filing 2023	850.00	General Fund	Finance	1001-0202-55013	
ADVANCED BUSINESS SYSTEMS, INC	4/9/2025	129500	3/8/2025	INV411388	finance printer	863.00	General Fund	Finance	1001-0230-54006	
ADVANCED BUSINESS SYSTEMS, INC	4/9/2025	129500	3/13/2025	INV412003	finance printer	236.90	General Fund	Finance	1001-0230-54006	
						2,379.87		Finance Total		
ADVANCED BUSINESS SYSTEMS, INC	4/16/2025	129512	3/10/2025	INV411455	PD PRINTER	46.00	General Fund	Police	1001-0315-54006	
ADVANCED BUSINESS SYSTEMS, INC	4/16/2025	129512	3/10/2025	INV411453	PD PRINTER	98.00	General Fund	Police	1001-0315-54006	
ADVANCED BUSINESS SYSTEMS, INC	4/16/2025	129512	3/10/2025	INV411454	PD PRINTER	109.00	General Fund	Police	1001-0315-54006	
URBAN SDK	4/16/2025	129597	3/31/2025	1657	Traffic Speed & Volume Software	4,500.00	General Fund	Police	1001-0316-56004	
						4,753.00		Police Total		
ELECTRICAL ENGINEERING & EQUIP. CO.	4/16/2025	129537	4/1/2025	7551903-00	Station 4 - generator service call	525.00	General Fund	Fire	1001-0415-54001	
RAYNOR DOOR CO., INC. OF THE QC	4/16/2025	129575	4/3/2025	145762	Bay Door Repair/ST1	268.00	General Fund	Fire	1001-0415-54001	
THYMET PEST CONTROL	4/2/2025	129461	3/26/2025	154212	Monthly Service/ST4	58.00	General Fund	Fire	1001-0415-55081	
TRI-STATE AUTOMATIC SPRINKLER CORP	4/16/2025	129594	2/1/2025	46626	Backflow preventer repair	625.00	General Fund	Fire	1001-0415-54001	
						1,476.00		Fire Total		
ADVANCED WILDLIFE CONTROL COMPANY	4/16/2025	129513	3/31/2025	33125	Wildlife Control	355.00	General Fund	Public Works	1001-0525-54001	Maint Ctr Maint FY24/25
	4/16/2025	129519	3/19/2025	143559	rental scissor lift - ceiling repairs	125.00	General Fund	Public Works	1001-0525-54001	Maint Ctr Maint FY24/25
BETTENDORF HEATING & AC	4/16/2025	129522	3/20/2025	346695	A/C Repair DOT Server Room	348.00	General Fund	Public Works	1001-0525-54001	City Hall Maint FY24/25
CRAWFORD COMPANY	4/16/2025	129532	2/1/2025	3969	Power Supply for Book Sorter	402.94	General Fund	Public Works	1001-0525-54001	Library Maint FY24/25
ECONOMY ROOFING	4/16/2025	129536	3/28/2025	11910	roof repair	259.00	General Fund	Public Works	1001-0525-54001	City Hall Maint FY24/25
GRAYBAR	4/16/2025	129541	3/6/2025	9341152757	temporary power equipment needs	532.85	General Fund	Public Works	1001-0525-54001	City Hall Maint FY24/25
KONE INC.	4/16/2025	129553	3/24/2025	1158900171	elevator repair	666.09	General Fund	Public Works	1001-0525-54001	Maint Ctr Maint FY24/25
MID AMERICAN ENERGY	4/2/2025	129455	2/28/2025	24750-88004 February 2025	Community CenterAlcoholics Anonymous 0948077018FEB25	59.74	General Fund	Public Works	1001-0525-54008	Com Ctr Main FY24/25
MID AMERICAN ENERGY	4/2/2025	129455	2/28/2025	24750-88004 February 2025	Community Center - Bldg 0969077019FEB25	1,201.73	General Fund	Public Works	1001-0525-54008	Com Ctr Main FY24/25
MID AMERICAN ENERGY	4/2/2025	129455	2/28/2025	24750-88004 February 2025	CC Pk Garage Pk Maintby PW building 2628077011FEB25	396.94	General Fund	Public Works	1001-0525-54008	Parks Bldg Maint FY24/25
PER MAR SECURITY SERVICES	4/16/2025	129567	2/10/2025	3526210	install and program keyscan electronic board	413.00	General Fund	Public Works	1001-0525-54001	Maint Ctr Maint FY24/25
RAYNOR DOOR CO., INC. OF THE QC	4/16/2025	129575	3/18/2025	145492	W3 door repair	977.50	General Fund	Public Works	1001-0525-54001	Maint Ctr Maint FY24/25
	4/16/2025	129577	3/4/2025	6275043-00	temporary power equipment needs	430.88	General Fund	Public Works	1001-0525-54001	City Hall Maint FY24/25
REPUBLIC COMPANIES	4/16/2025	129577	3/20/2025	6276500-00	electrical maintenance supplies	292.54	General Fund	Public Works	1001-0525-54001	Maint Ctr Maint FY24/25
REPUBLIC COMPANIES	4/16/2025	129577	3/24/2025	6276724-00	LED bulbs, conduit	45.74	General Fund	Public Works	1001-0525-54001	Maint Ctr Maint FY24/25
REPUBLIC COMPANIES	4/16/2025	129577	4/1/2025	6277419-00	Photo Eye controller	31.92	General Fund	Public Works	1001-0525-54001	Maint Ctr Maint FY24/25
THYMET PEST CONTROL	4/16/2025	129592	3/24/2025	154149	pest control	63.00	General Fund	Public Works	1001-0525-55081	Com Ctr Main FY24/25
THYMET PEST CONTROL	4/16/2025	129592	3/25/2025	154202	pest control	60.00	General Fund	Public Works	1001-0525-55081	Library Maint FY24/25
INTERSTATE BATTERY OF THE	4/16/2025	129546	1/16/2025	288270	Auto Scrubber Batteries	240.00	General Fund	Public Works	1001-0526-56007	Commctr Custodial FY24/25
INTERSTATE BATTERY OF THE	4/16/2025	129546	1/26/2025	288269	Auto Scrubber Batteries	240.00	General Fund	Public Works	1001-0526-56007	Maint Ctr Cust FY24/25
MIRROR IMAGE CLEANING	4/16/2025	129564	3/31/2025	1730	additional custodial service	2,015.00	General Fund	Public Works	1001-0526-55081	Library Custodial FY24/25
HD SUPPLY	4/16/2025	129543	3/26/2025	857053573	disinfectant wipes, batteries, tp	413.89	General Fund	Public Works	1001-0526-56007	Library Custodial FY24/25
ALTORFER RENTS	4/16/2025	129515	3/28/2025	D5282201	Rental for Rink	672.00	General Fund	Public Works	1001-0572-55081	

Bettendorf City Council AP Disbursements - 04.15.25

Vendor Name	Check Date	Check #	Invoice Date	Invoice #	Memo	Amount	Fund	Dept	Account #	Project
BETTENDORF N & S LOCK INC.	4/16/2025	129523	3/21/2025	64158	lock hasp	39.80	General Fund	Public Works	1001-0572-55081	
LIGHTING MAINTENANCE INC.	4/16/2025	129555	3/17/2025	16350	lights, repairs	252.75	General Fund	Public Works	1001-0572-55081	
MID AMERICAN ENERGY	4/2/2025	129455	2/28/2025	24750-88004 February 2025	Eagles Landing Shelter 0045153004FEB25	10.00	General Fund	Public Works	1001-0572-54008	
MID AMERICAN ENERGY	4/2/2025	129455	2/28/2025	24750-88004 February 2025	Dog Park Lights 0322079001FEB25	14.31	General Fund	Public Works	1001-0572-54008	
MID AMERICAN ENERGY	4/2/2025	129455	2/28/2025	24750-88004 February 2025	Lincoln Park Splash Pad 0400125000FEB25	12.02	General Fund	Public Works	1001-0572-54008	
MID AMERICAN ENERGY	4/2/2025	129455	2/28/2025	24750-88004 February 2025	CC Park DekHockey 0408058021FEB25	223.47	General Fund	Public Works	1001-0572-54008	
MID AMERICAN ENERGY	4/2/2025	129455	2/28/2025	24750-88004 February 2025	Middle Park Gazebo 0459012030FEB25	10.00	General Fund	Public Works	1001-0572-54008	
MID AMERICAN ENERGY	4/2/2025	129455	2/28/2025	24750-88004 February 2025	6000 Forest Grove Rd 0632145009FEB25	18.21	General Fund	Public Works	1001-0572-54008	
MID AMERICAN ENERGY	4/2/2025	129455	2/28/2025	24750-88004 February 2025	CC Pk Entrance RestroomAlcoa Grant Building	11.30	General Fund	Public Works	1001-0572-54008	
MID AMERICAN ENERGY	4/2/2025	129455	2/28/2025	24750-88004 February 2025	CC Park Lights Field 7 0839154004FEB25	10.00	General Fund	Public Works	1001-0572-54008	
MID AMERICAN ENERGY	4/2/2025	129455	2/28/2025	24750-88004 February 2025	Scheck Park Shelter &Security Lights 0927077017FEB25	16.99	General Fund	Public Works	1001-0572-54008	
MID AMERICAN ENERGY	4/2/2025	129455	2/28/2025	24750-88004 February 2025	VMP Band Shell 1032077013FEB25	17.32	General Fund	Public Works	1001-0572-54008	
MID AMERICAN ENERGY	4/2/2025	129455	2/28/2025	24750-88004 February 2025	Park Lagoon North FountainHouse East Pole 1179077017FEB25	10.00	General Fund	Public Works	1001-0572-54008	
MID AMERICAN ENERGY	4/2/2025	129455	2/28/2025	24750-88004 February 2025	DG Park Garage 1200077016FEB25	384.23	General Fund	Public Works	1001-0572-54008	
MID AMERICAN ENERGY	4/2/2025	129455	2/28/2025	24750-88004 February 2025	DG Park Baseball Field 1221077017FEB25	10.00	General Fund	Public Works	1001-0572-54008	
MID AMERICAN ENERGY	4/2/2025	129455	2/28/2025	24750-88004 February 2025	DG Park Stone House 1242077018FEB25	109.84	General Fund	Public Works	1001-0572-54008	
MID AMERICAN ENERGY	4/2/2025	129455	2/28/2025	24750-88004 February 2025	Leach Park 1263077019FEB25	20.90	General Fund	Public Works	1001-0572-54008	
MID AMERICAN ENERGY	4/2/2025	129455	2/28/2025	24750-88004 February 2025	Edgewood Park 1305077018FEB25	10.00	General Fund	Public Works	1001-0572-54008	
MID AMERICAN ENERGY	4/2/2025	129455	2/28/2025	24750-88004 February 2025	CC Park Lights Field 5 1331090009FEB25	10.00	General Fund	Public Works	1001-0572-54008	
MID AMERICAN ENERGY	4/2/2025	129455	2/28/2025	24750-88004 February 2025	Riverfront Trail Lights 1363053047FEB25	772.73	General Fund	Public Works	1001-0572-54008	
MID AMERICAN ENERGY	4/2/2025	129455	2/28/2025	24750-88004 February 2025	CC Park Lights 4 Plex 1368027009FEB25	24.87	General Fund	Public Works	1001-0572-54008	
MID AMERICAN ENERGY	4/2/2025	129455	2/28/2025	24750-88004 February 2025	Leach Park 1452077013FEB25	14.71	General Fund	Public Works	1001-0572-54008	
MID AMERICAN ENERGY	4/2/2025	129455	2/28/2025	24750-88004 February 2025	Street Lights Parks Dept 1746077019FEB25	1,074.58	General Fund	Public Works	1001-0572-54008	
MID AMERICAN ENERGY	4/2/2025	129455	2/28/2025	24750-88004 February 2025	DG Park Archery Bldg 1767077010FEB25	294.39	General Fund	Public Works	1001-0572-54008	
MID AMERICAN ENERGY	4/2/2025	129455	2/28/2025	24750-88004 February 2025	Park Lagoon WarmingHouse Lights 1788077011FEB25	123.80	General Fund	Public Works	1001-0572-54008	
MID AMERICAN ENERGY	4/2/2025	129455	2/28/2025	24750-88004 February 2025	Meier Park 600 GrantStreet 1872077013FEB25	13.16	General Fund	Public Works	1001-0572-54008	
MID AMERICAN ENERGY	4/2/2025	129455	2/28/2025	24750-88004 February 2025	Bush Scenic Overlook 2031156000FEB25	14.88	General Fund	Public Works	1001-0572-54008	
	4/2/2025	129455	2/28/2025	24750-88004 February 2025	CC Park Lights Field 1 2040077019FEB25	10.24	General Fund	Public Works	1001-0572-54008	
	4/2/2025	129455	2/28/2025	24750-88004 February 2025	CC Park Shelter 3 andRR at Field 5 2061077010FEB25	21.36	General Fund	Public Works	1001-0572-54008	
MID AMERICAN ENERGY	4/2/2025	129455	2/28/2025	24750-88004 February 2025	CC Park Irrigation andSoccer shelter 2082077011FEB25	10.00	General Fund	Public Works	1001-0572-54008	
MID AMERICAN ENERGY	4/2/2025	129455	2/28/2025	24750-88004 February 2025	DG Park Shelter 1 2229077029FEB25	10.00	General Fund	Public Works	1001-0572-54008	
	4/2/2025	129455	2/28/2025	24750-88004 February 2025	CC Park 4Plex ParkingLot 2250077014FEB25	13.48	General Fund	Public Works	1001-0572-54008	
MID AMERICAN ENERGY	4/2/2025	129455	2/28/2025	24750-88004 February 2025	CC Park Garage/PumpHouse 2271077015FEB25	17.08	General Fund	Public Works	1001-0572-54008	
MID AMERICAN ENERGY	4/2/2025	129455	2/28/2025	24750-88004 February 2025	DG Shelter 1 2334077039FEB25	10.00	General Fund	Public Works	1001-0572-54008	
MID AMERICAN ENERGY	4/2/2025	129455	2/28/2025	24750-88004 February 2025	DG Park Shelter 2 2355077023FEB25	-	General Fund	Public Works	1001-0572-54008	
MID AMERICAN ENERGY	4/2/2025	129455	2/28/2025	24750-88004 February 2025	DG Shelter 3 2355077078FEB25	10.00	General Fund	Public Works	1001-0572-54008	
MID AMERICAN ENERGY	4/2/2025	129455	2/28/2025	24750-88004 February 2025	McManus Park 2418077016FEB25	10.00	General Fund	Public Works	1001-0572-54008	
MID AMERICAN ENERGY	4/2/2025	129455	2/28/2025	24750-88004 February 2025	CC Pk Dog Park Lights 2473159007FEB25	42.93	General Fund	Public Works	1001-0572-54008	
MID AMERICAN ENERGY	4/2/2025	129455	2/28/2025	24750-88004 February 2025	McManus Park 2586077012FEB25	10.00	General Fund	Public Works	1001-0572-54008	
MID AMERICAN ENERGY	4/2/2025	129455	2/28/2025	24750-88004 February 2025	Centennial Garden 2843096000FEB25	10.32	General Fund	Public Works	1001-0572-54008	
MID AMERICAN ENERGY	4/2/2025	129455	2/28/2025	24750-88004 February 2025	Park Lagoon South FountainWest Pole 3207166036FEB25	10.00	General Fund	Public Works	1001-0572-54008	
MID AMERICAN ENERGY	4/2/2025	129455	2/28/2025	24750-88004 February 2025	Field Sike Park 3578121009FEB25	10.00	General Fund	Public Works	1001-0572-54008	
MID AMERICAN ENERGY	4/2/2025	129455	2/28/2025	24750-88004 February 2025	Middle Pk PlaygroundShelter Lights 4755166000FEB25	10.00	General Fund	Public Works	1001-0572-54008	
MID AMERICAN ENERGY	4/2/2025	129455	2/28/2025	24750-88004 February 2025	CC Park Dekhockey &Lights Fields 2&3 5076157007FEB25	13.16	General Fund	Public Works	1001-0572-54008	
MID AMERICAN ENERGY	4/2/2025	129455	2/28/2025	24750-88004 February 2025	DG Park Restroom 5112101010FEB25	10.00	General Fund	Public Works	1001-0572-54008	
MID AMERICAN ENERGY	4/2/2025	129455	2/28/2025	24750-88004 February 2025	CC Park ConcessionStand 5718088005FEB25	16.76	General Fund	Public Works	1001-0572-54008	
MID AMERICAN ENERGY	4/2/2025	129455	2/28/2025	24750-88004 February 2025	Optimist Park 6684072018FEB25	24.08	General Fund	Public Works	1001-0572-54008	
MID AMERICAN ENERGY	4/2/2025	129455	2/28/2025	24750-88004 February 2025	Kiwanis Park 7118127018FEB25	-	General Fund	Public Works	1001-0572-54008	
MID AMERICAN ENERGY	4/2/2025	129455	2/28/2025	24750-88004 February 2025	Forest Grove ParkShelter 7653169001FEB25	27.23	General Fund	Public Works	1001-0572-54008	
PPG ARCHITECTURAL FINISHES	4/16/2025	129570	3/26/2025	945220003447	paint for fields	123.86	General Fund	Public Works	1001-0572-56023	
	4/16/2025	129570	4/8/2025	945220003501	Field Paint	325.22	General Fund	Public Works	1001-0572-56025	
S J SMITH CO. INC.	4/16/2025	129586	3/14/2025	6764756	rental, new helmet	371.97	General Fund	Public Works	1001-0572-55081	
VAN WALL EQUIPMENT, INC.	4/16/2025	129599	3/28/2025	6507189	blower nozzle	283.28	General Fund	Public Works	1001-0572-56023	
						15,167.99		Public Works Total		
MERCHANT SERVICES	2/3/2025	2500534	1/31/2025	125A	BANKCARD FEES LIBRARY	72.07	General Fund	Library	1001-0601-55032	
MERCHANT SERVICES	3/3/2025	2500538	2/28/2025	225A	Bankcard fees Library	52.19	General Fund	Library	1001-0601-55032	

Bettendorf City Council AP Disbursements - 04.15.25

Vendor Name	Check Date	Check #	Invoice Date	Invoice #	Memo	Amount	Fund	Dept	Account #	Project
ADVANCED BUSINESS SYSTEMS, INC	4/9/2025	129500	3/7/2025	INV411284	library printer	137.69	General Fund	Library	1001-0614-54006	
ADVANCED BUSINESS SYSTEMS, INC	4/9/2025	129500	3/19/2025	INV412902	Library Printer	145.25	General Fund	Library	1001-0614-54006	
INGRAM LIBRARY SERVICES, LLC	4/16/2025	129545	3/14/2025	63159049	Juvenile	35.03	General Fund	Library	1001-0680-57085	
INGRAM LIBRARY SERVICES, LLC	4/16/2025	129545	3/26/2025	63162164	Juvenile	26.96	General Fund	Library	1001-0680-57085	
						469.19		Library Total		
LIZ SOLIS-WILLIS	4/16/2025	129558	4/1/2025	250401	Mileage for Coralville Conference	25.62	General Fund	Parks & Recreation	1001-0701-53004	
MEREDITH FABRIZIUS	4/16/2025	129561	4/1/2025	250401	Mileage for Coralville Conference	85.40	General Fund	Parks & Recreation	1001-0703-53004	
LINDA JONES	4/16/2025	129556	3/25/2025	250325	12041 Babysitting for Success Class Instruction	500.00	General Fund	Parks & Recreation	1001-0703-55081	Linda Jones Classes
LINDA JONES	4/16/2025	129556	3/25/2025	250325	12047 Junior Chefs Cooking Class Instruction	400.00	General Fund	Parks & Recreation	1001-0703-55081	Linda Jones Classes
LINDA JONES	4/16/2025	129556	3/25/2025	250325	12042 Safely Home Alone Class Instruction	375.00	General Fund	Parks & Recreation	1001-0703-55081	Linda Jones Classes
JOHANNES BUS SERVICE, INC.	4/2/2025	129453	2/28/2025	46486	February Bus Service-Snowstar	350.00	General Fund	Parks & Recreation	1001-0703-55081	Skiing & Snowboarding Lessons
MERCHANT SERVICES	2/3/2025	2500534	1/31/2025	125A	BANK CARD REC ONLINE	37.00	General Fund	Parks & Recreation	1001-0703-55032	
MERCHANT SERVICES	3/3/2025	2500538	2/28/2025	225A	Bankcard fees REC (online)	37.00	General Fund	Parks & Recreation	1001-0703-55032	
QC SCRUB PUB, LLC	4/16/2025	129571	3/20/2025	5230	Laundry Services	22.50	General Fund	Parks & Recreation	1001-0703-56007	Spring Soccer League
SNOWSTAR CORP	4/16/2025	129589	3/11/2025	250311	73 Snowstar Kids Camp - Bettendorf (x \$155 each)	11,315.00	General Fund	Parks & Recreation	1001-0703-55081	Skiing & Snowboarding Lessons
LIZ SOLIS-WILLIS	4/16/2025	129558	4/1/2025	250401	Mileage for Coralville Conference	59.78	General Fund	Parks & Recreation	1001-0703-53004	
ADVANCED BUSINESS SYSTEMS, INC	4/9/2025	129500	3/20/2025	INV413056	Community Center Printer	275.16	General Fund	Parks & Recreation	1001-0705-54006	
VESTIS	4/16/2025	129600	3/17/2025	6150516270	First Aid Service	29.98	General Fund	Parks & Recreation	1001-0705-56010	
VESTIS	4/16/2025	129600	3/24/2025	6150519784	Supplies	29.98	General Fund	Parks & Recreation	1001-0705-56010	
VESTIS	4/16/2025	129600	1/9/2025	6150482781	Laundry Services - mats	11.50	General Fund	Parks & Recreation	1001-0730-55081	
VESTIS	4/16/2025	129600	1/9/2025	6150482781	First Aid Service	17.49	General Fund	Parks & Recreation	1001-0730-56010	
VESTIS	4/16/2025	129600	1/30/2025	6150493251	Laundry Services - mats	11.50	General Fund	Parks & Recreation	1001-0730-55081	
VESTIS	4/16/2025	129600	1/30/2025	6150493251	First Aid Service	17.49	General Fund	Parks & Recreation	1001-0730-56010	
VESTIS	4/16/2025	129600	3/20/2025	6150518476	Laundry Services	50.60	General Fund	Parks & Recreation	1001-0730-55081	
VESTIS	4/16/2025	129600	3/20/2025	6150518476	First Aid Service	17.49	General Fund	Parks & Recreation	1001-0730-56010	
JORSON & CARLSON, INC.	4/16/2025	129550	3/10/2025	744933	Ice Scraper Knives Cleaning & Sharpening	81.98	General Fund	Parks & Recreation	1001-0730-56007	
MID AMERICAN ENERGY	4/2/2025	129455	2/28/2025	24750-88004 February 2025	The Landing Bldg A/Aquatic Park 0719018127FEB25	3,528.44	General Fund	Parks & Recreation	1001-0730-54008	
MID AMERICAN ENERGY	4/2/2025	129455	2/28/2025	24750-88004 February 2025	The Landing Bldg D - Pool Pumhouse 4223031005FEB25	-	General Fund	Parks & Recreation	1001-0730-54008	
MID AMERICAN ENERGY	4/2/2025	129455	2/28/2025	24750-88004 February 2025	4th of July 0207029002FEB25	-	General Fund	Parks & Recreation	1001-0740-54008	4th Of July
MID AMERICAN ENERGY	4/2/2025	129455	2/28/2025	24750-88004 February 2025	4th of July 4385143004FEB25	10.00	General Fund	Parks & Recreation	1001-0740-54008	4th Of July
MID AMERICAN ENERGY	4/2/2025	129455	2/28/2025	24750-88004 February 2025	4th of July 4683007002FEB25	-	General Fund	Parks & Recreation	1001-0740-54008	4th Of July
MID AMERICAN ENERGY	4/2/2025	129455	2/28/2025	24750-88004 February 2025	4th of July 6523111018FEB25	10.17	General Fund	Parks & Recreation	1001-0740-54008	4th Of July
MID AMERICAN ENERGY	4/2/2025	129455	2/28/2025	24750-88004 February 2025	Temp 4th of July 8183122001FEB25	10.00	General Fund	Parks & Recreation	1001-0740-54008	4th Of July
MID AMERICAN ENERGY	4/2/2025	129455	2/28/2025	24750-88004 February 2025	Temp III 4th of July 8803133008FEB25	-	General Fund	Parks & Recreation	1001-0740-54008	4th Of July
						17,309.08		Parks & Recreation Total		
PETTY CASH/CITY ANNEX	4/16/2025	129568	1/29/2025	25-011	mileage reimbursement - Lisa Fuhrman	108.95	General Fund	Community Development	1001-3002-53004	
ADVANCED BUSINESS SYSTEMS, INC	4/9/2025	129500	3/8/2025	INV411390	PW Printer	251.09	General Fund	Community Development	1001-3006-54006	
B & F CONSTRUCTION CODE SERVICES, INC.	4/16/2025	129520	3/28/2025	67892	3RD PARTY REVIEW FEE 3491 FOREST GROVE DR NEW BDLG	585.00	General Fund	Community Development	1001-3006-55072	
B & F CONSTRUCTION CODE SERVICES, INC.	4/16/2025	129520	3/28/2025	67893	3RD PARTY REVIEW 3459 FOREST GROVE DR ALTERATION	585.00	General Fund	Community Development	1001-3006-55072	
B & F CONSTRUCTION CODE SERVICES, INC.	4/16/2025	129520	3/28/2025	67894	3RD PARTY REVIEW FEE 3457 FOREST GROVE DR SHELL BLDG	1,020.00	General Fund	Community Development	1001-3006-55072	
MERCHANT SERVICES	2/3/2025	2500534	1/31/2025	125A	BANKCARD FEES INSPECTIONS	1,062.81	General Fund	Community Development	1001-3006-55032	
MERCHANT SERVICES	3/3/2025	2500538	2/28/2025	225A	Bankcard fees Inspections	1,295.76	General Fund	Community Development	1001-3006-55032	
PETTY CASH/CITY ANNEX	4/16/2025	129568	1/1/2025	25-010	Holiday Cards for Board	8.55	General Fund	Community Development	1001-3006-56006	
						4,917.16		Community Development		
RIVERBEND SIGNWORKS	4/16/2025	129581	3/31/2025	19425	TBK Bank Sports Complex #2 Banner	3,244.50	General Fund	Economic Development	1001-3501-55033	
						3,244.50		Economic Development		
AHLERS & COONEY, P.C.	4/2/2025	129449	2/26/2025	88134	IAW Rate Case - For professional services rendered and costs	3,525.75	General Fund	Legal	1001-4001-55072	
AHLERS & COONEY, P.C.	4/2/2025	129449	3/21/2025	887888	IAW Rate Case - For professional services rendered and costs	754.50	General Fund	Legal	1001-4001-55072	
						4,280.25		Legal Total		
BETTENDORF ROTARY CLUB	4/16/2025	129524	4/1/2025	10012	Quarterly Dues	200.00	General Fund	City Administration	1001-4101-53001	
IMPERIAL	4/2/2025	129452	3/26/2025	288002:529490	Coffee Supplies for City Hall & Police Dept	190.80	General Fund	City Administration	1001-4101-56006	
QUAD CITY TIMES	4/16/2025	129572	3/25/2025	200360	Publish Annual Salaries 2024	365.31	General Fund	City Administration	1001-4101-55014	
RACOM	4/2/2025	129457	3/26/2025	30083	BEON Access 7/1/24-6/30/25 - DPloehn, City Administrator	153.00	General Fund	City Administration	1001-4101-56007	
MERCHANT SERVICES	2/3/2025	2500534	1/31/2025	125A	BANKCARD FEES BUSINESS LIC	54.55	General Fund	City Administration	1001-4102-55032	
MERCHANT SERVICES	3/3/2025	2500538	2/28/2025	225A	Bankcard fees Business Lic	43.00	General Fund	City Administration	1001-4102-55032	
QUAD CITY TIMES	4/16/2025	129572	3/5/2025	199229 & 199230	Publish city council meeting minutes 2/18/25 meeting	1,120.33	General Fund	City Administration	1001-4102-55014	

Bettendorf City Council AP Disbursements - 04.15.25

Vendor Name	Check Date	Check #	Invoice Date	Invoice #	Memo	Amount	Fund	Dept	Account #	Project
	4/16/2025	129572	3/14/2025	200041	Publish notice of public hearing on the proposed tax levy	116.24	General Fund	City Administration	1001-4102-55014	
QUAD CITY TIMES	4/16/2025	129572	3/18/2025	200282	Publish city council meeting minutes 3/4/25 meeting minutes	365.31	General Fund	City Administration	1001-4102-55014	
QUAD CITY TIMES	4/16/2025	129572	3/29/2025	200550	Publish city council meeting minutes 3/18/25 meeting	642.06	General Fund	City Administration	1001-4102-55014	
COLUMN SOFTWARE PBC	4/16/2025	129530	4/1/2025	08037A0C 0092-0106	Publication of multiple public hearing notices and COW meeting	420.77	General Fund	City Administration	1001-4102-55014	
						3,671.37		City Administration Total		
CHAMPS TROPHY	4/16/2025	129529	4/2/2025	3965	1 Retirement brass plate, Kimball, INV 3965	3.25	General Fund	Human Resources	1001-4201-56034	
INGRAM LIBRARY SERVICES, LLC	4/16/2025	129545	2/27/2025	63153463	35 Strength Finders 2.0, INV 63153463	970.90	General Fund	Human Resources	1001-4201-56034	
GENESIS OCCUPATIONAL HEALTH	4/16/2025	129540	3/27/2025	224009	Testing, INV 224009	2,496.00	General Fund	Human Resources	1001-4201-55013	
GENESIS OCCUPATIONAL HEALTH	4/16/2025	129540	4/2/2025	224172	Employee Testing, INV 224172	2,103.00	General Fund	Human Resources	1001-4201-55013	
RANDY RICHARDS	4/16/2025	129574	4/7/2025	4072025	Leadership & Next Level Leadership sessions, development and	2,400.00	General Fund	Human Resources	1001-4202-55072	
						7,973.15		Human Resources Total		
						73,609.11		Grand Total		
						73,609.11	General Fund Total			
	4/9/2025	129500	3/9/2025	INV411431	pw printer	872.67	Road Use Fund	Public Works	2060-0501-54006	
VESTIS	4/16/2025	129600	3/26/2025	6150521256	First Aid Supplies	29.98	Road Use Fund	Public Works	2060-0501-56006	
VESTIS	4/16/2025	129600	4/2/2025	6150524742	First Aid Supplies	29.98	Road Use Fund	Public Works	2060-0501-56006	
CULLIGAN OF DAVENPORT	4/16/2025	129533	3/31/2025	545194	Dispenser rental from 4/1/25 - 4/30/25	9.50	Road Use Fund	Public Works	2060-0501-56006	
PETTY CASH/CITY ANNEX	4/16/2025	129568	1/1/2025	25-008	Mailing Engineering Plans	13.84	Road Use Fund	Public Works	2060-0501-56008	
PETTY CASH/CITY ANNEX	4/16/2025	129568	3/3/2025	25-019	Greater IA Asphalt per diem - Chapman	90.00	Road Use Fund	Public Works	2060-0501-53004	
PETTY CASH/CITY ANNEX	4/16/2025	129568	3/3/2025	25-017	Greater IA Asphalt Per Diem - Verhelst	90.00	Road Use Fund	Public Works	2060-0501-53004	
PETTY CASH/CITY ANNEX	4/16/2025	129568	3/3/2025	25-018	Greater IA Asphalt per diem - Rodriguez	90.00	Road Use Fund	Public Works	2060-0501-53004	
PETTY CASH/CITY ANNEX	4/16/2025	129568	3/7/2025	25-020	Gas for Greater IA Asphalt	10.00	Road Use Fund	Public Works	2060-0501-53004	
PETTY CASH/CITY ANNEX	4/16/2025	129568	3/26/2025	25-023	Travel Reimb for Accessible Sidewalks & Curb Ramps - Fries	47.89	Road Use Fund	Public Works	2060-0501-53004	
SCOTT COUNTY EMERGENCY MANAGEMENT	4/16/2025	129587	3/31/2025	2025-00000007	43 RADIO ACCESS FEES 3RD QTR FY25	3,225.00	Road Use Fund	Public Works	2060-0501-55021	
SCOTT COUNTY EMERGENCY MANAGEMENT	4/16/2025	129587	3/31/2025	2025-00000001	P25 RADIO ACCESS FEES 43 RADIOS CLY25	12,900.00	Road Use Fund	Public Works	2060-0501-55021	
PETTY CASH/CITY ANNEX	4/16/2025	129568	1/1/2025	25-009	CDL Reimb. for Brandon Stanton	32.00	Road Use Fund	Public Works	2060-0511-56007	
RIVERSTONE GROUP INC.	4/16/2025	129582	3/25/2025	1368140	upm mix	687.00	Road Use Fund	Public Works	2060-0511-56007	
RIVERSTONE GROUP INC.	4/16/2025	129582	3/31/2025	1370894	UPM Cold Mix	571.50	Road Use Fund	Public Works	2060-0511-56007	
IOWA PRISON INDUSTRIES	4/16/2025	129547	3/27/2025	301420	posts and bicycle trail stop signs	2,627.50	Road Use Fund	Public Works	2060-0514-56017	
MID AMERICAN ENERGY	4/2/2025	129455	3/14/2025	564471400	6988 MIDDLE RD	18.46	Road Use Fund	Public Works	2060-0530-54008	
MID AMERICAN ENERGY	4/2/2025	129455	3/14/2025	564474485	5304 MIDDLE RD	25.93	Road Use Fund	Public Works	2060-0530-54008	
MID AMERICAN ENERGY	4/2/2025	129455	3/19/2025	56430851	4403 devils glen rd	55.91	Road Use Fund	Public Works	2060-0530-54008	
MID AMERICAN ENERGY	4/2/2025	129455	3/19/2025	564620756	3531 FOREST GROVE DR	64.38	Road Use Fund	Public Works	2060-0530-54008	
STIVERS FORD	4/16/2025	129590	4/2/2025	F52694	new Ford F350 chassis	59,375.50	Road Use Fund	Public Works	2060-0580-57074	
SITEONE LANDSCAPE SUPPLY, LLC	4/16/2025	129588	4/8/2025	151772889	Trees Are Us Funds	3,888.48	Road Use Fund	Parks & Recreation	2060-0709-55081	
URBAN SDK	4/16/2025	129597	3/31/2025	1657	Traffic Speed & Volume Software	6,000.00	Road Use Fund	Capital Projects	2060-5050-55081	SPEED HUMP PROGRAM
BIG TOP MANUFACTURING LLC	4/16/2025	129525	4/3/2025	S0009734-0	Salt Storage Hoop Building Replacement at Maintenance Center -	76,650.00	Road Use Fund	Capital Projects	2060-5050-55081	Pw Hoop Bldg Salt Dome Re
						167,405.52	Road Use Fund Total			
	4/16/2025	129600	3/26/2025	6150521249	First Aid Cabinets	74.95	Library Gift Fund	Library	2260-0606-56006	
						74.95	Library Gift Fund Total			
AVENUE RENTAL, INC.	4/16/2025	129519	3/18/2025	143542	Equipment rental for compacting	65.00	Capital Projects	Capital Projects	4000-5050-55015	Riverfront Bollards
AVENUE RENTAL, INC.	4/16/2025	129519	3/21/2025	143577	Equipment rental for concrete	130.00	Capital Projects	Capital Projects	4000-5050-55015	Riverfront Bollards
DAVENPORT ELECTRIC CONTRACT	4/16/2025	129534	3/27/2025	57056	Excavate for gas and electric repair	4,512.00	Capital Projects	Capital Projects	4000-5050-55081	Riverfront Bollards
GENERAL CONSTRUCTORS, INC.	4/16/2025	129539	3/31/2025	230257 23	CO #1 - Frozen Landing	132,024.75	Capital Projects	Capital Projects	4000-5050-55081	Frozen Landing Replacmnt
PLEASANT VALLEY REDI-MIX INC.	4/16/2025	129569	3/21/2025	70645	Concrete for sidewalk	1,150.00	Capital Projects	Capital Projects	4000-5050-56007	Riverfront Bollards
REPUBLIC COMPANIES	4/16/2025	129577	3/20/2025	6276490-00	Conduit for bridge	89.54	Capital Projects	Capital Projects	4000-5050-56007	Update Traffic Signals
REPUBLIC COMPANIES	4/16/2025	129577	3/21/2025	6276673-00	Wire & Conduit	138.59	Capital Projects	Capital Projects	4000-5050-56007	Update Traffic Signals
RIVERSTONE GROUP INC.	4/16/2025	129582	3/25/2025	1368141	Gravel	91.75	Capital Projects	Capital Projects	4000-5050-56007	Riverfront Bollards
UNITED RENTALS (NORTH AMERICA) INC.	4/16/2025	129596	3/12/2025	233546123-012	storage container rental fee - Agape Center	150.00	Capital Projects	Capital Projects	4000-5050-57074	
UTILITY EQUIPMENT CO.	4/16/2025	129598	3/21/2025	10112556-000	Conduit Repair Clamp	235.23	Capital Projects	Capital Projects	4000-5050-56007	Update Traffic Signals
VALLEY CONSTRUCTION	4/2/2025	129463	2/17/2025	239926	Utility Protection	13,823.00	Capital Projects	Capital Projects	4000-5050-55081	Frst Grv - Intl To Middl
WORKSPACE	4/16/2025	129603	3/25/2025	161420	Office furniture for Transit Manager & Fleet Manager. Omnia	9,773.55	Capital Projects	Capital Projects	4000-5050-57074	Maint Ctr - Locker Rooms
BOLTON AND MENK	4/16/2025	129526	3/19/2025	358759	Central Ave Rehab from 14th to Pius Lane	11,341.50	Capital Projects	Capital Projects	4000-5050-55072	CENTRAL AVE RESURFACE
URBAN SDK	4/16/2025	129597	3/31/2025	1657	Traffic Speed & Volume Software	10,000.00	Capital Projects	Capital Projects	4000-5050-55081	Traffic Signal Studies
						183,524.91	Capital Projects Total			
VAN WALL EQUIPMENT, INC.	4/16/2025	129599	4/8/2025	10934348	Parks - John Deere 1200A Bunker/Field rake	19,226.90	Vehicle Replacement Fund	Finance	4010-0242-57074	

Bettendorf City Council AP Disbursements - 04.15.25

Vendor Name	Check Date	Check #	Invoice Date	Invoice #	Memo	Amount	Fund	Dept	Account #	Project
						19,226.90	Vehicle Replacement Fund Total			
89404 REBECCA SHARPE	4/16/2025	129576	4/8/2025	200789404	REFUND ON DOUBLE PAYMENT ON FINAL BILLED UTILITY ACCT	60.67	Sewer Utility	Balance Sheet	5200-0000-11012	
IOWA DEPARTMENT OF REVENUE	2/28/2025	2500537	1/31/2025	0-007-731-601	Monthly Return Jan	6,582.41	Sewer Utility	Balance Sheet	5200-0000-20401	
AUTHORIZE.NET	3/4/2025	2500539	2/28/2025	225	ONLINE PYMT GATEWAY	30.00	Sewer Utility	Finance	5200-0204-55032	
MERCHANT SERVICES	2/3/2025	2500534	1/31/2025	125A	Bankcard fees ut,sw1 ,sw2	3,518.91	Sewer Utility	Finance	5200-0204-55032	
MERCHANT SERVICES	3/3/2025	2500538	2/28/2025	225A	Bankcard fees ut,sw1 ,sw2	8,032.87	Sewer Utility	Finance	5200-0204-55032	
MIDWEST MAILWORKS INC.	4/16/2025	129562	3/28/2025	254385	03 LATE NOTICES	94.70	Sewer Utility	Finance	5200-0204-55081	
TYLER TECHNOLOGIES	4/16/2025	129595	3/31/2025	025-503406	INSITE TRANSACTIONS 01/01/25-03/31/2025	2,606.00	Sewer Utility	Finance	5200-0204-55023	
PETTY CASH/CITY ANNEX	4/16/2025	129568	1/31/2025	25-012	Meals for APPIA Local Public Agencies - Verhelst	25.00	Sewer Utility	Public Works	5200-0552-53004	
PETTY CASH/CITY ANNEX	4/16/2025	129568	1/31/2025	25-013	Meals for APPIA Local Public Agencies - Nick Young	25.00	Sewer Utility	Public Works	5200-0552-53004	
PETTY CASH/CITY ANNEX	4/16/2025	129568	1/31/2025	25-014	Meals for APPIA Local Public Agencies - Larry Gregorich	25.00	Sewer Utility	Public Works	5200-0552-53004	
JIM SCHROEDER CONSTRUCTION INC.	4/16/2025	129548	3/25/2025	P2500163 4	Spencer Creek Lift Station Bid Package No.1 from 2/27/25 to	549,100.00	Sewer Utility	Capital Projects	5200-5059-55081	Spencer Creek Lift Statn
MCCLURE ENGINEERING CO	4/16/2025	129560	3/31/2025	158648	Amendment #1	48,198.25	Sewer Utility	Capital Projects	5200-5059-55072	Spencer Creek Lift Statn
C2 CREATIVE CONCRETE	4/16/2025	129528	4/4/2025	P2500215 3	PE#3 Palmer Hills Golf Course Entrance Culvert Replacement	5,796.86	Sewer Utility	Capital Projects	5200-5059-55081	PHGC ENTRANCE CULVERT
						624,095.67	Sewer Utility Total			
IOWA DEPARTMENT OF REVENUE	2/28/2025	2500537	1/31/2025	0-007-731-601	Monthly Return Jan	44.94	Solid Waste/Recycling Ent	Balance Sheet	5500-0000-20401	
MERCHANT SERVICES	2/3/2025	2500534	1/31/2025	125A	Bankcard fees recycle,	3,541.23	Solid Waste/Recycling Ent	Finance	5500-0216-55032	
MERCHANT SERVICES	3/3/2025	2500538	2/28/2025	225A	Bankcard fees recycle,	8,055.49	Solid Waste/Recycling Ent	Finance	5500-0216-55032	
MIDWEST MAILWORKS INC.	4/16/2025	129562	3/28/2025	254385	03 LATE NOTICES	94.68	Solid Waste/Recycling Ent	Finance	5500-0216-55081	
	4/16/2025	129595	3/31/2025	025-503406		2,606.00	Solid Waste/Recycling Ent	Finance	5500-0216-55023	
REHRIG PACIFIC COMPANY	4/2/2025	129458	3/31/2025	50468064	(702) 95-gallon recycling carts	43,742.16	Solid Waste/Recycling Ent	Public Works	5500-0509-56004	
WASTE COMMISSION OF SCOTT CO.	4/16/2025	129601	3/31/2025	033125SW1	Solid Waste - March 2025	25,345.15	Solid Waste/Recycling Ent	Public Works	5500-0509-55013	
	4/16/2025	129601	3/31/2025	033125BW	Bulky Waste - March 2025	1,972.22	Solid Waste/Recycling Ent	Public Works	5500-0528-55013	
WASTE COMMISSION OF SCOTT CO.	4/16/2025	129601	3/31/2025	033125EW	E-Waste March 2025	3,795.00	Solid Waste/Recycling Ent	Public Works	5500-0528-55013	
						89,196.87	Solid Waste/Recycling Ent Total			
ADEL WHOLESALERS, INC.	4/16/2025	129511	3/27/2025	2152536	flush valve, handles	132.90	Family Museum	Public Works	5550-0523-54001	Fam Museum Maint FY24/25
WOLKING WINDOW TINTING	4/16/2025	129602	3/21/2025	3621	window tinting - 9 windows	2,058.00	Family Museum	Public Works	5550-0523-54001	Fam Museum Maint FY24/25
MIRROR IMAGE CLEANING	4/16/2025	129564	3/31/2025	1729	additional custodial service	1,716.00	Family Museum	Public Works	5550-0524-55081	FMAS Custodial FY24/25
ADVANCED BUSINESS SYSTEMS, INC	4/9/2025	129500	3/8/2025	INV411389	museum printer	848.85	Family Museum	Family Museum	5550-1101-54006	
VESTIS	4/16/2025	129600	3/26/2025	6150521248	Museum - First Aid Supplies	59.96	Family Museum	Family Museum	5550-1101-56007	
VESTIS	4/16/2025	129600	4/2/2025	6150524733	Museum - First Aid Supplies	59.96	Family Museum	Family Museum	5550-1101-56007	
QUADIENT LEASING USA	4/16/2025	129573	4/2/2025	Q1803253	Museum - Postage Meter Leasing	200.28	Family Museum	Family Museum	5550-1101-56007	
WORLDPAY	3/5/2025	2500540	2/28/2025	225	bankcard fees museum	2,039.92	Family Museum	Family Museum	5550-1101-55032	
ANN PETERS	4/16/2025	129517	4/8/2025	40825	Museum - Art Academy Assistant April 2025	1,275.00	Family Museum	Family Museum	5550-1102-55072	
ALLISON LINDSEY CREATIVE	4/16/2025	129514	4/8/2025	40825	Museum - Art Academy Assistant April 2025	1,232.50	Family Museum	Family Museum	5550-1102-55072	
CONTINENTAL FIRE SPRINKLER CO	4/16/2025	129531	3/24/2025	124312 #3	Museum - Fire Suppression System Payment #3	2,382.50	Family Museum	Family Museum	5550-1105-56046	
						12,005.87	Family Museum Total			
JON WADDELL GOLF SHOP LLC	4/16/2025	129549	2/28/2025	250228	Proshop Payables	1,767.02	Palmer Hills Golf Course	Balance Sheet	5600-0000-20024	
JON WADDELL GOLF SHOP LLC	4/16/2025	129549	2/28/2025	250228	Proshop Tax	138.22	Palmer Hills Golf Course	Balance Sheet	5600-0000-20024	
JON WADDELL GOLF SHOP LLC	4/16/2025	129549	2/28/2025	250228	City's 3%	(60.80)	Palmer Hills Golf Course	Balance Sheet	5600-0000-20024	
JON WADDELL GOLF SHOP LLC	4/16/2025	129549	2/28/2025	250228	Club Repair	215.50	Palmer Hills Golf Course	Balance Sheet	5600-0000-20007	
JON WADDELL GOLF SHOP LLC	4/16/2025	129549	2/28/2025	250228	Lessons	6,675.00	Palmer Hills Golf Course	Balance Sheet	5600-0000-20020	
JON WADDELL GOLF SHOP LLC	4/16/2025	129549	2/28/2025	250228	Tax Exempt Sales	259.48	Palmer Hills Golf Course	Balance Sheet	5600-0000-20025	
KLINE SEWER & DRAIN	4/16/2025	129552	3/22/2025	20701	clean sewer drain	325.00	Palmer Hills Golf Course	Public Works	5600-0523-54001	PHGC Maint FY24/25
MID AMERICAN ENERGY	4/2/2025	129455	2/28/2025	24750-88004 February 2025	PHGC Sign 0549137076FEB25	75.68	Palmer Hills Golf Course	Public Works	5600-0523-54008	PHGC Maint FY24/25
MID AMERICAN ENERGY	4/2/2025	129455	2/28/2025	24750-88004 February 2025	PHGC Maintenance Bldg 1116077014FEB25	380.90	Palmer Hills Golf Course	Public Works	5600-0523-54008	PHGC Maint FY24/25
MID AMERICAN ENERGY	4/2/2025	129455	2/28/2025	24750-88004 February 2025	PHGC Pump House 1137077015FEB25	62.84	Palmer Hills Golf Course	Public Works	5600-0523-54008	PHGC Maint FY24/25
MID AMERICAN ENERGY	4/2/2025	129455	2/28/2025	24750-88004 February 2025	PHGC Clubhouse 4278125007FEB25	1,003.28	Palmer Hills Golf Course	Public Works	5600-0523-54008	PHGC Maint FY24/25
PER MAR SECURITY SERVICES	4/16/2025	129567	3/11/2025	3549682	Inspection Services	325.44	Palmer Hills Golf Course	Public Works	5600-0523-55081	
RAYNOR DOOR CO., INC. OF THE QC	4/16/2025	129575	3/27/2025	145659	Garage Door Opener Repair	170.00	Palmer Hills Golf Course	Public Works	5600-0523-54001	PHGC Maint FY24/25
MIRROR IMAGE CLEANING	4/16/2025	129564	3/31/2025	1742	custodial service	1,630.00	Palmer Hills Golf Course	Public Works	5600-0524-55081	PHGC Custodial FY24/25
VESTIS	4/16/2025	129600	3/21/2025	6150519143	First Aid Service	25.00	Palmer Hills Golf Course	Parks & Recreation	5600-0711-56010	
HORNUNGS PRO GOLF SALES, INC.	4/16/2025	129544	3/10/2025	709073	Logo Bags & Cart Key Tags	206.95	Palmer Hills Golf Course	Parks & Recreation	5600-0711-56007	
MERCHANT SERVICES	2/3/2025	2500534	1/31/2025	125A	BANKCARD FEES GOLF RANGE BALLS	45.00	Palmer Hills Golf Course	Parks & Recreation	5600-0711-55032	
MERCHANT SERVICES	3/3/2025	2500538	2/28/2025	225A	Bankcard fees golf range balls	45.81	Palmer Hills Golf Course	Parks & Recreation	5600-0711-55032	
VESTIS	4/16/2025	129600	3/21/2025	6150519139	Laundry Services - towels/aprons/mats	25.00	Palmer Hills Golf Course	Parks & Recreation	5600-0715-55081	

Bettendorf City Council AP Disbursements - 04.15.25

Vendor Name	Check Date	Check #	Invoice Date	Invoice #	Memo	Amount	Fund	Dept	Account #	Project
VESTIS	4/16/2025	129600	3/21/2025	6150519142	Frist Aid Service	29.98	Palmer Hills Golf Course	Parks & Recreation	5600-0715-56010	
RIVER CITY TURF & ORNAMENTAL	4/9/2025	129507	3/13/2025	66031639	Stump Killer - 1 Quart	12.40	Palmer Hills Golf Course	Parks & Recreation	5600-0715-56025	
RIVER CITY TURF & ORNAMENTAL	4/9/2025	129507	3/13/2025	66031639	Verve Growth Regulator - 10 gallons	194.00	Palmer Hills Golf Course	Parks & Recreation	5600-0715-56025	
						13,551.70	Palmer Hills Golf Course Total			
GENERAL CONSTRUCTORS, INC.	4/16/2025	129539	3/31/2025	230257 23	The Landing Project	-	Aquatic Center Fund	Capital Projects	5750-5059-55081	Splash Landing Replcmnt
						-	Aquatic Center Fund Total			
IOWA DEPARTMENT OF REVENUE	2/28/2025	2500537	1/31/2025	0-007-731-601	Monthly Return Jan	9,637.78	Storm Water Utility	Balance Sheet	5800-0000-20401	
MERCHANT SERVICES	2/3/2025	2500534	1/31/2025	125A	Bankcard fees strm	3,518.92	Storm Water Utility	Finance	5800-0219-55032	
MERCHANT SERVICES	3/3/2025	2500538	2/28/2025	225A	Bankcard fees strm	8,032.88	Storm Water Utility	Finance	5800-0219-55032	
MIDWEST MAILWORKS INC.	4/16/2025	129562	3/28/2025	254385	03 LATE NOTICES	94.68	Storm Water Utility	Finance	5800-0219-55081	
TYLER TECHNOLOGIES	4/16/2025	129595	3/31/2025	025-503406	INSITE TRANACTIONS 01/01/25-03/31/2025	2,606.00	Storm Water Utility	Finance	5800-0219-55023	
PETTY CASH/CITY ANNEX	4/16/2025	129568	3/7/2025	25-021	Mileage for ISALT Training	85.40	Storm Water Utility	Public Works	5800-0582-53004	
ADVANCED WILDLIFE CONTROL COMPANY	4/16/2025	129513	3/31/2025	033125SW	Inspection Fee	175.00	Storm Water Utility	Public Works	5800-0584-55081	
STIVERS FORD	4/16/2025	129590	4/2/2025	F52693		61,161.50	Storm Water Utility	Public Works	5800-0599-57074	
TRUCK EQUIPMENT INC.	4/9/2025	129508	4/2/2025	317434	boom crane for new Ford F450 truck	12,660.00	Storm Water Utility	Public Works	5800-0599-57074	
AMERICORE LLC	4/16/2025	129516	3/31/2025	240250 4	Contract 2024 Intake Repair Program	35,055.00	Storm Water Utility	Capital Projects	5800-5059-55081	Intake Repair 2024
						133,027.16	Storm Water Utility Total			
RIVER BEND TRANSIT	4/16/2025	129580	2/1/2025	103124D	October Paratransit Service Revised	231.00	Transit	Public Works	5850-0500-47231	
RIVER BEND TRANSIT	4/16/2025	129580	3/31/2025	033125SS	Fares Collected	(75.04)	Transit	Public Works	5850-0500-47232	
RIVER BEND TRANSIT	4/16/2025	129580	3/31/2025	033125PT	Fares Collected	(2,227.00)	Transit	Public Works	5850-0500-47231	
MERCHANT SERVICES	2/3/2025	2500534	1/31/2025	125A	Bankcard fees 50% pw	22.32	Transit	Public Works	5850-0507-55032	
MERCHANT SERVICES	3/3/2025	2500538	2/28/2025	225A	Bankcard fees 50% pw	22.61	Transit	Public Works	5850-0507-55032	
PETTY CASH/CITY ANNEX	4/16/2025	129568	2/28/2025	25-016	CDL Reimb - Scott Downing	30.00	Transit	Public Works	5850-0507-56007	
PETTY CASH/CITY ANNEX	4/9/2025	129506	3/26/2025	25-022	CDL Reimb for John Reynolds	50.00	Transit	Public Works	5850-0507-56007	
RIVER BEND TRANSIT	4/16/2025	129580	3/31/2025	033125SS	Saturday Service	8,827.14	Transit	Public Works	5850-0507-55029	
RIVER BEND TRANSIT	4/16/2025	129580	3/31/2025	033125PT	Paratransit Service	37,729.91	Transit	Public Works	5850-0507-55028	
SCOTT COUNTY EMERGENCY MANAGEMENT	4/16/2025	129587	3/31/2025	2025-00000007	10 RADIO ACCESS FEES 3RD QTR FY25	750.00	Transit	Public Works	5850-0507-55021	
SCOTT COUNTY EMERGENCY MANAGEMENT	4/16/2025	129587	3/31/2025	2025-00000001	P25 RADIO ACCESS FEES 10 RADIOS CLY24	3,000.00	Transit	Public Works	5850-0507-55021	
DULTMEIER SALES LLC	4/16/2025	129535	3/31/2025	4227014	Bus Wash Bay Hose	168.00	Transit	Public Works	5850-0547-54006	
						48,528.94	Transit Total			
1ST AYD CORPORATION	4/16/2025	129510	3/21/2025	PSI772786	Operating supplies	147.54	Municipal Garage	Public Works	6830-0520-56007	
	4/16/2025	129521	3/28/2025	230129556	stock tires	658.32	Municipal Garage	Public Works	6830-0520-56024	
DULTMEIER SALES LLC	4/16/2025	129535	3/28/2025	4226390	STK Gauge	71.00	Municipal Garage	Public Works	6830-0520-56024	
GREEN BUICK GMC INC.	4/16/2025	129542	3/26/2025	164642	hood latch	188.75	Municipal Garage	Public Works	6830-0520-56024	
GREEN BUICK GMC INC.	4/16/2025	129542	4/3/2025	164712	STK Pads & Filters	262.46	Municipal Garage	Public Works	6830-0520-56024	
INTERSTATE BATTERY OF THE	4/16/2025	129546	4/2/2025	10065918	Stk Bolt	223.63	Municipal Garage	Public Works	6830-0520-56024	
	4/16/2025	129546	4/3/2025	290070	STK Battery	835.84	Municipal Garage	Public Works	6830-0520-56024	
KILBURG EQUIPMENT, LLC.	4/16/2025	129551	4/1/2025	4775	Deflector STK	233.71	Municipal Garage	Public Works	6830-0520-56024	
LAWSON PRODUCTS, INC.	4/16/2025	129554	3/24/2025	9312337528	operating supplies	611.31	Municipal Garage	Public Works	6830-0520-56007	
LINDQUIST FORD, INC.	4/16/2025	129557	1/10/2025	273352	Repair 2317	35.40	Municipal Garage	Public Works	6830-0520-54004	
LINDQUIST FORD, INC.	4/16/2025	129557	3/28/2025	391592	stock 02 sensor	308.18	Municipal Garage	Public Works	6830-0520-56024	
MACQUEEN EQUIPMENT	4/16/2025	129559	3/10/2025	P26302	switch	148.23	Municipal Garage	Public Works	6830-0520-56024	
MACQUEEN EQUIPMENT	4/16/2025	129559	3/18/2025	P26416	curtain - 2304	128.19	Municipal Garage	Public Works	6830-0520-56024	
MACQUEEN EQUIPMENT	4/16/2025	129559	3/18/2025	P26425	STK Valve	128.82	Municipal Garage	Public Works	6830-0520-56024	
MACQUEEN EQUIPMENT	4/16/2025	129559	3/18/2025	P26424	stock wind mount	715.22	Municipal Garage	Public Works	6830-0520-56024	
MACQUEEN EQUIPMENT	4/16/2025	129559	3/19/2025	P26434	stock guide block	143.17	Municipal Garage	Public Works	6830-0520-56024	
MACQUEEN EQUIPMENT	4/16/2025	129559	3/19/2025	P26445	stock fittings	734.17	Municipal Garage	Public Works	6830-0520-56024	
MACQUEEN EQUIPMENT	4/16/2025	129559	3/20/2025	P26467	STK Bolts	30.85	Municipal Garage	Public Works	6830-0520-56024	
MACQUEEN EQUIPMENT	4/16/2025	129559	3/20/2025	P26470	stock front curtain	186.88	Municipal Garage	Public Works	6830-0520-56024	
MACQUEEN EQUIPMENT	4/16/2025	129559	3/25/2025	P26509	stock curtain	79.50	Municipal Garage	Public Works	6830-0520-56024	
MACQUEEN EQUIPMENT	4/16/2025	129559	3/27/2025	P26542	STK Guide Block	125.97	Municipal Garage	Public Works	6830-0520-56024	
MACQUEEN EQUIPMENT	4/16/2025	129559	3/27/2025	P26541	STK Light Bar	488.65	Municipal Garage	Public Works	6830-0520-56024	
MILLS CHEVROLET COMPANY	4/16/2025	129563	3/13/2025	6015068	Oil Change 2320	84.53	Municipal Garage	Public Works	6830-0520-54004	
MILLS CHEVROLET COMPANY	4/16/2025	129563	4/1/2025	6036533	Washer Pump Repair	441.37	Municipal Garage	Public Works	6830-0520-54004	
NAPA - DAVENPORT	4/16/2025	129565	3/21/2025	879525	switch 0513	37.06	Municipal Garage	Public Works	6830-0520-56024	
NAPA - DAVENPORT	4/16/2025	129565	3/26/2025	879967	operating supplies	22.08	Municipal Garage	Public Works	6830-0520-56007	

Bettendorf City Council AP Disbursements - 04.15.25

Vendor Name	Check Date	Check #	Invoice Date	Invoice #	Memo	Amount	Fund	Dept	Account #	Project
NAPA - DAVENPORT	4/16/2025	129565	3/27/2025	880125	fuse holders	12.68	Municipal Garage	Public Works	6830-0520-56024	
	4/16/2025	129565	3/27/2025	880104	bulbs	29.37	Municipal Garage	Public Works	6830-0520-56024	
NAPA - DAVENPORT	4/16/2025	129565	3/27/2025	880107	stock filters	36.00	Municipal Garage	Public Works	6830-0520-56024	
NAPA - DAVENPORT	4/16/2025	129565	3/28/2025	880209	stock wipers	209.25	Municipal Garage	Public Works	6830-0520-56024	
NAPA - DAVENPORT	4/16/2025	129565	4/3/2025	880862	Operating Supplies	109.92	Municipal Garage	Public Works	6830-0520-56007	
NAPA - DAVENPORT	4/16/2025	129565	4/3/2025	880862	STK Filter & Grease	125.92	Municipal Garage	Public Works	6830-0520-56024	
NOTT COMPANY	4/16/2025	129566	3/12/2025	5081318-00	hose for 1801	710.95	Municipal Garage	Public Works	6830-0520-56024	
PETTY CASH/CITY ANNEX	4/16/2025	129568	2/25/2025	25-015	CDL Reimb - Kevin Kludy	32.00	Municipal Garage	Public Works	6830-0520-56007	
REXCO EQUIPMENT CO.	4/16/2025	129578	3/26/2025	P49969	latches for 1114	75.67	Municipal Garage	Public Works	6830-0520-56024	
RILCO FLUID CARE, INC.	4/16/2025	129579	3/27/2025	553113	DEF	429.00	Municipal Garage	Public Works	6830-0520-56035	
ROCKFORD RIGGING INC.	4/16/2025	129585	3/20/2025	0651152-IN	chain - 2203	321.45	Municipal Garage	Public Works	6830-0520-56024	
S J SMITH CO. INC.	4/16/2025	129586	3/14/2025	6764755	operating supplies	210.50	Municipal Garage	Public Works	6830-0520-56007	
TERMINAL SUPPLY COMPANY	4/16/2025	129591	4/3/2025	19449-00	Operating Supplies	108.07	Municipal Garage	Public Works	6830-0520-56007	
TERMINAL SUPPLY COMPANY	4/16/2025	129591	4/3/2025	19449-00	STK Light	81.96	Municipal Garage	Public Works	6830-0520-56024	
ASCENDANCE TRUCKS LLC	4/16/2025	129518	3/27/2025	XA353000939:01	STK Cable	235.92	Municipal Garage	Public Works	6830-0520-56024	
ASCENDANCE TRUCKS LLC	4/16/2025	129518	3/28/2025	XA353000968:01	STK Trim	26.27	Municipal Garage	Public Works	6830-0520-56024	
ASCENDANCE TRUCKS LLC	4/16/2025	129518	3/28/2025	XA353000967:01	STK Glass	157.76	Municipal Garage	Public Works	6830-0520-56024	
ASCENDANCE TRUCKS LLC	4/16/2025	129518	3/31/2025	XA353000968:02	stock regulator	2,077.84	Municipal Garage	Public Works	6830-0520-56024	
ASCENDANCE TRUCKS LLC	4/16/2025	129518	4/2/2025	XA353001044:01	STK Horn	195.09	Municipal Garage	Public Works	6830-0520-56024	
						12,256.45	Municipal Garage Total			
RIVERBEND SIGNWORKS	4/16/2025	129581	4/4/2025	19411	Bus 2414 Damage Vinyl Wrap Removal - 2/12/25 Accident	260.00	Risk Management	Mayor & Council	6840-0105-55042	
						260.00	Risk Management Total			
WELLMARK BLUE CROSS & BLUE SHIELD	3/3/2025	2500535	1/31/2025	1312025	Pharmacy Rebates	(11,578.90)	Employee Insurance	Mayor & Council	6860-0100-47621	
DELTA DENTAL	3/17/2025	2500541	3/10/2025	3520500000202500	DENTAL CLAIMS 03/04 - 03/10	2,036.83	Employee Insurance	Mayor & Council	6860-0106-55076	
DELTA DENTAL	3/24/2025	2500553	3/17/2025	3520500000202500	DENTAL CLAIMS 03/11-03/17	7,179.84	Employee Insurance	Mayor & Council	6860-0106-55076	
DELTA DENTAL	3/24/2025	2500555	3/24/2025	3520500000202500	DENTAL CLAIMS 03/18-03/24	7,173.35	Employee Insurance	Mayor & Council	6860-0106-55076	
EMPLOYEE BENEFIT SYSTEM	4/16/2025	129538	3/20/2025	47072	April 2025 monthly billing, INV 47072	868.66	Employee Insurance	Mayor & Council	6860-0106-55065	
EMPLOYEE BENEFIT SYSTEM	3/27/2025	2500545	3/26/2025	3262025	vision claims cks 2763-2768	1,523.20	Employee Insurance	Mayor & Council	6860-0106-55078	
ROCK VALLEY PHYSICAL THERAPY	4/16/2025	129584	4/1/2025	356	March 2025 Wellness, INV 00356	1,152.07	Employee Insurance	Mayor & Council	6860-0106-55079	
WAGWORKS	3/26/2025	2500536	2/24/2025	INV7552335	Admin Fees	322.50	Employee Insurance	Mayor & Council	6860-0106-55065	
WELLMARK BLUE CROSS & BLUE SHIELD	3/3/2025	2500535	1/31/2025	1312025	stop loss reimbursement	(1,119.48)	Employee Insurance	Mayor & Council	6860-0106-55064	
WELLMARK BLUE CROSS & BLUE SHIELD	3/3/2025	2500535	1/31/2025	1312025	admin fees JAN	14,842.30	Employee Insurance	Mayor & Council	6860-0106-55065	
WELLMARK BLUE CROSS & BLUE SHIELD	3/3/2025	2500535	1/31/2025	1312025	Aggregate Jan	1,404.32	Employee Insurance	Mayor & Council	6860-0106-55066	
WELLMARK BLUE CROSS & BLUE SHIELD	3/3/2025	2500535	1/31/2025	1312025	Specific Jan	48,152.98	Employee Insurance	Mayor & Council	6860-0106-55067	
WELLMARK BLUE CROSS & BLUE SHIELD	3/3/2025	2500535	1/31/2025	1312025	Medical claims, 1/25-1/31/25	81,328.81	Employee Insurance	Mayor & Council	6860-0106-55063	
WELLMARK BLUE CROSS & BLUE SHIELD	3/3/2025	2500535	1/31/2025	1312025	Pharmacy Claims Jan	82,718.04	Employee Insurance	Mayor & Council	6860-0106-55080	
WELLMARK BLUE CROSS & BLUE SHIELD	3/3/2025	2500535	1/31/2025	1312025	Pharmacy Claims Jan	(82,718.04)	Employee Insurance	Mayor & Council	6860-0106-55063	
WELLMARK BLUE CROSS & BLUE SHIELD	4/1/2025	2500550	2/28/2025	2282025	Stop loss reimbursements	(16,690.37)	Employee Insurance	Mayor & Council	6860-0106-55064	
WELLMARK BLUE CROSS & BLUE SHIELD	4/1/2025	2500550	2/28/2025	2282025	Admin fees Feb	14,898.95	Employee Insurance	Mayor & Council	6860-0106-55065	
WELLMARK BLUE CROSS & BLUE SHIELD	4/1/2025	2500550	2/28/2025	2282025	Aggregate Feb	1,409.68	Employee Insurance	Mayor & Council	6860-0106-55066	
WELLMARK BLUE CROSS & BLUE SHIELD	4/1/2025	2500550	2/28/2025	2282025	Specific Feb	48,336.77	Employee Insurance	Mayor & Council	6860-0106-55067	
WELLMARK BLUE CROSS & BLUE SHIELD	4/1/2025	2500550	2/28/2025	2282025	Medical claims, 2/22-2/28/25	148,025.96	Employee Insurance	Mayor & Council	6860-0106-55063	
WELLMARK BLUE CROSS & BLUE SHIELD	4/1/2025	2500550	2/28/2025	2282025	Pharmacy Claims Feb	99,668.45	Employee Insurance	Mayor & Council	6860-0106-55080	
WELLMARK BLUE CROSS & BLUE SHIELD	4/1/2025	2500550	2/28/2025	2282025	Pharmacy Claims Feb	(99,668.45)	Employee Insurance	Mayor & Council	6860-0106-55063	
WELLMARK BLUE CROSS & BLUE SHIELD	3/21/2025	2500552	3/8/2025	3142025		75,153.73	Employee Insurance	Mayor & Council	6860-0106-55063	
WELLMARK BLUE CROSS & BLUE SHIELD	3/28/2025	2500554	3/21/2025	30212025		75,198.70	Employee Insurance	Mayor & Council	6860-0106-55063	
YMCA OF IOWA MISSISSIPPI VALLEY	4/16/2025	129604	3/31/2025	3/2025-BETT	March 2025 member dues, INV 3/2025-BETT	2,780.00	Employee Insurance	Mayor & Council	6860-0106-55079	
						502,399.90	Employee Insurance Total			
	4/16/2025	129527	3/27/2025	SA12965	NexusWorx yearly software as a subscription fee for fiber	9,080.00	Information Services	Finance	6880-0231-55023	PUBLIC WORKS (GEN) IT
DAVENPORT ELECTRIC CONTRACT	4/16/2025	129534	3/14/2025	56938	Add 5 network ports to spot on the wall where the library wanted	1,345.16	Information Services	Finance	6880-0231-55072	LIBRARY IT
ICIMS INC.	4/9/2025	129501	4/3/2025	INV-ICI-289956	ICIMS Data Retention	5,065.00	Information Services	Finance	6880-0231-55023	
IT SAVVY	4/9/2025	129502	1/16/2025	1544793	Backup Exec 7 yearly license subscriptions	947.37	Information Services	Finance	6880-0231-55023	IT - Finance
ONENECK IT SOLUTIONS LLC	4/9/2025	129504	2/14/2025	INV000047644	Cisco phone subscription	1,052.50	Information Services	Finance	6880-0231-55023	IT - Finance
ONENECK IT SOLUTIONS LLC	4/9/2025	129504	2/20/2025	INV000047711	Cisco equipment vendor maintenance contract	6,209.92	Information Services	Finance	6880-0231-54020	
ONENECK IT SOLUTIONS LLC	4/2/2025	129456	3/21/2025	INV000048101	Cisco phone subscription	1,052.50	Information Services	Finance	6880-0231-55023	IT - Finance
ZENCITY TECHNOLOGIES	4/9/2025	129509	2/24/2025	si256000044	Year 2 of 3 of Zencity	18,000.00	Information Services	Finance	6880-0231-55023	IT - Economic Development

Bettendorf City Council AP Disbursements - 04.15.25

Vendor Name	Check Date	Check #	Invoice Date	Invoice #	Memo	Amount	Fund	Dept	Account #	Project
TRAVELBANK	4/16/2025	129593	3/21/2025	2025031322	Yearly Subscription 05/01/25-04/30/26	12,000.00	Information Services	Finance	6880-0231-55023	IT - Finance
TRAVELBANK	4/2/2025	129462	3/31/2025	2025033167	2 overage user charges	30.00	Information Services	Finance	6880-0231-55023	IT - Finance
	4/2/2025	129462	3/31/2025	2024123161	12/31/2025 2 overage user charges	30.00	Information Services	Finance	6880-0231-55023	IT - Finance
MGG TECHNOLOGIES INC	4/2/2025	129454	3/21/2025	US1869	Asset Management - Subscription	1,800.00	Information Services	Finance	6880-0231-55023	IT - Finance
						56,612.45	Information Services Total			
IOWA DEPARTMENT OF REVENUE	3/7/2025	2500516	3/7/2025	0-007-810-697	03/07/25 PAY DATE IA W/H TAX	22,005.67	Liability Clearing Acct.	Balance Sheet	8100-0000-21006	
IOWA DEPARTMENT OF REVENUE	3/21/2025	2500532	3/21/2025	0-007-827-135	03/21/25 PAY DATE IA W/H TAX	21,470.14	Liability Clearing Acct.	Balance Sheet	8100-0000-21006	
AFLAC	3/7/2025	2500511	3/7/2025	PR 3.7.25 CI WRAP	CI WRAP CONTRIBUTION	112.45	Liability Clearing Acct.	Balance Sheet	8100-0000-21014	
AFLAC	3/21/2025	2500533	3/21/2025	382974	AFLAC PRE TAX	2,237.00	Liability Clearing Acct.	Balance Sheet	8100-0000-21020	
AFLAC	3/21/2025	2500533	3/21/2025	382974	AFLAC AFTER TAX CONTRIBUTIONS	1,345.00	Liability Clearing Acct.	Balance Sheet	8100-0000-21014	
AFLAC	3/21/2025	2500523	3/21/2025	PR 3.21.25 Ci wrap	CI WRAP CONTRIBUTION	112.45	Liability Clearing Acct.	Balance Sheet	8100-0000-21014	
AMERICAN FUNDS ROTH IRA WIRE	3/7/2025	2500521	3/7/2025	7972-3935-54117	AFTER TAX ROTH IRA CONTRIBUTIONS	25.00	Liability Clearing Acct.	Balance Sheet	8100-0000-21014	
AMERICAN FUNDS ROTH IRA WIRE	3/21/2025	2500524	3/21/2025	PR 3.21.25	AFTER TAX ROTH IRA CONTRIBUTIONS	25.00	Liability Clearing Acct.	Balance Sheet	8100-0000-21014	
AMERICAN FUNDS ROTH IRA WIRE	4/4/2025	129465	4/4/2025	PR 04.04.25 AM FUNDS	AMERICAN FUNDS EMPLOYEE DEDUCTION	50.00	Liability Clearing Acct.	Balance Sheet	8100-0000-21014	
ANCHOR NATIONAL LIFE INSURANCE CO	4/4/2025	129466	4/4/2025	PR 04.04.25 AIG	ANCHOR LIFE INSURANCE	232.84	Liability Clearing Acct.	Balance Sheet	8100-0000-21020	
BETTENDORF POLICE BENEVOLENT FUND	3/7/2025	2500514	3/7/2025	PR 3.7.25 BENVLT FUND	03/07/25 PR CONTRIBUTIONS	96.00	Liability Clearing Acct.	Balance Sheet	8100-0000-21029	
BETTENDORF POLICE BENEVOLENT FUND	3/21/2025	2500527	3/21/2025	PR 3.21.25 BenvInt Fund	03/21/25 PR CONTRIBUTIONS	96.00	Liability Clearing Acct.	Balance Sheet	8100-0000-21029	
CITY OF BETTENDORF	4/4/2025	129467	4/4/2025	PR 04.04.25 COB	EMPLOYEE INSURANCE PREM DEDUCTIONS	20,229.93	Liability Clearing Acct.	Balance Sheet	8100-0000-21018	
CITY OF BETTENDORF	4/4/2025	129467	4/4/2025	PR 04.04.25 COB	ORTHO	135.00	Liability Clearing Acct.	Balance Sheet	8100-0000-21019	
CITY OF BETTENDORF	4/4/2025	129467	4/4/2025	PR 04.04.25 COB	FLEX SPENDING	5,491.52	Liability Clearing Acct.	Balance Sheet	8100-0000-21020	
CITY OF BETTENDORF	4/4/2025	129467	4/4/2025	PR 04.04.25 COB	DEPENDENT CARE	1,922.70	Liability Clearing Acct.	Balance Sheet	8100-0000-21020	
CITY OF BETTENDORF	4/4/2025	129467	4/4/2025	PR 04.04.25 COB	PREM PASS THRU	2,140.66	Liability Clearing Acct.	Balance Sheet	8100-0000-21020	
CITY OF BETTENDORF	4/4/2025	129467	4/4/2025	PR 04.04.25 COB	COMPUTER LOAN	77.23	Liability Clearing Acct.	Balance Sheet	8100-0000-21029	
COLLECTION SERVICES CENTER	3/7/2025	2500520	3/7/2025	2576562	CHILD/SPOUSE SUPPORT	1,825.70	Liability Clearing Acct.	Balance Sheet	8100-0000-21016	
COLLECTION SERVICES CENTER	3/21/2025	2500528	3/21/2025	2582581	CHILD/SPOUSE SUPPORT	1,825.70	Liability Clearing Acct.	Balance Sheet	8100-0000-21016	
GREAT AMERICAN PLAN ADMINISTRATORS	3/7/2025	2500512	3/7/2025	PR 3.7.25 GREAT AMERICAN	03/07/25 PR CONTRIBUTIONS	692.34	Liability Clearing Acct.	Balance Sheet	8100-0000-21020	
GREAT AMERICAN PLAN ADMINISTRATORS	3/21/2025	2500529	3/21/2025	PR 3.21.25 Great American	03/21/25 PR CONTRIBUTIONS	721.10	Liability Clearing Acct.	Balance Sheet	8100-0000-21020	
ICMA RETIREMENT TRUST - 457	3/7/2025	2500509	3/7/2025	7708384	ICMA ROTH AFTER TAX	5,690.02	Liability Clearing Acct.	Balance Sheet	8100-0000-21014	
ICMA RETIREMENT TRUST - 457	3/7/2025	2500508	3/7/2025	6396085	457 LOAN PAYMENTS	4,062.52	Liability Clearing Acct.	Balance Sheet	8100-0000-21023	
ICMA RETIREMENT TRUST - 457	3/7/2025	2500508	3/7/2025	6396085	457 CONTRIBUTION PAYMENTS	62,142.90	Liability Clearing Acct.	Balance Sheet	8100-0000-21020	
ICMA RETIREMENT TRUST - 457	3/7/2025	2500508	3/7/2025	6396085	457 B ROTH	3,139.73	Liability Clearing Acct.	Balance Sheet	8100-0000-21014	
ICMA RETIREMENT TRUST - 457	3/11/2025	2500551	3/7/2025	6396085-B	457 LOAN PAYMENT- CORRECTION FOR LOAN SHORTAGE	2.08	Liability Clearing Acct.	Balance Sheet	8100-0000-21023	
ICMA RETIREMENT TRUST - 457	3/21/2025	2500526	3/21/2025	6910771	ICMA ROTH AFTER TAX	5,644.22	Liability Clearing Acct.	Balance Sheet	8100-0000-21014	
ICMA RETIREMENT TRUST - 457	3/21/2025	2500548	3/21/2025	7605788	457 LOAN PAYMENTS	4,036.52	Liability Clearing Acct.	Balance Sheet	8100-0000-21023	
ICMA RETIREMENT TRUST - 457	3/21/2025	2500548	3/21/2025	7605788	457 CONTRIBUTION PAYMENTS	62,068.52	Liability Clearing Acct.	Balance Sheet	8100-0000-21020	
ICMA RETIREMENT TRUST - 457	3/21/2025	2500548	3/21/2025	7605788	457 B ROTH	2,908.33	Liability Clearing Acct.	Balance Sheet	8100-0000-21014	
ILLINOIS DEPARTMENT OF REVENUE	3/7/2025	2500517	3/7/2025	1-713-919-408	ILLINOIS STATE W/H TAX	3,659.56	Liability Clearing Acct.	Balance Sheet	8100-0000-21007	
ILLINOIS DEPARTMENT OF REVENUE	3/21/2025	2500530	3/21/2025	0-826-039-728	ILLINOIS STATE W/H TAX	3,581.61	Liability Clearing Acct.	Balance Sheet	8100-0000-21007	
INTERNAL REVENUE SERVICE	3/7/2025	2500515	3/7/2025	43157760	FEDERAL W/H	88,255.39	Liability Clearing Acct.	Balance Sheet	8100-0000-21005	
INTERNAL REVENUE SERVICE	3/7/2025	2500515	3/7/2025	43157760	FICA W/H TAX	76,896.82	Liability Clearing Acct.	Balance Sheet	8100-0000-21008	
INTERNAL REVENUE SERVICE	3/7/2025	2500515	3/7/2025	43157760	MEDICARE W/H TAX	28,588.20	Liability Clearing Acct.	Balance Sheet	8100-0000-21009	
IOWA C.O.P.S.	3/7/2025	2500513	3/7/2025	PR 3.7.25 IA COPS	03/07/25 PR CONTRIBUTIONS	35.00	Liability Clearing Acct.	Balance Sheet	8100-0000-21029	
IOWA C.O.P.S.	3/21/2025	2500525	3/21/2025	PR 3.21.25 IA cops	03/21/25 PR CONTRIBUTIONS	35.00	Liability Clearing Acct.	Balance Sheet	8100-0000-21029	
IPERS COLLECTIONS	3/7/2025	2500518	3/7/2025	03.07.25 IPERS	EMPLOYEE SHARE IPERS	38,712.11	Liability Clearing Acct.	Balance Sheet	8100-0000-21010	
IPERS COLLECTIONS	3/7/2025	2500518	3/7/2025	03.07.25 IPERS	CITY SHARE IPERS	58,098.90	Liability Clearing Acct.	Balance Sheet	8100-0000-21010	
LEGALSHIELD	4/4/2025	129470	4/4/2025	PR 04.04.25 LEGALSHIELD	LEGALSHIELD	55.83	Liability Clearing Acct.	Balance Sheet	8100-0000-21014	
LINCOLN LIFE	4/4/2025	129468	4/4/2025	PR 04.04.25 LINCOLN	LINCOLN LIFE INSURANCE	915.10	Liability Clearing Acct.	Balance Sheet	8100-0000-21020	
MUNICIPAL FIRE & POLICE	3/7/2025	2500510	3/7/2025	3/7/2025 MFPRSI	EMPLOYEE SHARE POLICE PENSION	17,565.90	Liability Clearing Acct.	Balance Sheet	8100-0000-21011	
MUNICIPAL FIRE & POLICE	3/7/2025	2500510	3/7/2025	3/7/2025 MFPRSI	CITY SHARE POLICE PENSION	41,679.90	Liability Clearing Acct.	Balance Sheet	8100-0000-21003	
MUNICIPAL FIRE & POLICE	3/7/2025	2500510	3/7/2025	3/7/2025 MFPRSI	EMP SHARE FIRE PENSION	13,205.02	Liability Clearing Acct.	Balance Sheet	8100-0000-21012	
MUNICIPAL FIRE & POLICE	3/7/2025	2500510	3/7/2025	3/7/2025 MFPRSI	CITY SHARE FIRE PENSION	31,332.63	Liability Clearing Acct.	Balance Sheet	8100-0000-21004	
MUNICIPAL FIRE & POLICE	3/21/2025	2500549	3/21/2025	PR 3.21.25 MFPRSI	EMPLOYEE SHARE POLICE PENSION	16,941.45	Liability Clearing Acct.	Balance Sheet	8100-0000-21011	
MUNICIPAL FIRE & POLICE	3/21/2025	2500549	3/21/2025	PR 3.21.25 MFPRSI	CITY SHARE POLICE PENSION	40,198.23	Liability Clearing Acct.	Balance Sheet	8100-0000-21003	
MUNICIPAL FIRE & POLICE	3/21/2025	2500549	3/21/2025	PR 3.21.25 MFPRSI	EMP SHARE FIRE PENSION	12,518.66	Liability Clearing Acct.	Balance Sheet	8100-0000-21012	
MUNICIPAL FIRE & POLICE	3/21/2025	2500549	3/21/2025	PR 3.21.25 MFPRSI	CITY SHARE FIRE PENSION	29,704.00	Liability Clearing Acct.	Balance Sheet	8100-0000-21004	
NATIONWIDE RETIREMENT SOLUTIONS	3/7/2025	2500519	3/7/2025	PR 3.7.25 NATIONWIDE	457 CONTRIBUTIONS	763.00	Liability Clearing Acct.	Balance Sheet	8100-0000-21020	

Bettendorf City Council AP Disbursements - 04.15.25

Vendor Name	Check Date	Check #	Invoice Date	Invoice #	Memo	Amount	Fund	Dept	Account #	Project
NATIONWIDE RETIREMENT SOLUTIONS	3/21/2025	2500531	3/21/2025	PR. 3.21.25 NATIONWIDE	457 CONTRIBUTIONS	763.00	Liability Clearing Acct.	Balance Sheet	8100-0000-21020	
PACIFIC LIFE INSURANCE COMPANY	4/4/2025	129469	4/4/2025	PR 04.04.25 PACIFIC	PACIFIC LIFE INSURANCE	312.33	Liability Clearing Acct.	Balance Sheet	8100-0000-21020	
STATE DISBURSEMENT UNIT	4/4/2025	129472	4/4/2025	PR 04.04.25 IL CHILD SUPPORT	IL CHILD SUPPORT DEDUCTIONS FROM EMPLOYEES	925.48	Liability Clearing Acct.	Balance Sheet	8100-0000-21016	
UNITED WAY QUAD CITIES	3/7/2025	2500507	3/7/2025	PR 3.7.25 UNITED WAY	03/07/25 PR CONTRIBUTIONS	756.00	Liability Clearing Acct.	Balance Sheet	8100-0000-21017	
UNITED WAY QUAD CITIES	3/21/2025	2500522	3/21/2025	PR 3.21.25 United way	3/21/25 PR CONTRIBUTIONS	756.00	Liability Clearing Acct.	Balance Sheet	8100-0000-21017	
WASHINGTON NATIONAL LIFE INSURANCE	4/4/2025	129471	4/4/2025	PR 04.04.25 WASHINGTON	WASHINGTON MUTUAL LIFE INSURANCE EMPLOYEE	61.10	Liability Clearing Acct.	Balance Sheet	8100-0000-21014	
						738,880.49	Liability Clearing Acct. Total			

Bettendorf City QCWCC AP Disbursements - 04.15.25

Vendor Name	Check Date	Check #	Invoice Date	Invoice #	Memo	Amount	Fund	Dept	Account #
IOWA DEPARTMENT OF REVENUE	3/25/2025	2500544	3/24/2025	0-008-048-740	Sales Tax 02/01-02/28/25	6,785.09	QC Waterfront Convention	Balance Sheet	5900-0000-20401
						6,785.09		Balance Sheet Total	
ADVANCED BUSINESS SYSTEMS, INC	4/9/2025	3737	3/20/2025	INV413140	QCWCC Printer	289.62	QC Waterfront Convention	QCWCC	5900-2001-56006
IOWA AMERICAN WATER COMPANY	4/16/2025	3738	3/26/2025	689142MAR25	WATER BILL	371.60	QC Waterfront Convention	QCWCC	5900-2001-54011
MID AMERICAN ENERGY	4/16/2025	3739	3/31/2025	565094003	POWER BILL QCWCC	28.30	QC Waterfront Convention	QCWCC	5900-2001-54008
MID AMERICAN ENERGY	4/16/2025	3739	3/31/2025	565085760	POWER BILL QCWCC	8,612.03	QC Waterfront Convention	QCWCC	5900-2001-54008
REPUBLIC SERVICES	4/16/2025	3740	3/20/2025	0400-002417597	garbage	677.60	QC Waterfront Convention	QCWCC	5900-2001-55072
ROCHESTER ARMORED CAR CO., INC.	4/16/2025	3741	3/31/2025	172960a	QCWCC armored car	86.64	QC Waterfront Convention	QCWCC	5900-2001-55081
THE GREEN THUMBERS	4/16/2025	3742	4/2/2025	1-839611	plant maint	325.00	QC Waterfront Convention	QCWCC	5900-2001-55081
						10,390.79		QCWCC Total	
									--
						17,175.88		Grand Total	

Bettendorf Public Library AP Disbursements - 04.09.25

Vendor Name	Check Date	Check #	Invoice Date	Invoice #	Memo	Amount	Fund	Dept	Account #	Project #
U.S. POSTAL SERVICE	4/9/2025	129497	3/20/2025	Permit92025	2025 Permit 9	350.00	General Fund	Library Administration	1001-0601-56008	N/A
U.S. POSTAL SERVICE	4/9/2025	129497	3/18/2025	PostageDue2025-03	Postage Due Deposit	200.00	General Fund	Customer Services	1001-0610-56008	N/A
AMAZON.COM	4/9/2025	129474	3/8/2025	1RJG-PGCD-QNRT	Juvenile	11.96	General Fund	Bus. Type Capital Outlay	1001-0680-57085	N/A
AMAZON.COM	4/9/2025	129474	3/11/2025	1XC9-9T6R-314X	Juvenile	20.65	General Fund	Bus. Type Capital Outlay	1001-0680-57085	N/A
AMAZON.COM	4/9/2025	129474	3/18/2025	1XNF-9K3T-NM4N	Adult Nonfiction	15.98	General Fund	Bus. Type Capital Outlay	1001-0680-57080	N/A
AMAZON.COM	4/9/2025	129474	3/21/2025	1JT7-RXGT-KR1Y	Adult Nonfiction	11.31	General Fund	Bus. Type Capital Outlay	1001-0680-57080	N/A
AMAZON.COM	4/9/2025	129474	3/26/2025	1MCJ-D3N7-3P1N	Juvenile	152.73	General Fund	Bus. Type Capital Outlay	1001-0680-57085	N/A
BLACKSTONE PUBLISHING	4/9/2025	129476	3/6/2025	2190232	Audio	35.99	General Fund	Bus. Type Capital Outlay	1001-0680-57086	N/A
BLACKSTONE PUBLISHING	4/9/2025	129476	3/7/2025	2190354	Audio	112.47	General Fund	Bus. Type Capital Outlay	1001-0680-57086	N/A
BLACKSTONE PUBLISHING	4/9/2025	129476	3/18/2025	2191661	Audio	71.98	General Fund	Bus. Type Capital Outlay	1001-0680-57086	N/A
EBSCO SUBSCRIPTION SERVICES	4/9/2025	129477	3/13/2025	2503934	Print Subscriptions	17.99	General Fund	Bus. Type Capital Outlay	1001-0680-57077	N/A
GALE GROUP, THE	4/9/2025	129479	3/4/2025	86967877	Adult Fiction	173.94	General Fund	Bus. Type Capital Outlay	1001-0680-57081	N/A
GALE GROUP, THE	4/9/2025	129479	3/4/2025	86967569	Adult Fiction	225.67	General Fund	Bus. Type Capital Outlay	1001-0680-57081	N/A
GALE GROUP, THE	4/9/2025	129479	3/5/2025	86972997	Adult Fiction	175.44	General Fund	Bus. Type Capital Outlay	1001-0680-57081	N/A
GALE GROUP, THE	4/9/2025	129479	3/7/2025	86988798	Adult Fiction	49.48	General Fund	Bus. Type Capital Outlay	1001-0680-57081	N/A
GALE GROUP, THE	4/9/2025	129479	3/7/2025	86988444	Adult Fiction	74.22	General Fund	Bus. Type Capital Outlay	1001-0680-57081	N/A
GALE GROUP, THE	4/9/2025	129479	3/7/2025	86987938	Adult Fiction	80.22	General Fund	Bus. Type Capital Outlay	1001-0680-57081	N/A
GALE GROUP, THE	4/9/2025	129479	3/19/2025	87047281	Adult Fiction	79.47	General Fund	Bus. Type Capital Outlay	1001-0680-57081	N/A
GALE GROUP, THE	4/9/2025	129479	3/20/2025	87056239	Adult Fiction	30.74	General Fund	Bus. Type Capital Outlay	1001-0680-57081	N/A
GALE GROUP, THE	4/9/2025	129479	3/20/2025	87056754	Adult Fiction	111.71	General Fund	Bus. Type Capital Outlay	1001-0680-57081	N/A
GALE GROUP, THE	4/9/2025	129479	3/20/2025	87057278	Adult Fiction	116.21	General Fund	Bus. Type Capital Outlay	1001-0680-57081	N/A
GALE GROUP, THE	4/9/2025	129479	3/25/2025	87082424	Adult Fiction	28.49	General Fund	Bus. Type Capital Outlay	1001-0680-57081	N/A
INGRAM LIBRARY SERVICES, LLC	4/9/2025	129482	1/1/2025	63130461	Adult Fiction	28.07	General Fund	Bus. Type Capital Outlay	1001-0680-57081	N/A
INGRAM LIBRARY SERVICES, LLC	4/9/2025	129482	1/1/2025	63131905	Adult Fiction	10.19	General Fund	Bus. Type Capital Outlay	1001-0680-57081	N/A
INGRAM LIBRARY SERVICES, LLC	4/9/2025	129482	1/1/2025	63132837	Young Adult	11.49	General Fund	Bus. Type Capital Outlay	1001-0680-57082	N/A
INGRAM LIBRARY SERVICES, LLC	4/9/2025	129481	2/11/2025	63148726	Adult Fiction	85.89	General Fund	Bus. Type Capital Outlay	1001-0680-57081	N/A
INGRAM LIBRARY SERVICES, LLC	4/9/2025	129482	3/4/2025	63155012	Young Adult	21.23	General Fund	Bus. Type Capital Outlay	1001-0680-57082	N/A
INGRAM LIBRARY SERVICES, LLC	4/9/2025	129482	3/4/2025	63155015	Juvenile	44.00	General Fund	Bus. Type Capital Outlay	1001-0680-57085	N/A
INGRAM LIBRARY SERVICES, LLC	4/9/2025	129482	3/4/2025	63155013	Adult Nonfiction	48.88	General Fund	Bus. Type Capital Outlay	1001-0680-57080	N/A
INGRAM LIBRARY SERVICES, LLC	4/9/2025	129482	3/4/2025	63155007	Juvenile	55.91	General Fund	Bus. Type Capital Outlay	1001-0680-57085	N/A
INGRAM LIBRARY SERVICES, LLC	4/9/2025	129482	3/4/2025	63155010	Juvenile	112.73	General Fund	Bus. Type Capital Outlay	1001-0680-57085	N/A
INGRAM LIBRARY SERVICES, LLC	4/9/2025	129482	3/4/2025	63155011	Young Adult	11.24	General Fund	Bus. Type Capital Outlay	1001-0680-57082	N/A
INGRAM LIBRARY SERVICES, LLC	4/9/2025	129482	3/4/2025	63155008	Juvenile	11.49	General Fund	Bus. Type Capital Outlay	1001-0680-57085	N/A
INGRAM LIBRARY SERVICES, LLC	4/9/2025	129482	3/4/2025	63155014	Juvenile	11.69	General Fund	Bus. Type Capital Outlay	1001-0680-57085	N/A
INGRAM LIBRARY SERVICES, LLC	4/9/2025	129482	3/4/2025	63155009	Adult Nonfiction	15.50	General Fund	Bus. Type Capital Outlay	1001-0680-57080	N/A
INGRAM LIBRARY SERVICES, LLC	4/9/2025	129482	3/5/2025	63155425	Juvenile	28.52	General Fund	Bus. Type Capital Outlay	1001-0680-57085	N/A
INGRAM LIBRARY SERVICES, LLC	4/9/2025	129482	3/5/2025	63155435	Adult Fiction	34.18	General Fund	Bus. Type Capital Outlay	1001-0680-57081	N/A
INGRAM LIBRARY SERVICES, LLC	4/9/2025	129482	3/5/2025	63155429	Young Adult	34.47	General Fund	Bus. Type Capital Outlay	1001-0680-57082	N/A
INGRAM LIBRARY SERVICES, LLC	4/9/2025	129482	3/5/2025	63155430	Adult Nonfiction	35.05	General Fund	Bus. Type Capital Outlay	1001-0680-57080	N/A
INGRAM LIBRARY SERVICES, LLC	4/9/2025	129482	3/5/2025	63155432	Juvenile	46.84	General Fund	Bus. Type Capital Outlay	1001-0680-57085	N/A
INGRAM LIBRARY SERVICES, LLC	4/9/2025	129482	3/5/2025	63155426	Adult Nonfiction	65.84	General Fund	Bus. Type Capital Outlay	1001-0680-57080	N/A
INGRAM LIBRARY SERVICES, LLC	4/9/2025	129482	3/5/2025	63155433	Juvenile	67.80	General Fund	Bus. Type Capital Outlay	1001-0680-57085	N/A
INGRAM LIBRARY SERVICES, LLC	4/9/2025	129482	3/5/2025	63155427	Juvenile	88.50	General Fund	Bus. Type Capital Outlay	1001-0680-57085	N/A

Bettendorf Public Library AP Disbursements - 04.09.25

Vendor Name	Check Date	Check #	Invoice Date	Invoice #	Memo	Amount	Fund	Dept	Account #	Project #
INGRAM LIBRARY SERVICES, LLC	4/9/2025	129482	3/5/2025	63155434	Juvenile	111.70	General Fund	Bus. Type Capital Outlay	1001-0680-57085	N/A
INGRAM LIBRARY SERVICES, LLC	4/9/2025	129482	3/5/2025	63155428	Juvenile	4.79	General Fund	Bus. Type Capital Outlay	1001-0680-57085	N/A
INGRAM LIBRARY SERVICES, LLC	4/9/2025	129482	3/5/2025	63155431	Juvenile	6.74	General Fund	Bus. Type Capital Outlay	1001-0680-57085	N/A
INGRAM LIBRARY SERVICES, LLC	4/9/2025	129482	3/6/2025	67794269	Adult Fiction	22.18	General Fund	Bus. Type Capital Outlay	1001-0680-57081	N/A
INGRAM LIBRARY SERVICES, LLC	4/9/2025	129482	3/6/2025	63155773	Adult Nonfiction	28.74	General Fund	Bus. Type Capital Outlay	1001-0680-57080	N/A
INGRAM LIBRARY SERVICES, LLC	4/9/2025	129482	3/6/2025	67794264	Adult Nonfiction	38.98	General Fund	Bus. Type Capital Outlay	1001-0680-57080	N/A
INGRAM LIBRARY SERVICES, LLC	4/9/2025	129482	3/6/2025	63155772	Juvenile	58.07	General Fund	Bus. Type Capital Outlay	1001-0680-57085	N/A
INGRAM LIBRARY SERVICES, LLC	4/9/2025	129482	3/6/2025	67794265	Young Adult	8.39	General Fund	Bus. Type Capital Outlay	1001-0680-57082	N/A
INGRAM LIBRARY SERVICES, LLC	4/9/2025	129482	3/6/2025	67794267	Juvenile	9.74	General Fund	Bus. Type Capital Outlay	1001-0680-57085	N/A
INGRAM LIBRARY SERVICES, LLC	4/9/2025	129482	3/6/2025	67794266	Juvenile	9.74	General Fund	Bus. Type Capital Outlay	1001-0680-57085	N/A
INGRAM LIBRARY SERVICES, LLC	4/9/2025	129482	3/6/2025	63155775	Juvenile	10.92	General Fund	Bus. Type Capital Outlay	1001-0680-57085	N/A
INGRAM LIBRARY SERVICES, LLC	4/9/2025	129482	3/6/2025	67794268	Juvenile	15.98	General Fund	Bus. Type Capital Outlay	1001-0680-57085	N/A
INGRAM LIBRARY SERVICES, LLC	4/9/2025	129482	3/6/2025	63155774	Juvenile	16.24	General Fund	Bus. Type Capital Outlay	1001-0680-57085	N/A
INGRAM LIBRARY SERVICES, LLC	4/9/2025	129482	3/6/2025	63155776	Adult Fiction	17.24	General Fund	Bus. Type Capital Outlay	1001-0680-57081	N/A
INGRAM LIBRARY SERVICES, LLC	4/9/2025	129482	3/6/2025	63155771	Adult Nonfiction	19.67	General Fund	Bus. Type Capital Outlay	1001-0680-57080	N/A
INGRAM LIBRARY SERVICES, LLC	4/9/2025	129482	3/7/2025	63156669	Juvenile	22.41	General Fund	Bus. Type Capital Outlay	1001-0680-57085	N/A
INGRAM LIBRARY SERVICES, LLC	4/9/2025	129482	3/7/2025	63156674	Adult Fiction	27.48	General Fund	Bus. Type Capital Outlay	1001-0680-57081	N/A
INGRAM LIBRARY SERVICES, LLC	4/9/2025	129482	3/7/2025	63156672	Adult Nonfiction	51.92	General Fund	Bus. Type Capital Outlay	1001-0680-57080	N/A
INGRAM LIBRARY SERVICES, LLC	4/9/2025	129482	3/7/2025	67794506	Adult Fiction	74.21	General Fund	Bus. Type Capital Outlay	1001-0680-57081	N/A
INGRAM LIBRARY SERVICES, LLC	4/9/2025	129482	3/7/2025	63156676	Young Adult	648.30	General Fund	Bus. Type Capital Outlay	1001-0680-57082	N/A
INGRAM LIBRARY SERVICES, LLC	4/9/2025	129482	3/7/2025	63156677	Young Adult	707.35	General Fund	Bus. Type Capital Outlay	1001-0680-57082	N/A
INGRAM LIBRARY SERVICES, LLC	4/9/2025	129482	3/7/2025	63156675	Adult Fiction	912.43	General Fund	Bus. Type Capital Outlay	1001-0680-57081	N/A
INGRAM LIBRARY SERVICES, LLC	4/9/2025	129482	3/7/2025	63156673	Juvenile	7.79	General Fund	Bus. Type Capital Outlay	1001-0680-57085	N/A
INGRAM LIBRARY SERVICES, LLC	4/9/2025	129482	3/7/2025	63156670	Juvenile	13.22	General Fund	Bus. Type Capital Outlay	1001-0680-57085	N/A
INGRAM LIBRARY SERVICES, LLC	4/9/2025	129482	3/7/2025	63156668	Juvenile	13.34	General Fund	Bus. Type Capital Outlay	1001-0680-57085	N/A
INGRAM LIBRARY SERVICES, LLC	4/9/2025	129482	3/10/2025	67794946	Juvenile	22.47	General Fund	Bus. Type Capital Outlay	1001-0680-57085	N/A
INGRAM LIBRARY SERVICES, LLC	4/9/2025	129482	3/10/2025	63156936	Adult Fiction	28.76	General Fund	Bus. Type Capital Outlay	1001-0680-57080	N/A
INGRAM LIBRARY SERVICES, LLC	4/9/2025	129482	3/10/2025	63156754	Adult Fiction	30.59	General Fund	Bus. Type Capital Outlay	1001-0680-57081	N/A
INGRAM LIBRARY SERVICES, LLC	4/9/2025	129482	3/10/2025	67794945	Adult Nonfiction	33.25	General Fund	Bus. Type Capital Outlay	1001-0680-57080	N/A
INGRAM LIBRARY SERVICES, LLC	4/9/2025	129482	3/10/2025	63156932	Juvenile	44.78	General Fund	Bus. Type Capital Outlay	1001-0680-57085	N/A
INGRAM LIBRARY SERVICES, LLC	4/9/2025	129482	3/10/2025	67794948	Young Adult	51.25	General Fund	Bus. Type Capital Outlay	1001-0680-57082	N/A
INGRAM LIBRARY SERVICES, LLC	4/9/2025	129482	3/10/2025	67794947	Adult Fiction	154.26	General Fund	Bus. Type Capital Outlay	1001-0680-57081	N/A
INGRAM LIBRARY SERVICES, LLC	4/9/2025	129482	3/10/2025	63156752	Juvenile	7.79	General Fund	Bus. Type Capital Outlay	1001-0680-57085	N/A
INGRAM LIBRARY SERVICES, LLC	4/9/2025	129482	3/10/2025	63156935	Young Adult	10.49	General Fund	Bus. Type Capital Outlay	1001-0680-57082	N/A
INGRAM LIBRARY SERVICES, LLC	4/9/2025	129482	3/10/2025	63156937	Adult Fiction	10.80	General Fund	Bus. Type Capital Outlay	1001-0680-57081	N/A
INGRAM LIBRARY SERVICES, LLC	4/9/2025	129482	3/10/2025	63156934	Juvenile	11.24	General Fund	Bus. Type Capital Outlay	1001-0680-57085	N/A
INGRAM LIBRARY SERVICES, LLC	4/9/2025	129482	3/10/2025	67794944	Juvenile	13.49	General Fund	Bus. Type Capital Outlay	1001-0680-57085	N/A
INGRAM LIBRARY SERVICES, LLC	4/9/2025	129482	3/10/2025	63156753	Adult Fiction	17.25	General Fund	Bus. Type Capital Outlay	1001-0680-57081	N/A
INGRAM LIBRARY SERVICES, LLC	4/9/2025	129482	3/10/2025	63156933	Juvenile	19.36	General Fund	Bus. Type Capital Outlay	1001-0680-57085	N/A
INGRAM LIBRARY SERVICES, LLC	4/9/2025	129482	3/11/2025	63157323	Adult Nonfiction	21.97	General Fund	Bus. Type Capital Outlay	1001-0680-57080	N/A
INGRAM LIBRARY SERVICES, LLC	4/9/2025	129482	3/11/2025	63157324	Juvenile	67.44	General Fund	Bus. Type Capital Outlay	1001-0680-57085	N/A
INGRAM LIBRARY SERVICES, LLC	4/9/2025	129482	3/11/2025	63157327	Juvenile	216.41	General Fund	Bus. Type Capital Outlay	1001-0680-57085	N/A
INGRAM LIBRARY SERVICES, LLC	4/9/2025	129482	3/11/2025	63157328	Juvenile	233.84	General Fund	Bus. Type Capital Outlay	1001-0680-57085	N/A
INGRAM LIBRARY SERVICES, LLC	4/9/2025	129482	3/11/2025	63157325	Adult Fiction	11.39	General Fund	Bus. Type Capital Outlay	1001-0680-57081	N/A

Bettendorf Public Library AP Disbursements - 04.09.25

Vendor Name	Check Date	Check #	Invoice Date	Invoice #	Memo	Amount	Fund	Dept	Account #	Project #
INGRAM LIBRARY SERVICES, LLC	4/9/2025	129482	3/11/2025	63157326	Adult Fiction	16.09	General Fund	Bus. Type Capital Outlay	1001-0680-57081	N/A
INGRAM LIBRARY SERVICES, LLC	4/9/2025	129481	3/12/2025	63158095	Juvenile	21.84	General Fund	Bus. Type Capital Outlay	1001-0680-57085	N/A
INGRAM LIBRARY SERVICES, LLC	4/9/2025	129481	3/12/2025	63158089	Juvenile	174.77	General Fund	Bus. Type Capital Outlay	1001-0680-57085	N/A
INGRAM LIBRARY SERVICES, LLC	4/9/2025	129482	3/12/2025	63158094	Juvenile	21.73	General Fund	Bus. Type Capital Outlay	1001-0680-57085	N/A
INGRAM LIBRARY SERVICES, LLC	4/9/2025	129482	3/12/2025	63158090	Juvenile	22.41	General Fund	Bus. Type Capital Outlay	1001-0680-57085	N/A
INGRAM LIBRARY SERVICES, LLC	4/9/2025	129482	3/12/2025	63158040	Juvenile	31.58	General Fund	Bus. Type Capital Outlay	1001-0680-57085	N/A
INGRAM LIBRARY SERVICES, LLC	4/9/2025	129482	3/12/2025	63158043	Young Adult	32.32	General Fund	Bus. Type Capital Outlay	1001-0680-57082	N/A
INGRAM LIBRARY SERVICES, LLC	4/9/2025	129482	3/12/2025	63158042	Juvenile	35.07	General Fund	Bus. Type Capital Outlay	1001-0680-57085	N/A
INGRAM LIBRARY SERVICES, LLC	4/9/2025	129482	3/12/2025	63158091	Young Adult	45.39	General Fund	Bus. Type Capital Outlay	1001-0680-57082	N/A
INGRAM LIBRARY SERVICES, LLC	4/9/2025	129482	3/12/2025	63158087	Juvenile	66.24	General Fund	Bus. Type Capital Outlay	1001-0680-57085	N/A
INGRAM LIBRARY SERVICES, LLC	4/9/2025	129482	3/12/2025	63158088	Adult Nonfiction	68.40	General Fund	Bus. Type Capital Outlay	1001-0680-57080	N/A
INGRAM LIBRARY SERVICES, LLC	4/9/2025	129482	3/12/2025	67795850	Juvenile	69.80	General Fund	Bus. Type Capital Outlay	1001-0680-57085	N/A
INGRAM LIBRARY SERVICES, LLC	4/9/2025	129482	3/12/2025	63158044	Adult Fiction	72.77	General Fund	Bus. Type Capital Outlay	1001-0680-57081	N/A
INGRAM LIBRARY SERVICES, LLC	4/9/2025	129482	3/12/2025	63158092	Adult Nonfiction	146.71	General Fund	Bus. Type Capital Outlay	1001-0680-57080	N/A
INGRAM LIBRARY SERVICES, LLC	4/9/2025	129482	3/12/2025	63158099	Adult Fiction	165.27	General Fund	Bus. Type Capital Outlay	1001-0680-57081	N/A
INGRAM LIBRARY SERVICES, LLC	4/9/2025	129482	3/12/2025	63158097	Adult Fiction	214.34	General Fund	Bus. Type Capital Outlay	1001-0680-57081	N/A
INGRAM LIBRARY SERVICES, LLC	4/9/2025	129482	3/12/2025	63158045	Juvenile	10.34	General Fund	Bus. Type Capital Outlay	1001-0680-57085	N/A
INGRAM LIBRARY SERVICES, LLC	4/9/2025	129482	3/12/2025	63158041	Juvenile	11.49	General Fund	Bus. Type Capital Outlay	1001-0680-57085	N/A
INGRAM LIBRARY SERVICES, LLC	4/9/2025	129482	3/12/2025	63158038	Juvenile	12.77	General Fund	Bus. Type Capital Outlay	1001-0680-57085	N/A
INGRAM LIBRARY SERVICES, LLC	4/9/2025	129482	3/12/2025	63158093	Juvenile	14.23	General Fund	Bus. Type Capital Outlay	1001-0680-57085	N/A
INGRAM LIBRARY SERVICES, LLC	4/9/2025	129482	3/12/2025	63158039	Adult Nonfiction	16.68	General Fund	Bus. Type Capital Outlay	1001-0680-57080	N/A
INGRAM LIBRARY SERVICES, LLC	4/9/2025	129481	3/13/2025	67796832	Juvenile	25.33	General Fund	Bus. Type Capital Outlay	1001-0680-57085	N/A
INGRAM LIBRARY SERVICES, LLC	4/9/2025	129481	3/13/2025	67796835	Juvenile	77.51	General Fund	Bus. Type Capital Outlay	1001-0680-57085	N/A
INGRAM LIBRARY SERVICES, LLC	4/9/2025	129481	3/13/2025	67796834	Juvenile	103.32	General Fund	Bus. Type Capital Outlay	1001-0680-57085	N/A
INGRAM LIBRARY SERVICES, LLC	4/9/2025	129481	3/14/2025	63158726	Young Adult	66.80	General Fund	Bus. Type Capital Outlay	1001-0680-57082	N/A
INGRAM LIBRARY SERVICES, LLC	4/9/2025	129482	3/14/2025	63159056	Adult Fiction	26.91	General Fund	Bus. Type Capital Outlay	1001-0680-57081	N/A
INGRAM LIBRARY SERVICES, LLC	4/9/2025	129482	3/14/2025	63159055	Adult Fiction	58.40	General Fund	Bus. Type Capital Outlay	1001-0680-57081	N/A
INGRAM LIBRARY SERVICES, LLC	4/9/2025	129482	3/14/2025	63159052	Juvenile	68.92	General Fund	Bus. Type Capital Outlay	1001-0680-57085	N/A
INGRAM LIBRARY SERVICES, LLC	4/9/2025	129482	3/14/2025	63159048	Juvenile	6.74	General Fund	Bus. Type Capital Outlay	1001-0680-57085	N/A
INGRAM LIBRARY SERVICES, LLC	4/9/2025	129482	3/14/2025	63159054	Juvenile	10.92	General Fund	Bus. Type Capital Outlay	1001-0680-57085	N/A
INGRAM LIBRARY SERVICES, LLC	4/9/2025	129482	3/14/2025	63159051	Adult Nonfiction	13.19	General Fund	Bus. Type Capital Outlay	1001-0680-57080	N/A
INGRAM LIBRARY SERVICES, LLC	4/9/2025	129482	3/14/2025	63159046	Juvenile	13.34	General Fund	Bus. Type Capital Outlay	1001-0680-57085	N/A
INGRAM LIBRARY SERVICES, LLC	4/9/2025	129482	3/14/2025	63159053	Juvenile	14.37	General Fund	Bus. Type Capital Outlay	1001-0680-57085	N/A
INGRAM LIBRARY SERVICES, LLC	4/9/2025	129482	3/14/2025	63159050	Adult Nonfiction	16.19	General Fund	Bus. Type Capital Outlay	1001-0680-57080	N/A
INGRAM LIBRARY SERVICES, LLC	4/9/2025	129482	3/14/2025	63159047	Adult Nonfiction	17.24	General Fund	Bus. Type Capital Outlay	1001-0680-57080	N/A
INGRAM LIBRARY SERVICES, LLC	4/9/2025	129481	3/19/2025	63159722	Adult Fiction	18.40	General Fund	Bus. Type Capital Outlay	1001-0680-57081	N/A
INGRAM LIBRARY SERVICES, LLC	4/9/2025	129481	3/19/2025	63159714	Juvenile	21.84	General Fund	Bus. Type Capital Outlay	1001-0680-57085	N/A
INGRAM LIBRARY SERVICES, LLC	4/9/2025	129481	3/19/2025	63159495	Young Adult	23.56	General Fund	Bus. Type Capital Outlay	1001-0680-57082	N/A
INGRAM LIBRARY SERVICES, LLC	4/9/2025	129481	3/19/2025	63159494	Juvenile	29.78	General Fund	Bus. Type Capital Outlay	1001-0680-57085	N/A
INGRAM LIBRARY SERVICES, LLC	4/9/2025	129481	3/19/2025	63159504	Juvenile	30.84	General Fund	Bus. Type Capital Outlay	1001-0680-57085	N/A
INGRAM LIBRARY SERVICES, LLC	4/9/2025	129481	3/19/2025	63159498	Juvenile	36.82	General Fund	Bus. Type Capital Outlay	1001-0680-57085	N/A
INGRAM LIBRARY SERVICES, LLC	4/9/2025	129481	3/19/2025	63159492	Adult Nonfiction	68.40	General Fund	Bus. Type Capital Outlay	1001-0680-57080	N/A
INGRAM LIBRARY SERVICES, LLC	4/9/2025	129481	3/19/2025	63159491	Juvenile	77.02	General Fund	Bus. Type Capital Outlay	1001-0680-57085	N/A
INGRAM LIBRARY SERVICES, LLC	4/9/2025	129481	3/19/2025	63159497	Adult Nonfiction	81.05	General Fund	Bus. Type Capital Outlay	1001-0680-57080	N/A

Bettendorf Public Library AP Disbursements - 04.09.25

Vendor Name	Check Date	Check #	Invoice Date	Invoice #	Memo	Amount	Fund	Dept	Account #	Project #
INGRAM LIBRARY SERVICES, LLC	4/9/2025	129481	3/19/2025	63159493	Juvenile	87.13	General Fund	Bus. Type Capital Outlay	1001-0680-57085	N/A
INGRAM LIBRARY SERVICES, LLC	4/9/2025	129481	3/19/2025	63159499	Adult Fiction	217.02	General Fund	Bus. Type Capital Outlay	1001-0680-57081	N/A
INGRAM LIBRARY SERVICES, LLC	4/9/2025	129481	3/19/2025	63159502	Adult Fiction	244.43	General Fund	Bus. Type Capital Outlay	1001-0680-57080	N/A
INGRAM LIBRARY SERVICES, LLC	4/9/2025	129481	3/19/2025	63159721	Adult Nonfiction	1,127.80	General Fund	Bus. Type Capital Outlay	1001-0680-57080	N/A
INGRAM LIBRARY SERVICES, LLC	4/9/2025	129481	3/20/2025	63160148	Adult Nonfiction	17.25	General Fund	Bus. Type Capital Outlay	1001-0680-57080	N/A
INGRAM LIBRARY SERVICES, LLC	4/9/2025	129481	3/20/2025	67802337	Adult Nonfiction	70.96	General Fund	Bus. Type Capital Outlay	1001-0680-57080	N/A
INGRAM LIBRARY SERVICES, LLC	4/9/2025	129481	3/21/2025	63160911	Juvenile	17.08	General Fund	Bus. Type Capital Outlay	1001-0680-57085	N/A
INGRAM LIBRARY SERVICES, LLC	4/9/2025	129481	3/21/2025	63160909	Adult Nonfiction	17.25	General Fund	Bus. Type Capital Outlay	1001-0680-57080	N/A
INGRAM LIBRARY SERVICES, LLC	4/9/2025	129481	3/21/2025	63160917	Adult Fiction	30.29	General Fund	Bus. Type Capital Outlay	1001-0680-57081	N/A
INGRAM LIBRARY SERVICES, LLC	4/9/2025	129481	3/21/2025	63160912	Adult Nonfiction	32.23	General Fund	Bus. Type Capital Outlay	1001-0680-57080	N/A
INGRAM LIBRARY SERVICES, LLC	4/9/2025	129481	3/21/2025	63160914	Juvenile	43.62	General Fund	Bus. Type Capital Outlay	1001-0680-57085	N/A
INGRAM LIBRARY SERVICES, LLC	4/9/2025	129481	3/21/2025	63160916	Adult Nonfiction	48.29	General Fund	Bus. Type Capital Outlay	1001-0680-57080	N/A
INGRAM LIBRARY SERVICES, LLC	4/9/2025	129481	3/24/2025	63161142	Juvenile	18.76	General Fund	Bus. Type Capital Outlay	1001-0680-57085	N/A
INGRAM LIBRARY SERVICES, LLC	4/9/2025	129481	3/24/2025	63161146	Adult Fiction	30.39	General Fund	Bus. Type Capital Outlay	1001-0680-57081	N/A
INGRAM LIBRARY SERVICES, LLC	4/9/2025	129481	3/25/2025	67800450	Juvenile	12.88	General Fund	Bus. Type Capital Outlay	1001-0680-57085	N/A
INGRAM LIBRARY SERVICES, LLC	4/9/2025	129481	3/25/2025	63161431	Juvenile	14.98	General Fund	Bus. Type Capital Outlay	1001-0680-57085	N/A
INGRAM LIBRARY SERVICES, LLC	4/9/2025	129481	3/25/2025	67800452	Young Adult	17.96	General Fund	Bus. Type Capital Outlay	1001-0680-57082	N/A
INGRAM LIBRARY SERVICES, LLC	4/9/2025	129481	3/25/2025	63161435	Juvenile	17.98	General Fund	Bus. Type Capital Outlay	1001-0680-57085	N/A
INGRAM LIBRARY SERVICES, LLC	4/9/2025	129481	3/25/2025	63161434	Adult Nonfiction	23.00	General Fund	Bus. Type Capital Outlay	1001-0680-57080	N/A
INGRAM LIBRARY SERVICES, LLC	4/9/2025	129481	3/25/2025	63161430	Adult Nonfiction	37.21	General Fund	Bus. Type Capital Outlay	1001-0680-57080	N/A
INGRAM LIBRARY SERVICES, LLC	4/9/2025	129481	3/25/2025	506933919	Video	37.49	General Fund	Bus. Type Capital Outlay	1001-0680-57076	N/A
INGRAM LIBRARY SERVICES, LLC	4/9/2025	129481	3/25/2025	67800453	Adult Nonfiction	47.23	General Fund	Bus. Type Capital Outlay	1001-0680-57080	N/A
INGRAM LIBRARY SERVICES, LLC	4/9/2025	129481	3/25/2025	67801029	Juvenile	53.93	General Fund	Bus. Type Capital Outlay	1001-0680-57085	N/A
INGRAM LIBRARY SERVICES, LLC	4/9/2025	129481	3/25/2025	67801030	Juvenile	117.18	General Fund	Bus. Type Capital Outlay	1001-0680-57085	N/A
INGRAM LIBRARY SERVICES, LLC	4/9/2025	129481	3/26/2025	63162165	Juvenile	14.37	General Fund	Bus. Type Capital Outlay	1001-0680-57085	N/A
INGRAM LIBRARY SERVICES, LLC	4/9/2025	129481	3/26/2025	63162159	Juvenile	22.41	General Fund	Bus. Type Capital Outlay	1001-0680-57085	N/A
INGRAM LIBRARY SERVICES, LLC	4/9/2025	129481	3/26/2025	63162157	Adult Nonfiction	26.00	General Fund	Bus. Type Capital Outlay	1001-0680-57080	N/A
INGRAM LIBRARY SERVICES, LLC	4/9/2025	129481	3/26/2025	63162158	Juvenile	29.96	General Fund	Bus. Type Capital Outlay	1001-0680-57085	N/A
INGRAM LIBRARY SERVICES, LLC	4/9/2025	129481	3/26/2025	63162168	Young Adult	37.93	General Fund	Bus. Type Capital Outlay	1001-0680-57082	N/A
INGRAM LIBRARY SERVICES, LLC	4/9/2025	129481	3/26/2025	63162174	Juvenile	45.58	General Fund	Bus. Type Capital Outlay	1001-0680-57085	N/A
INGRAM LIBRARY SERVICES, LLC	4/9/2025	129481	3/26/2025	63162163	Adult Nonfiction	89.93	General Fund	Bus. Type Capital Outlay	1001-0680-57080	N/A
INGRAM LIBRARY SERVICES, LLC	4/9/2025	129481	3/26/2025	63162170	Juvenile	103.62	General Fund	Bus. Type Capital Outlay	1001-0680-57085	N/A
INGRAM LIBRARY SERVICES, LLC	4/9/2025	129481	3/26/2025	63162169	Adult Nonfiction	119.36	General Fund	Bus. Type Capital Outlay	1001-0680-57080	N/A
INGRAM LIBRARY SERVICES, LLC	4/9/2025	129481	3/26/2025	63162162	Juvenile	128.07	General Fund	Bus. Type Capital Outlay	1001-0680-57085	N/A
INGRAM LIBRARY SERVICES, LLC	4/9/2025	129481	3/26/2025	63162161	Juvenile	137.71	General Fund	Bus. Type Capital Outlay	1001-0680-57085	N/A
INGRAM LIBRARY SERVICES, LLC	4/9/2025	129481	3/26/2025	63162166	Juvenile	159.47	General Fund	Bus. Type Capital Outlay	1001-0680-57085	N/A
INGRAM LIBRARY SERVICES, LLC	4/9/2025	129481	3/26/2025	63162173	Adult Fiction	237.79	General Fund	Bus. Type Capital Outlay	1001-0680-57081	N/A
INGRAM LIBRARY SERVICES, LLC	4/9/2025	129481	3/26/2025	63162171	Juvenile	463.88	General Fund	Bus. Type Capital Outlay	1001-0680-57085	N/A
INGRAM LIBRARY SERVICES, LLC	4/9/2025	129481	3/27/2025	67801614	Adult Nonfiction	123.20	General Fund	Bus. Type Capital Outlay	1001-0680-57080	N/A
INGRAM LIBRARY SERVICES, LLC	4/9/2025	129481	3/28/2025	63162722	Adult Nonfiction	18.95	General Fund	Bus. Type Capital Outlay	1001-0680-57080	N/A
INGRAM LIBRARY SERVICES, LLC	4/9/2025	129481	3/28/2025	63162720	Adult Nonfiction	21.21	General Fund	Bus. Type Capital Outlay	1001-0680-57080	N/A
INGRAM LIBRARY SERVICES, LLC	4/9/2025	129481	3/28/2025	63162726	Juvenile	29.22	General Fund	Bus. Type Capital Outlay	1001-0680-57085	N/A
INGRAM LIBRARY SERVICES, LLC	4/9/2025	129481	3/28/2025	63162728	Adult Fiction	32.20	General Fund	Bus. Type Capital Outlay	1001-0680-57081	N/A
INGRAM LIBRARY SERVICES, LLC	4/9/2025	129481	3/28/2025	63162725	Adult Fiction	32.20	General Fund	Bus. Type Capital Outlay	1001-0680-57081	N/A

Bettendorf Public Library AP Disbursements - 04.09.25

Vendor Name	Check Date	Check #	Invoice Date	Invoice #	Memo	Amount	Fund	Dept	Account #	Project #
KANOPY	4/9/2025	129483	3/31/2025	446414-PPU	Video	569.00	General Fund	Bus. Type Capital Outlay	1001-0680-57076	N/A
MANUFACTURERS' NEWS, INC.	4/9/2025	129486	2/25/2025	326303-00	Standing Reference Order	198.90	General Fund	Bus. Type Capital Outlay	1001-0680-57083	N/A
MICHIGAN STATE UNIVERSITY	4/9/2025	129487	3/3/2025	11211	Reference	20.00	General Fund	Bus. Type Capital Outlay	1001-0680-57083	N/A
MIDWEST TAPE EXCHANGE	4/9/2025	129488	3/10/2025	506866405	Video	7.49	General Fund	Bus. Type Capital Outlay	1001-0680-57076	N/A
MIDWEST TAPE EXCHANGE	4/9/2025	129488	3/10/2025	506866408	Audio	11.99	General Fund	Bus. Type Capital Outlay	1001-0680-57086	N/A
MIDWEST TAPE EXCHANGE	4/9/2025	129488	3/10/2025	506866407	Audio	14.39	General Fund	Bus. Type Capital Outlay	1001-0680-57086	N/A
MIDWEST TAPE EXCHANGE	4/9/2025	129488	3/10/2025	506866404	Video	16.49	General Fund	Bus. Type Capital Outlay	1001-0680-57076	N/A
MIDWEST TAPE EXCHANGE	4/9/2025	129488	3/10/2025	506866406	Video	170.18	General Fund	Bus. Type Capital Outlay	1001-0680-57076	N/A
MIDWEST TAPE EXCHANGE	4/9/2025	129488	3/17/2025	506895577	Audio	17.99	General Fund	Bus. Type Capital Outlay	1001-0680-57086	N/A
MIDWEST TAPE EXCHANGE	4/9/2025	129488	3/17/2025	506895673	Video	23.99	General Fund	Bus. Type Capital Outlay	1001-0680-57076	N/A
MIDWEST TAPE EXCHANGE	4/9/2025	129488	3/17/2025	506895670	Audio	31.48	General Fund	Bus. Type Capital Outlay	1001-0680-57086	N/A
MIDWEST TAPE EXCHANGE	4/9/2025	129488	3/17/2025	506895578	Video	41.23	General Fund	Bus. Type Capital Outlay	1001-0680-57076	N/A
MIDWEST TAPE EXCHANGE	4/9/2025	129488	3/17/2025	506895579	Video	41.24	General Fund	Bus. Type Capital Outlay	1001-0680-57076	N/A
MIDWEST TAPE EXCHANGE	4/9/2025	129488	3/17/2025	506895672	Video	53.23	General Fund	Bus. Type Capital Outlay	1001-0680-57076	N/A
MIDWEST TAPE EXCHANGE	4/9/2025	129488	3/20/2025	506910729	Video	88.53	General Fund	Bus. Type Capital Outlay	1001-0680-57076	N/A
MIDWEST TAPE EXCHANGE	4/9/2025	129488	3/20/2025	506914660	Video	109.71	General Fund	Bus. Type Capital Outlay	1001-0680-57076	N/A
MIDWEST TAPE EXCHANGE	4/9/2025	129488	3/25/2025	506937591	Audio	14.39	General Fund	Bus. Type Capital Outlay	1001-0680-57086	N/A
MIDWEST TAPE EXCHANGE	4/9/2025	129488	3/25/2025	506937593	Video	26.24	General Fund	Bus. Type Capital Outlay	1001-0680-57076	N/A
MIDWEST TAPE EXCHANGE	4/9/2025	129488	3/25/2025	506937590	Video	54.74	General Fund	Bus. Type Capital Outlay	1001-0680-57076	N/A
OVERDRIVE	4/9/2025	129490	1/1/2025	05530DA24367990	Adult Fiction	35.00	General Fund	Bus. Type Capital Outlay	1001-0680-57081	N/A
OVERDRIVE	4/9/2025	129490	1/1/2025	05530DA24384249	audio	52.49	General Fund	Bus. Type Capital Outlay	1001-0680-57086	N/A
OVERDRIVE	4/9/2025	129490	3/11/2025	05530DA25078482	Adult Fiction	198.87	General Fund	Bus. Type Capital Outlay	1001-0680-57081	N/A
OVERDRIVE	4/9/2025	129490	3/11/2025	05530DA25078482	Audio	213.75	General Fund	Bus. Type Capital Outlay	1001-0680-57086	N/A
OVERDRIVE	4/9/2025	129490	3/17/2025	05530DA25083744	Adult Fiction	75.00	General Fund	Bus. Type Capital Outlay	1001-0680-57081	N/A
OVERDRIVE	4/9/2025	129490	3/17/2025	05530DA25083744	Audio	65.00	General Fund	Bus. Type Capital Outlay	1001-0680-57086	N/A
OVERDRIVE	4/9/2025	129490	3/18/2025	05530CO25084649	Young Adult	27.99	General Fund	Bus. Type Capital Outlay	1001-0680-57082	N/A
OVERDRIVE	4/9/2025	129490	3/18/2025	05530CO25084649	Audio	89.99	General Fund	Bus. Type Capital Outlay	1001-0680-57086	N/A
OVERDRIVE	4/9/2025	129490	3/18/2025	05530DA25085501	Adult Fiction	497.12	General Fund	Bus. Type Capital Outlay	1001-0680-57081	N/A
OVERDRIVE	4/9/2025	129490	3/18/2025	05530DA25085501	Audio	531.35	General Fund	Bus. Type Capital Outlay	1001-0680-57086	N/A
OVERDRIVE	4/9/2025	129490	3/25/2025	05530DA25093433	Adult Fiction	406.11	General Fund	Bus. Type Capital Outlay	1001-0680-57081	N/A
OVERDRIVE	4/9/2025	129490	3/25/2025	05530DA25093433	Audio	250.37	General Fund	Bus. Type Capital Outlay	1001-0680-57086	N/A
PENWORTHY CO.	4/9/2025	129491	3/25/2025	0606780-IN	Juvenile	229.52	General Fund	Bus. Type Capital Outlay	1001-0680-57085	N/A
PLAYAWAY PRODUCTS	4/9/2025	129492	3/11/2025	493215	Audio	834.06	General Fund	Bus. Type Capital Outlay	1001-0680-57086	N/A
PLAYAWAY PRODUCTS	4/9/2025	129492	3/26/2025	494550	Videos	493.97	General Fund	Bus. Type Capital Outlay	1001-0680-57076	N/A
PLAYAWAY PRODUCTS	4/9/2025	129492	3/26/2025	494637	Audio	499.42	General Fund	Bus. Type Capital Outlay	1001-0680-57086	N/A
WOLTERS KLUWER LAW & BUSINESS	4/9/2025	129499	1/14/2025	4806205432	Reference	321.41	General Fund	Bus. Type Capital Outlay	1001-0680-57083	N/A
THE TRUSTEES OF COLUMBIA UNIV	4/9/2025	129495	3/13/2025	8614	Reference	15.00	General Fund	Bus. Type Capital Outlay	1001-0680-57083	N/A
						19,660.72	General Fund Total			
PRISM SALES	4/9/2025	129493	3/14/2025	80800F	Service Plan for 3D printer	1,895.00	Enrich Iowa Funds	Infrastructure Grant	2220-0616-56019	N/A
						1,895.00	Enrich Iowa Funds Total			
HEATHER GIBBS	4/9/2025	129480	2/14/2025	FOL 2e	FOL 2e - Office Chairs	160.49	Library Gift Fund	Library Gift Fund	2260-0606-56006	N/A
VESTIS	4/9/2025	129498	2/19/2025	6150503717	First Aid Cabinets	74.95	Library Gift Fund	Library Gift Fund	2260-0606-56006	N/A
VESTIS	4/9/2025	129498	2/26/2025	6150507357	First Aid Cabinets	74.95	Library Gift Fund	Library Gift Fund	2260-0606-56006	N/A
VESTIS	4/9/2025	129498	3/5/2025	6150510740	First Aid Cabinets	74.95	Library Gift Fund	Library Gift Fund	2260-0606-56006	N/A

Bettendorf Public Library AP Disbursements - 04.09.25

Vendor Name	Check Date	Check #	Invoice Date	Invoice #	Memo	Amount	Fund	Dept	Account #	Project #
VESTIS	4/9/2025	129498	3/12/2025	6150514249	First Aid Cabinets	74.95	Library Gift Fund	Library Gift Fund	2260-0606-56006	N/A
VESTIS	4/9/2025	129498	3/19/2025	6150517759	First Aid Cabinet	74.95	Library Gift Fund	Library Gift Fund	2260-0606-56006	N/A
INGRAM LIBRARY SERVICES, LLC	4/9/2025	129482	3/10/2025	63156755	FOL 3h	205.10	Library Gift Fund	Library Gift Fund	2260-0606-56006	N/A
INGRAM LIBRARY SERVICES, LLC	4/9/2025	129481	3/12/2025	67795849	FOL 3h - DIBs Kits (Book Club Kits)	20.90	Library Gift Fund	Library Gift Fund	2260-0606-56006	N/A
INGRAM LIBRARY SERVICES, LLC	4/9/2025	129482	3/12/2025	63158096	Adopted Author	33.35	Library Gift Fund	Library Gift Fund	2260-0606-56007	N/A
INGRAM LIBRARY SERVICES, LLC	4/9/2025	129481	3/28/2025	63162727	Wessels Memorial	21.84	Library Gift Fund	Library Gift Fund	2260-0606-56006	N/A
LOGO PRO, LLC	4/9/2025	129485	1/1/2025	25627	Library Tote bags	932.51	Library Gift Fund	Library Gift Fund	2260-0606-56006	N/A
MUSSER PUBLIC LIBRARY	4/9/2025	129489	3/22/2025	RAY0322	Reimburse Library	20.00	Library Gift Fund	Library Gift Fund	2260-0606-56006	N/A
OVERDRIVE	4/9/2025	129490	3/31/2025	05530CP25100921	FOL 5f - Mystery Book Discussion	27.50	Library Gift Fund	Library Gift Fund	2260-0606-56006	N/A
RAGGED BLADE	4/9/2025	129494	3/11/2025	FOL 5e	FOL 5e - Brown Bag Lunch Concert	300.00	Library Gift Fund	Library Gift Fund	2260-0606-56006	N/A
KATHERINE JACKSON	4/9/2025	129484	2/14/2025	FOL 1f2	FOL 1f - Teen Book Club	30.46	Library Gift Fund	Library Gift Fund	2260-0606-56006	N/A
KATHERINE JACKSON	4/9/2025	129484	3/28/2025	FOL 1f	FOL 1f - Teen Book Club	11.99	Library Gift Fund	Library Gift Fund	2260-0606-56006	N/A
THOMAS FLETCHER	4/9/2025	129496	3/11/2025	FOL 5e	FOL 5e - Brown Bag Lunch Concert	350.00	Library Gift Fund	Library Gift Fund	2260-0606-56006	N/A
210 FINANCIAL	4/9/2025	129473	3/4/2025	REFUND-162211	Room Rental Refund	240.00	Library Gift Fund	Library Gift Fund	2260-0606-56006	N/A
						2,728.89	Library Gift Fund Total			
BAKER & TAYLOR ENTERTAINMENT	4/9/2025	129475	3/20/2025	NS25030316	CollectionHQ subscription	6,750.00	Information Services	Info.Procc./Support Serv.	6880-0231-55023	N/A
ENVISIONWARE, INC.	4/9/2025	129478	2/1/2025	INV-US-74858	Software Subscriptions	7,760.60	Information Services	Info.Procc./Support Serv.	6880-0231-55023	N/A
						14,510.60	Information Services Total			
						38,795.21	Grand Total			

March Revenues	Amount
41 - Other City Taxes	112,037.43
42 - Licenses And Permits	77,647.90
43 - Use Of Money	43,981.27
44 - Intergovernmental	72,508.81
45 - Charges For Services	1,035,978.72
46 - Special Assessments	115.00
47 - Miscellaneous Revenues	17,057,124.08
Total	<u><u>18,399,393.21</u></u>